

ATV Pathcross 650cc/800cc/1000cc S & L Series

Maintenance Manual

Shandong Odes Industry Co., Ltd.

Foreword

This manual contains such content as introductions on overhaul, maintenance, overhauling program, dismantling, assembling, troubleshooting and service data of ATV1000

This manual will help you know the vehicle better so that you can assure your customers of fast and reliable service.

This manual has been prepared on the basis of the latest specifications at the time of publication. If modifications have been made since then, differences may exist between the content of this manual and the actual vehicle.

Illustrations in this manual are used to show the basic principles of operation and work procedures. They may not represent the actual vehicle exactly in detail.

Manufacturer reserves the right of no prior notice on product improvement or modification. Repair and maintenance shall be carried out according to actual situation of vehicle.

WARNING

Inexperienced mechanics or mechanics without the proper tools and equipment may not be able to properly perform the services described in this manual.

Improper repair may result in injury to the mechanic and may render the vehicle unsafe for the rider.

GROUP INDEX	
GENERAL INFORMATION	1
PERIODIC MAINTENANCE	2
ENGINE	3
COOLING SYSTEM	4
VEHICLE DISMANTLING	5
ELECTRICAL SYSTEM	6
TROUBLESHOOTING	7

1. GENERAL INFORMATION

VEHICLE APPEARANCE	1-1	MARKER INFORMATIVENESS	1-3
PRECAUTIONS	1-4	Engine Running-in Steps	1-5
TECHNICAL SPECIFICATIONS	1-6	TIGHTENING TORQUE	1-10

ATV800 VEHICLE APPEARANCE

Vehicle left-hand view

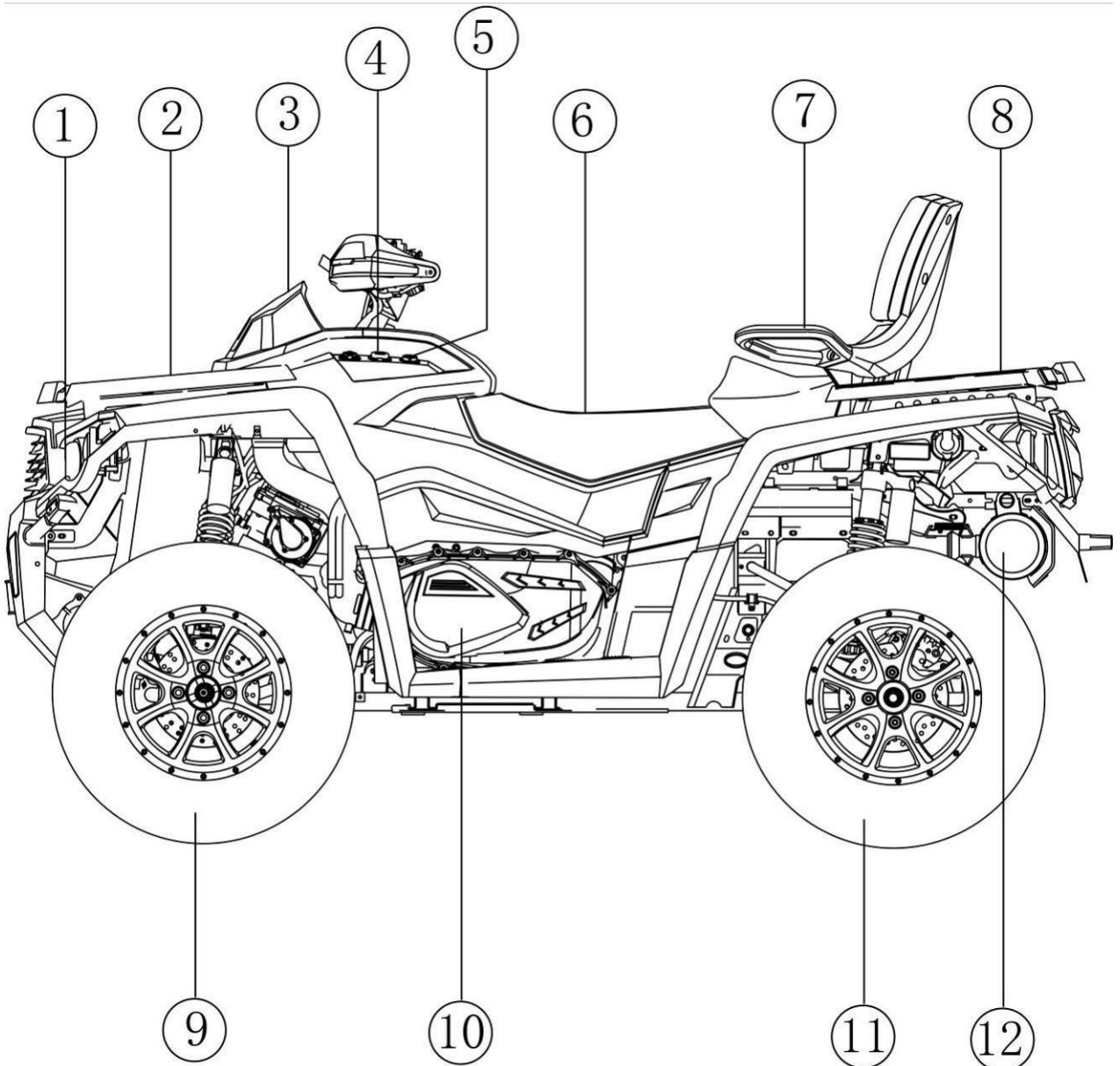

1. Headlight	2. Front rack assembly	3. Instrument assembly	4. Electric lock assembly
5. Spare power	6. Front seat	7. Rear seat	8. Rear rack assembly

9. Front wheel assembly	10. Engine	11. Rear wheel assembly	12. Muffler assembly
-------------------------	------------	-------------------------	----------------------

Vehicle right-hand view

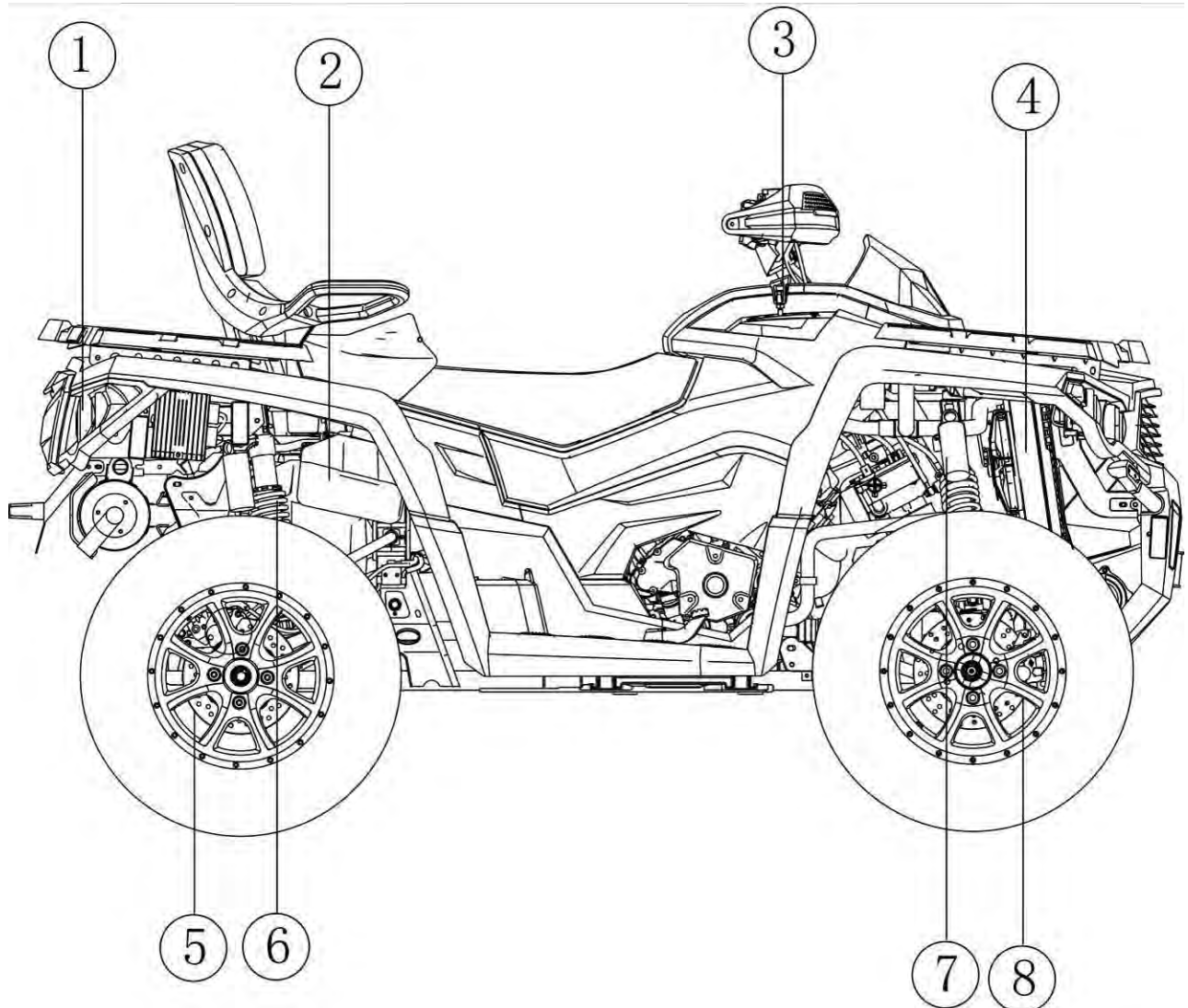

1. Rear light	2. Fuel tank assembly	3. Gear shifting handle	4. Cooling water tank assembly
5. Rear brake assembly	6. Rear shock absorber assembly	7. Front shock absorber assembly	8. Front brake assembly

MARKER INFORMATIVENESS

Numbers of frame (or VIN code), engine and transmission case are major information numbers of a motorcycle. When ordering components or authorizing special services, these numbers are able to assist distributors to serve you better.

Motorcycle mark information is shown as follows:

Figure 1.1.1.

The rack number (or VIN code) is printed on the right main pipe.

Figure 1.1.1

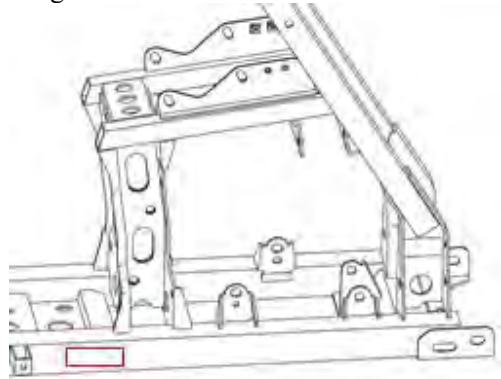

Figure 1.1.2.

Serial number of engine is stamped on the left side of crank case.

Figure 1.1.2

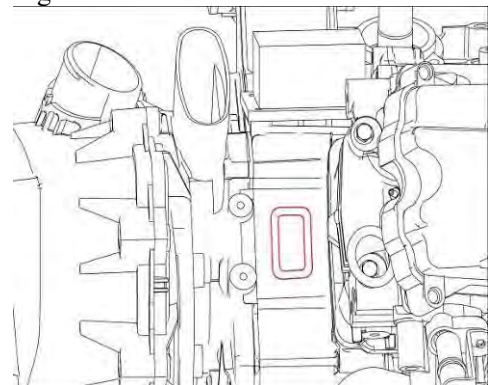

Figure 1.1.3

Serial number of transmission case is stamped at the rear of right gear shift rocker arm.

Figure 1.1.3

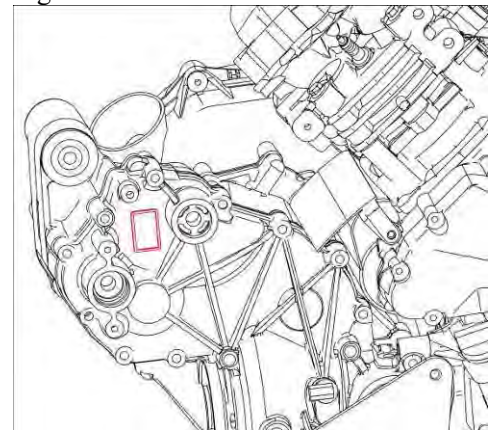
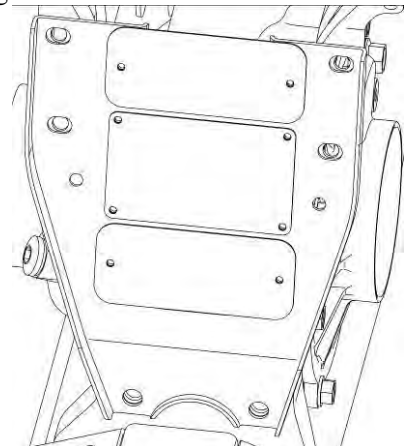

Figure 1.1.4

A metal nameplate shall be installed on the mounting plate of the rear reducer to indicate the main technical parameters, manufacturer and delivery date of the vehicle.

Figure 1.1.4



PRECAUTIONS

1. Do not make engine under operation at a closed place or place with poor ventilation for a long time.
2. If engine stops operation, please do not touch it or silencer to avoid burning.
3. Due to high corrosiveness, battery fluid (dilute sulphuric acid)) may cause burns to skin and eyes. In case of splashing it to skin, please clean it with water and see the doctor immediately. In case of splashing it to clothes, please wash it with water immediately. Keep battery fluid far away from Children.
4. Cooling liquid is toxic. Do not drink it or splash it to skin, eyes and clothes. once splashing it to skin, please wash it with a lot of soapy water. In case of splashing it to eyes, please wash eyes immediately and see the doctor. In case of drinking cooling liquid, resulting in vomit, please see the doctor. Keep cooling liquid far away from children.
5. Wear proper working suit, boots and hat. If necessary, please wear long-sleeve working suit and gloves for operation.
6. Gasoline is highly inflammable. No smoking or firing. At the same time, fire sparks shall be avoided. Vaporized gasoline is explosive as well. Operation shall be carried out at places with good ventilation.
7. Battery may produce explosive hydrogen in charging. Please ensure charging at places with good ventilation.
8. Use legal parts, lubricating oil and lubricating grease.
9. Before overhauling, please clean soil and dust.
10. Keep accessories of each part well for correct assembly.
11. Replace dismantled gasket, O-shaped ring, piston pin retainer and cotter pin.
12. Retainer of rubber ring may be deformed after dismantling. So, please do not use loose and soft retainer.
13. Please wash and dry dismantled parts. Use lubricant on the surface of moving parts. For correct installation, please measure data well in dismantling process.
14. If do not know length of screw, please install screws one by one to ensure their corresponding depth.
15. Pre-tighten bolts and nuts and then tighten them with designated torque from the big to the small and from the inside to the outside.
16. Check whether rubber parts are aged. If necessary, replace them. Keep rubber parts far away from grease.
17. If necessary, special tools can be used.
18. Rotate inside and outside races of bearing to ensure flexibility of balls.
 - a) If axial or radial resistance is too large, please replace it. If there is concave-convex on the surface, please use oil for washing. If no effect is achieved with washing, please replace it.
 - b) If bearing cannot be clamped tightly in pressing into machine or axle, please replace bearing.
19. Please install a side dust proof bearing at correct direction. In installation of open or double-face dust proof bearing, pay attention to that marks of manufacturer shall be outward.
20. In cleaning and drying bearing, please keep bearing support still. Before installation, please carry out lubrication with oil or lubricating oil.
21. Please correct install elastic retaining ring. Assembling after opening can ensure installation of snap ring into slot.

22. After assembly, please check whether all parts are of perfect tightening and flexible movement.
23. Brake fluid and coolant may damage shell and plastic and rubber parts. In case of being splashed by them, please use water for washing.
24. In installing pipeline, please insert them to bottom of connecting pipeline. In installing pipe clamp, please install them to groove if there is. As for pipeline or pipe clamp that cannot be tightened, please replace them.
25. Do not mix soil or dust into engine and/or hydraulic braking system.
26. Before installation, please clean gasket and spacer of engine shell. Use oil stone to polish scratch of joint face evenly.
27. Do not twist or bend too much cable. Twisted or damaged cables may cause inflexible operation.
28. In assembling protective caps of parts, insert cap into groove if any.

Engine running-in steps

Though quality material has been used for motorcycle manufacturing and all components are conforming to high quality standard, all components and parts shall subject to running-in process before engine reaching maximum load. The reason behind this is that cooperation of components has not reached the best status after their assembling. This leads to damping force of engine and unnecessary mechanical loss. The ideal cooperation can be reached after operation for some time. In this case, mechanical loss can be minimized, reaching the best status and bringing the output power to maximum value. As a result, engine performance directly relates to initial maintenance. Regulation of running-in process is shown as follows:

- Please follow the restriction requirements for engine speed in the running-in period below:

The first 150km	Below 5000 rpm
Till 800km	Below 5500 rpm
Till 1600km	Below 6500 rpm
Above 1600km	Below 8500 rpm

- **Do not fully open the accelerator before the reading of the odometer reaching 1000km. Attention: the speed shall not exceed 6500 rpm no matter what in running-in period.**
- **During the running-in period, the engine shall not work at the same speed with the same gear position for a long time. Try to shift gear position and speed to facility running-in of components.**
- **After 1000km of operation, transmission and crank cases shall be cleaned thoroughly.**

TECHNICAL SPECIFICATIONS

Item		Parameter	
Dimensions		Long	Short
Overall length		2462mm	2302mm
Overall width		1229mm	1229mm
Overall height		1458mm	1458mm
Wheelbase		1508mm	1348mm
Ground clearance		283mm	283mm
Engine			
Type	650cc	Two-cylinder, 4-stroke,SOHC, water cooling,	
	800cc	Two-cylinder, 4-stroke,SOHC, water cooling,	
	1000cc	Two-cylinder, 4-stroke,SOHC, water cooling,	
Number of valves		8(mechanical adjustment)	
Cylinder diameter	650cc	82mm	
	800cc	91 mm	
	1000cc	91 mm	
Piston stroke	650cc	61.5 mm	
	800cc	61.5 mm	
	1000cc	75mm	
Compression ratio	650cc	10.3: 1	
	800cc	10.3: 1	
	1000cc	10.5: 1	
Displacement	650cc	649cc	
	800cc	800cc	
	1000cc	976cc	
Maximum power	650cc	39.5kw/6300rpm	
	800cc	44Kw/6000rpm	
	1000cc	63.7kw/6500rpm	
Maximum torque	650cc	62N.m/5300rpm	
	800cc	73N.m/5000 rpm	
	1000cc	101N.m/5500rpm	
Idle speed	650cc	1250rpm	
	800cc	1250rpm	
	1000cc	1250rpm	
Lubrication	Type	Wet tank lubrication, oil filters can be changed	
	Oil pressure	0.18-0.3MPa at 1250rpm	
	Type of oil	SAE10W-40 SJ	
	Oil quantity	2200mL	
	Replacement of capacity	1850mL	

Fuel	Type	Unleaded gasoline only 92# or higher	
	Fuel pressure	350 KPa	
	Fuel tank capacity	22L	
Valve clearance	Intake	0.05 to 0.09mm	
	Exhaust	0.10 to 0.15mm	
Spark plug	Type/manufacturer	DCPR8E / NGK	
	Gap	0.7 to 0.9mm	
Transmission type		CVT(Continuously Variable Transmission)	
Continuously variable ratio		0.71 to 3.1	
Drive belt width	Service limit	30.00mm	
Gearbox type		Dual range(H/L) with park, neutral and reverse	
Gearbox oil	Capacity	650cc	420mL(GL-4-90)
		800cc	420mL(GL-4-90)
		1000cc	420mL(GL-4-90)
Gear ratio	H	650cc	2.886
		800cc	2.886
		1000cc	3.36
	L	650cc	5.292
		800cc	5.292
		1000cc	5.84
	R	650cc	5.087
		800cc	5.087
		1000cc	7.15
Capacity of cooling liquid	Type	Ethyl glycol/water mix(-35°C)	
	Maximum load	3700ml	
	Capacity of water tank	500ml	
Cooling liquid temperature thermostat	Valve opening	65°C	
	Fan opening	88°C	
Tire			
Type		Tubeless	
Pressure		97 to 110KPa	
Size Front		AT26×9–14(Rim 12×7)	
Size Rear		AT26×11–14(Rim 12×9)	
Brake			
System		Front and rear unified	
Type Front		Dual disc brake	
Type Rear		Dual disc brake	
Operation		Foot/hand operation	

Suspension and shock absorber		
Front suspension		Double wishbone
Rear suspension		Trailing arm Independent (TT) with external stabilizer bar
Front shock absorber		Coil spring / oil damper
Front shock absorber travel		128mm
Rear shock absorber		Coil spring / oil damper
Rear shock absorber travel		140mm
Drive train		
Front differential		Shaft driven/single auto-lock differential
Front differential ratio		3.67:1
Rear axle		Shaft driven/single differential
Rear axle ratio		3.67:1
Front differential oil capacity		180mL(GL-4-90)
Rear differential oil capacity		220mL(GL-4-90)
Electrical		
Ignition system		EFI-DELPHI
Battery	Type	Maintenance Free
	Voltage	12V
	capacity	20AH

TIGHTENING TORQUE

Locking devices (e.g.: locking tabs, elastic stop nuts ,self-locking fasteners ,etc.) must be installed or replaced with new ones, where specified. If the efficiency of a locking device is impaired, it must be renewed.

In order to avoid a poor assembling, tighten screws, bolts or nuts in accordance with the following recommended torque value:

Grade	Torque(N·m)					
	M6	M8	M10	M12	M14	M16
4.6	4~5	10~12	20~25	36~45	55~70	90~110
5.6	5~7	12~15	25~32	45~55	70~90	110~140
6.8	7~9	17~23	33~45	58~78	93~124	145~193
8.8	9~12	22~30	45~59	78~104	124~165	193~257
10.9	13~16	30~36	65~78	110~130	180~201	280~330
12.9	16~21	38~51	75~100	131~175	209~278	326~434

CAUTION

Be sure to use the proper tightening torque for the proper strength grade. Always torque screws, bolts and / or nuts in a criss-cross sequence.

As for important tightening torques , please refer to following standards.

Installation location	Specifications (mm)	Torque N.m(kgf.m)
Fastening bolt of engine	M10	70(7.1)
Fastening nut of suspension arm	M10	70(7.1)
Bolt of rear shock absorber	M12	80(8.2)
Bolt of front shock absorber	M10	80(8.2)
Fastening nut of wheel rim	M10	80(8.2)
Nut of wheel hub	M22	300(30.6)
Bolt of rear brake/stop pump (calipers)	M10	80(8.2)
Bolt of brake/stop disc	M8	26(2.7)
Bolt of front brake/stop pump (calipers)	M10	80(8.2)
Lock nut of steering rod	M12	80(8.2)
Lock bolt of steering gearbox	M12	140(14.3)
Bolt of exhaust pipe	M8	30(3.1)
Fastening nut of rear differential	M10	80(8.2)
Fastening nut of front differential	M10	80(8.2)
Bolt of front propeller shaft flange	M8	40(4.1)
Bolt of front propeller shaft flange	M10	80(8.2)
Bolt of rear propeller shaft flange	M10	80(8.2)
Spark plug	M12	20(2.0)
Water temperature sensor	M12	16(1.6)
Oil pressure switch	M10	12(1.2)
Adjusting nut of valve clearance	M6	12(1.2)
Main pulley bolt	M12	100(10.2)
Driven pulley bolt	M10	60(6.1)
Magneto flywheel bolt	M16	150(15.3)

Magneto stator bolt	M6	12.5(1.3)
One way bolt	M8	30(3.1)
Engine oil drain plug	M12	20(2.0)
Gearbox oil drain plug	M12	20(2.0)
Decompression valve plug	M22	20(2.0)
Cylinder head bolt	M10	60(6.1)
Cylinder head bolt	M6	12.5(1.3)
Connecting rod bolt	M8	50(5.1)
Timing chain wheel bolt	M8	30(3.1)
Front output shaft flange bolt	M8	30(3.1)
Rear output shaft flange bolt	M10	60(6.1)

2. PERIODIC MAINTENANCE

MAINTENANCE SCHEDULE	2-1	AIR CLEANER	2-3
VALVE CLEARANCE	2-4	SPARK PLUG	2-8
THROTTLE CABLE PLAY	2-8	ENGINE OIL	2-9
FRONT REDUCER OIL	2-11	REART REDUCER OIL	2-12
STEERING SYSTEM	2-12	BRAKING SYSTEM	2-13
GEAR SHIFT	2-15	COOLING SYSTEM	2-15
WHEELS	2-18	ENGINE COMPRESSION PRESSURE	2-18
ENGINE OIL PRESSURE	2-19	SUSPENSION SYSTEM	2-20

MAINTENANCE SCHEDULE

In order to maintain the best performance and economical performance of vehicles, suggestions on intervals for necessary regular maintenance are listed. Following maintenance is calculated in km, mile and hour based on firstly appeared data.

However, keep in mind that if the vehicle isn't used for a long period of time, the month maintenance intervals should be followed.

Items marked with an asterisk should be performed by a dealer as they require special tools and technical skills.

In case of complicated road conditions, regular maintenance shall be carried for vehicles.

ITEM	ROUTINE	Whichever Comes first ⇒	INITIAL			EVERY		
			month	1	3	6	6	12
			Km (mi)	320 (200)	1,200 (750)	2,400 (1,500)	2,400 (1,500)	4,800 (3,000)
Valves*	<ul style="list-style-type: none"> Check valve clearance. Adjust if necessary. 		○		○	○	○	
Cooling system	<ul style="list-style-type: none"> Check coolant leakage. Repair if necessary. Replace coolant every 24 months. 		○	○	○	○	○	
Spark plug	<ul style="list-style-type: none"> Check condition. Adjust gap and clean. Replacement every 24 months 		○	○	○	○	○	
Air filter elements	<ul style="list-style-type: none"> Clean. Replacement every 24 months 		Every 20-40 hours (More often in wet or dusty areas.)					
Crankcase breather system*	<ul style="list-style-type: none"> Check breather hose for cracks or damage. Replace if necessary. 				○	○	○	
Exhaust system*	<ul style="list-style-type: none"> Check for leakage. Tighten if necessary. Replace gasket(s) if necessary. 				○	○	○	
Fuel line*	<ul style="list-style-type: none"> Check fuel hose for cracks or damage.. Replacement fuel hose every 48 months Replacement fuel filter every 24 months 				○	○	○	
Engine oil	<ul style="list-style-type: none"> Replace (Check oil level every month) . 		○		○	○	○	
Engine oil filter	<ul style="list-style-type: none"> Replace. 		○		○		○	
Differential and gearbox oil	<ul style="list-style-type: none"> Check oil level/oil leakage. Replacement every 24 months. 		○				○	

2. PERIODIC MAINTENANCE

ITEM	ROUTINE	Whichever Comes first ⇒	INITIAL			EVERY		
			month	1	3	6	6	12
			Km (mi)	320 (200)	1,200 (750)	2,400 (1,500)	2,400 (1,500)	4,800 (3,000)
hours	20	75	150	150	300			
Brake*	<ul style="list-style-type: none"> ●Check operation/brake pad wear/fluid leakage. ●Brake fluid needs to be above the lowest position. ●Correct if necessary. Replace pads/disk if worn to the limit. 		O	O	O	O	O	
Accelerator pedal*	<ul style="list-style-type: none"> ●Check operation and free play. 		O	O	O	O	O	
Wheels*	<ul style="list-style-type: none"> ●Check balance/damage/ run out ●Repair if necessary. 		O		O	O	O	
Wheel bearings*	<ul style="list-style-type: none"> ●Check bearing assemblies for looseness or damage.. ●Replace if damaged. 		O		O	O	O	
Front and rear Suspension*	<ul style="list-style-type: none"> ●Check operation and for leakage. ●Correct if necessary. 				O		O	
Steering system*	<ul style="list-style-type: none"> ●Check operation and for looseness/Replace if damage. ●Check toe-in/Adjust if necessary. 		O	O	O	O	O	
Rear knuckle pivots and suspension arms*	<ul style="list-style-type: none"> ●Lubricate with lithium-soap-based grease. 				O	O	O	
Drive shaft universal joint*	<ul style="list-style-type: none"> ●Lubricate with lithium-soap-based grease. 				O	O	O	
Engine mount*	<ul style="list-style-type: none"> ●Check for cracks or damage. ●Correct bolt tightness. 				O	O	O	
Front and rear axle boots*	<ul style="list-style-type: none"> ●Check operation. ●Replace if damage. 		O				O	
Stabilizer bushings*	<ul style="list-style-type: none"> ●Check for cracks or damage. 				O	O	O	
Fittings and fasteners*	<ul style="list-style-type: none"> ●Check all chassis fittings and fasteners. ●Correct if necessary. 		O	O	O	O	O	
Battery	<ul style="list-style-type: none"> ●End connection 		O		O	O	O	
Lamp and steering indication	<ul style="list-style-type: none"> ●Operation 		O	O	O	O	O	

AIR CLEANER

In case of driving in dusty environment, air filter shall be cleaned regularly. It is of great possibility to accelerate wear to engine if there is not filtering element or worn filtering element is used. So, please keep air filter under good conditions all the time. If vehicle is used in dusty area, inspect more frequently than specified in MAINTENANCE SCHEDULE.

If the air cleaner is clogged with dust, intake resistance will be increased, with a resultant decrease in power output and an increase in fuel consumption. never remove or modify any component in the air filter housing. The engine management system is calibrated to operate specifically with these components. Otherwise, engine performance degradation or damage can occur. Check and clean the air cleaner element in the following manner:

Remove rear seat ①, front seat ② and lower cover plate ③.

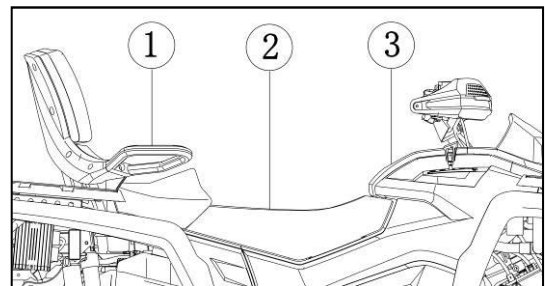

Separating air filter buckle, pull out filter element.

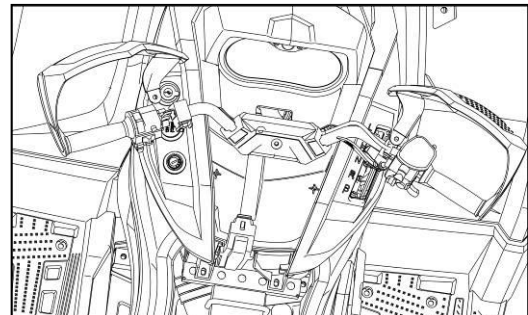

Blow low pressure compressed air on filter element to clean it.

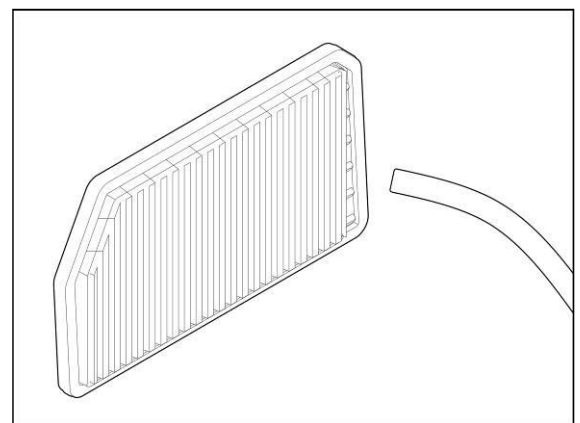

Properly reinstall removed parts in the reverse order of their removal. pay attention to the seal gasket of air filter housing is not skew.

CAUTION

- 1.If liquid /deposits are found, squeeze and dry the foam filter. Replace filter element if damaged.
- 2.Do not start engine if liquid or deposit are found. If there is oil in the air filter housing, check engine oil level. Oil level may be too high.
- 3.Inspect the air cleaner element for tears, a torn element must be replaced.

VALVE CLEARANCE

Excessive valve clearance results in valve noise and insufficient valve clearance results in valve damage and reduced power.

Check the intake and exhaust valve clearances at the distances indicated above and adjust the valve clearances to specification, if necessary.

Valve clearance is to be checked when the engine is cold. The intake and exhaust valves must be checked and adjusted when the piston is at TOP-DEAD –CENTER (TDC) on the compression stroke.

Remove left and right seats, gear shift handle and engine shield.

Remove relevant accessories around an engine, with relevant contents referring to Chapter 5 Vehicle Dismantling

Remove spark plug cable and spark plug of both cylinders

Remove the valve cover of both cylinders

1. Distance screws
2. Valve cover

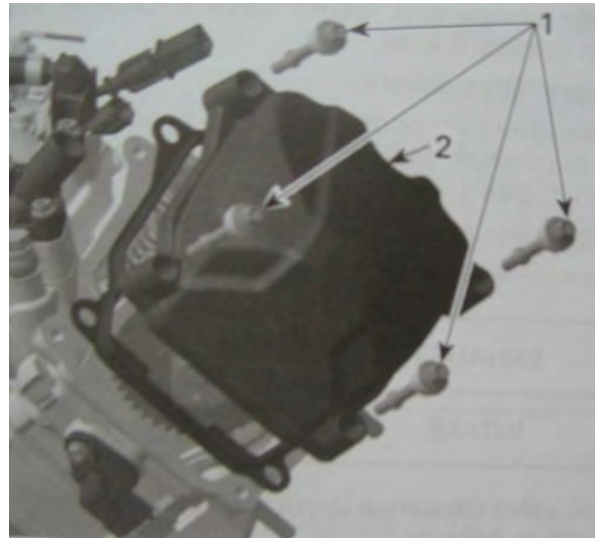

Remove the plug screw and O-ring of magneto cover.

Remove the crankshaft position sensor.

1. Crankshaft position sensor
2. Screw



Valve clearance of cylinder 2

Use a 14 mm Allen key to turn crankshaft until piston 2, rear is at TDC ignition.



When rear piston is at TDC ignition, marks on magneto flywheel “2” and on the magneto cover are aligned.

1. Mark “2” on magneto flywheel
2. Notch on magneto cover
3. Crankshaft position sensor location

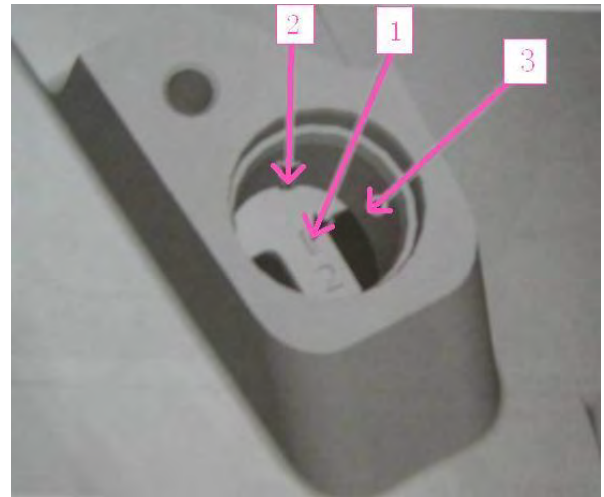

At TDC ignition, the printed marks on the camshaft timing gear have to be parallel to cylinder head base. If not, use Allen key to turn crankshaft 360°

1. Printed marks on camshaft timing gear
2. Cylinder head base

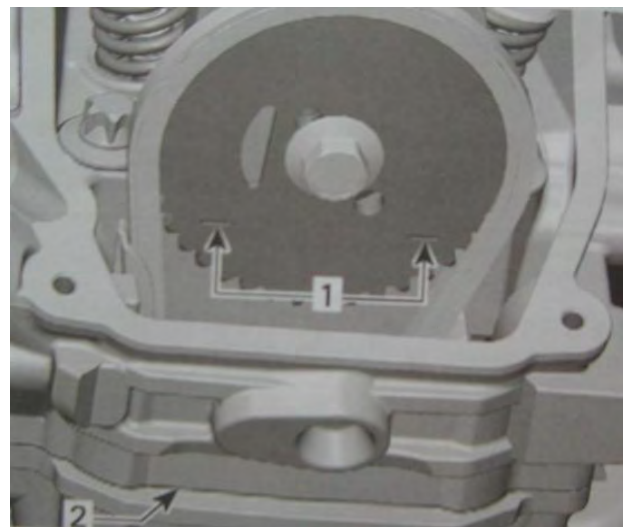

Insert the feeler gauge between the valve stem end and adjusting screw on the rocker arm to check the clearance.

If the valve clearance is out of specification, adjust valves as follows.

Valve clearance	
Intake	0.05 to 0.09mm
Exhaust	0.10 to 0.15mm

Use mean valve of exhaust/intake to ensure a proper valve adjustment.

Hold the adjustment screw at the proper position and torque the locking nut.

Repeat the procedure for each valve.

1. Adjustment screw
2. Adjustment nut
3. Feeler gauge

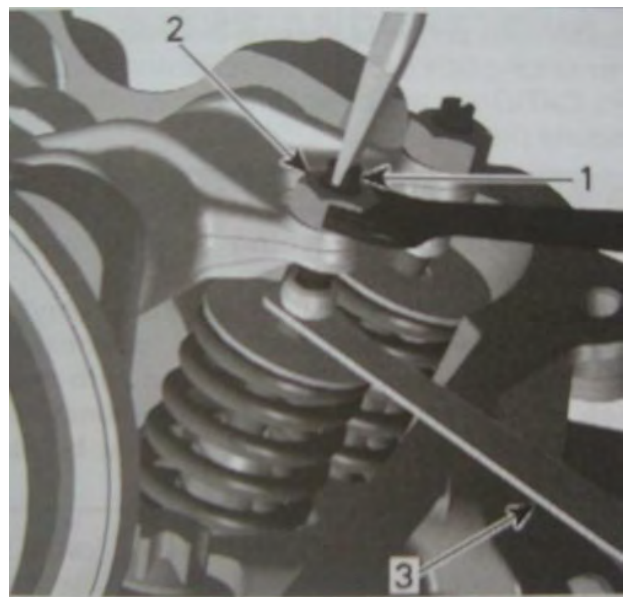

CAUTION

Securely tighten the locknut after completing adjustment.

Valve clearance adjuster locknut:12N.m

Valve clearance of cylinder 1

Using a 14 mm Allen key, turn crankshaft 280 °counterclockwise.

1. Allen key 14mm
2. Turn crankshaft 280°counterclockwise

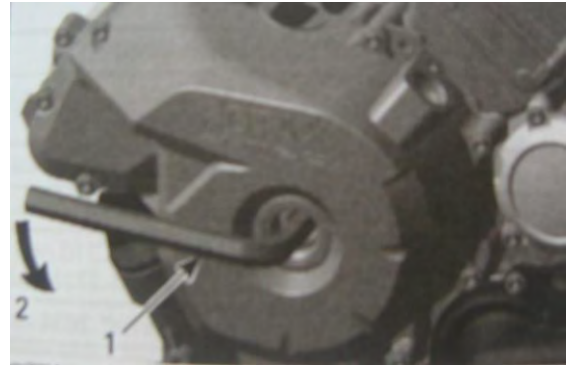

Until marks on magneto flywheel “1” and magneto cover are aligned.

1. Mark “1” on magneto flywheel
2. Notch on magneto cover
3. Location of crankshaft position sensor

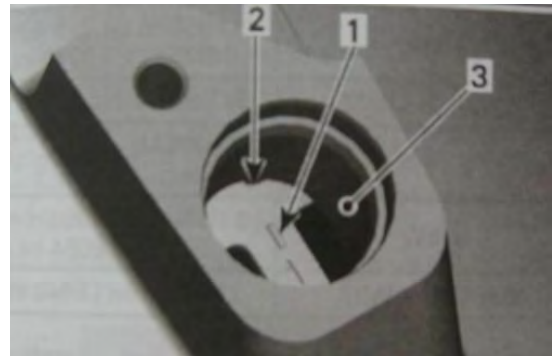

At TDC ignition, the printed marks on the camshaft timing gear have to be parallel to cylinder head base as per following illustration.

TYPICAL

1. Printed marks on camshaft timing gear
2. Cylinder head base

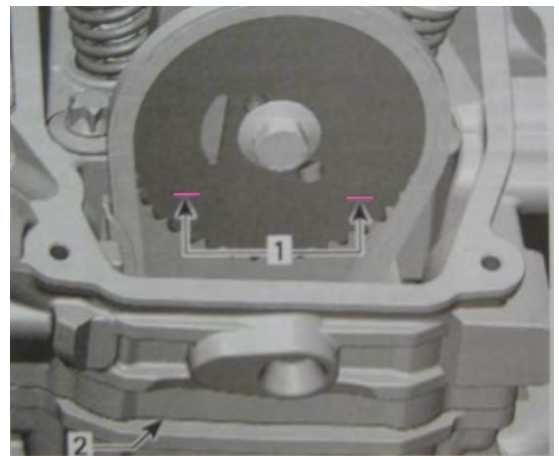

Insert the feeler gauge between the valve stem end and adjusting screw on the rocker arm to check the clearance.

If the valve clearance is out of specification, adjust valves as follows.

Valve clearance	
Intake	0.05 to 0.09mm
Exhaust	0.10 to 0.15mm

Use mean valve of exhaust/intake to ensure a proper valve adjustment.

Hold the adjustment screw at the proper position and torque the locking nut.

Repeat the procedure for each valve.

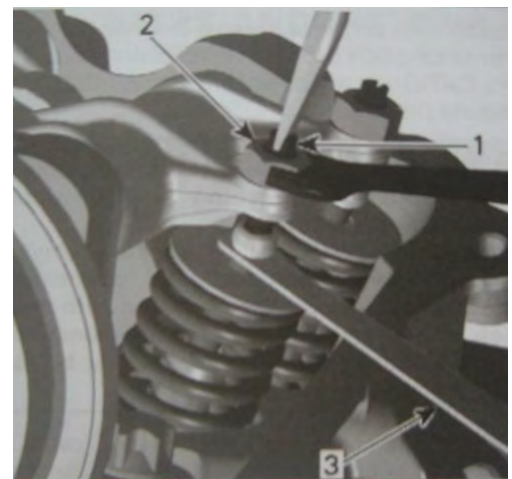

4. Adjustment screw
5. Adjustment nut
6. Feeler gauge

Valve clearance adjuster locknut:12N.m

CAUTION

Securely tighten the locknut after completing adjustment.

Install the valve cover of both cylinders, spark plug cable and spark plug of both cylinders, the plug screw and O-ring of magneto cover and the crankshaft position sensor.

SPARK PLUG

In case of serious wear or burn to electrode or burn to insulator by spark plug or damage to thread etc, please replace it with new spark plug

In case of carbon deposit, please use proper tools for cleaning.

Spark plug gap

Use clearance gauge to measure clearance of spark plug.

In case of exceeding designated range, then adjust the gap.

Spark plug gap: 0.7-0.9mm

Spark plug heat range

Check the spark plug heat range by observing the electrode color. If the electrode of the spark plug is appearing wet or dark color, replace the spark plug with a hotter type one. If it is white or appearing glazed, replace the spark plug with a colder type one.

Standard type: DCPR8E / NGK

Colder type: DCPR9E / NGK

Hotter type: DCPR7E / NGK

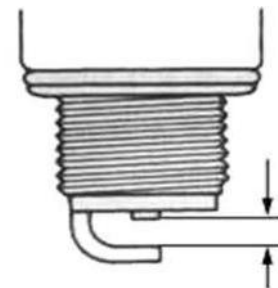

CAUTION

In order to avoiding damaging cylinder cap thread, firstly use hands to tighten spark plug and then use spark plug wrench to tighten cylinder cap with designated torque.

THROTTLE CABLE PLAY

Before starting the engine, check the throttle handle to ensure the correct operation, and ensure that the throttle handle can be completely restored to the idle position without the external force.

Check the free play and adjust, if needed, press the accelerator to ensure that the movement of the smooth and non sticky buckle back when the check throttle handle correctly. It must run smoothly, fully spring back to the free position

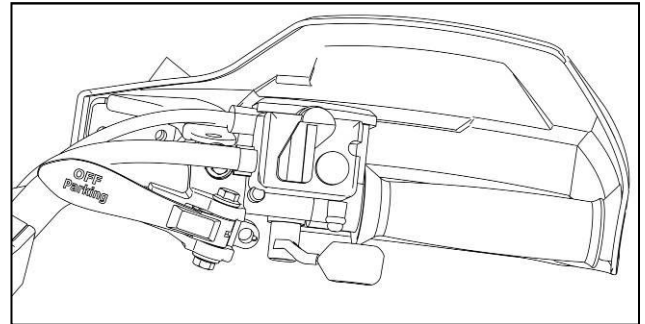

From the gate line (support), turn the regulator, regulate the solar term door handle free play.

After adjustment, tighten nut.

If free play after adjustment cannot reach designated requirement or there is viscosity for throttle valve, replace it with new throttle cable.

ENGINE OIL

Oil level verification

Strictly follow this procedure, otherwise wrong oil level may be indicated.

1. Ensure vehicle is on a level surface.
2. Start engine and let idle for a few minutes.
3. Stop engine. Wait a few minutes to allow oil to flow down to crankcase then check oil level.
4. Remove dipstick and wipe clean stem.
5. Fully screw in dipstick to check oil level.
6. Remove dipstick and read oil level. Oil level must be between minimum(2) and maximum(1) marks on dipstick.
7. There is a capacity of 300 ml between the two marks. Refill oil as necessary. Do not overfill.
8. Reinstall dipstick.

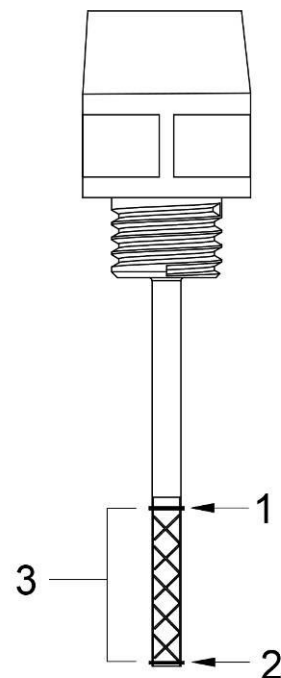

Replace engine oil

Prior to change the oil, ensure vehicle is on a level surface. Oil and oil filter must be replaced at the same time. Oil change and oil filter replacement should be done with a warm engine.

WARNING

The engine oil can be very hot. Wait until engine oil is warm.

CAUTION

Dispose oil and filter as per your local environmental regulations.

1. Ensure vehicle is on a level surface.
2. Start engine and let idle for a few minutes.
3. Stop engine. Wait a few minutes to allow oil to flow down to crankcase then check oil level.
4. Remove the right foot pedal

5. Remove dipstick.
6. Raise the vehicle, support it securely. Place a drain pan under the engine drain plug area.
7. Clean the drain plug area.
8. Unscrew drain plug then remove dipstick.
 - 1) Drain plug
 - 2) Gasket ring

9. Allow oil to drain completely from crankcase.
10. Clean the magnetic drain plug from metal shavings and residue.
11. Install a new gasket ring on drain plug. Torque drain plug to 20 N.m.

12. Remove oil filter screws, oil filter cover and oil filter.
 - 1) Oil filter screw
 - 2) Oil filter cover
 - 3) ring
 - 4) Oil filter
13. Check and clean the oil filter inlet area for dirt and other contaminations.
14. The installation is the reverse of the removal procedure. Pay attention to install a new gasket on oil filter cover.
15. Refill engine with a SAE 10W-40 API SJ classification engine oil, Oil change capacity with filter 1850mL.
16. Check the oil level with the dipstick. Refer to OIL LEVEL VERIFICATION above.

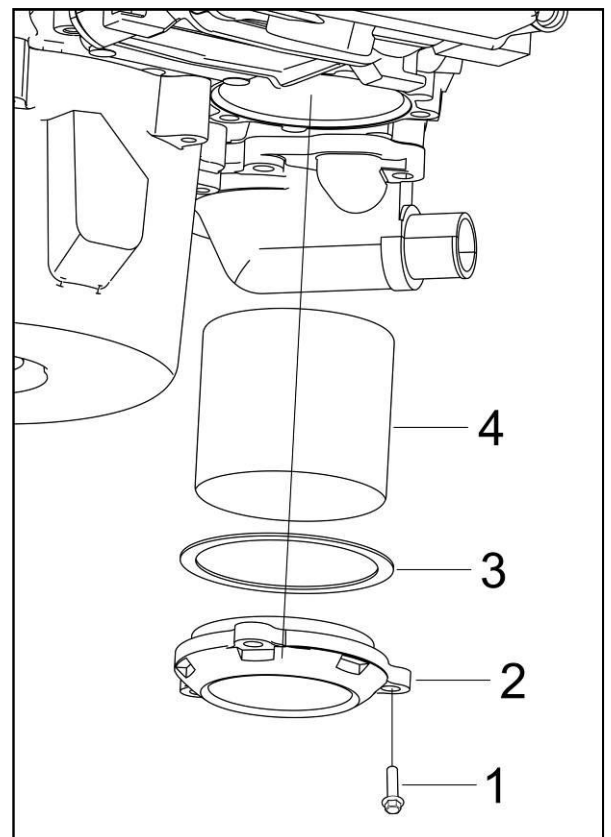

17. Run engine to ensure oil filter and drain plug areas are not leaking.

CAUTION

In order to expand service life of vehicle, please use grade SJ standard engine oil conforming to API with its viscosity indication being SAE10W/40. If viscosity of engine does not reach SAE 10W/40, make corresponding selection according to drawing

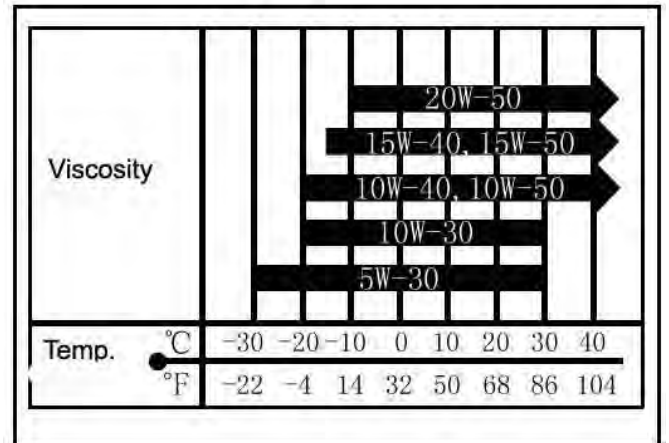
**Replace gearbox oil**

Prior to change the gearbox oil, ensure vehicle is on a level surface, should be done with a warm engine.

1. Ensure vehicle is on a level surface.
2. Drive vehicle for a few minutes.
3. Stop engine and wait a few minutes.
4. Remove engine shield
5. Remove the oil level check plug.
6. Place an oil pan under the gearbox case, and then drain oil completely by removing the drain plug.
7. Tighten the drain plug to 20 N.m.
8. Pour the specified oil(GL-4-90) about 420mL by syringe through the oil level check plug hole until the oil over flows.
9. Tighten the oil level check plug to 20 N.m.

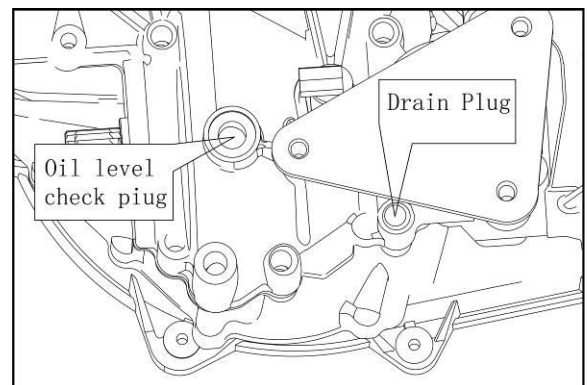
**FRONT DIFFERENTIAL OIL**

To change the front differential oil, locate the vehicle on a level position and carry out the following steps.

Clean the oil level check plug area and remove the oil level check plug.

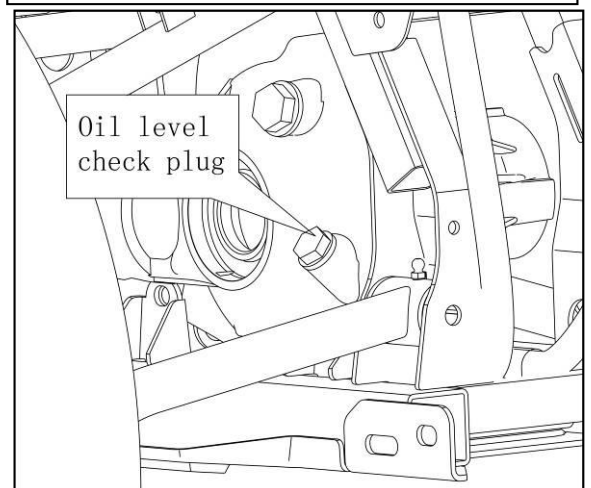

Clean the drain plug area.

Place an oil pan under the front reducer case, and then drain oil completely by removing the drain plug. █

Tighten the drain plug to 20 N.m.

Pour the specified oil(GL-4-90) about 180mL by syringe through the oil level check plug hole until the oil over flows.

Tighten the oil level check plug to 20 N.m.

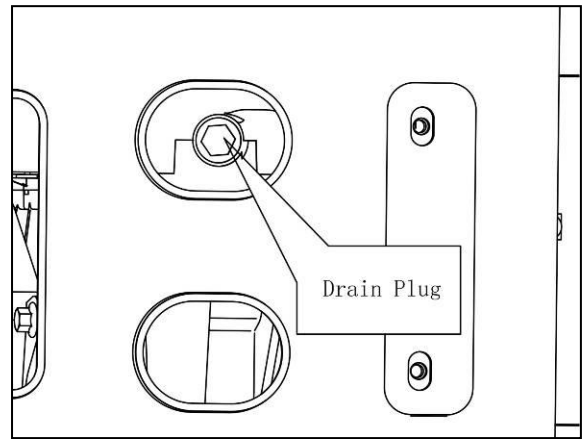

REAR DIFFERENTIAL OIL

To change the rear differential oil, locate the vehicle on a level position and carry out the following steps.

Clean the oil level check plug area and remove the oil level check plug.

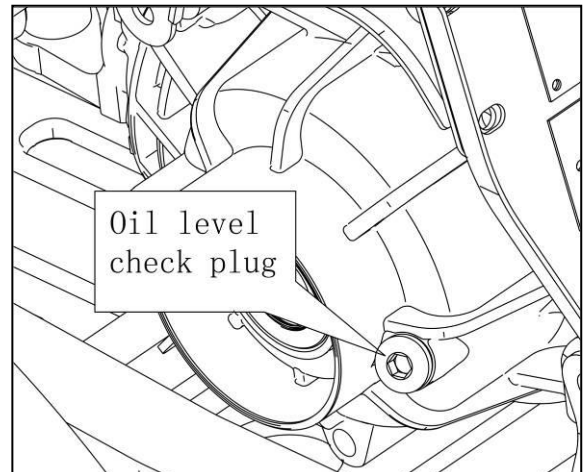

Clean the drain plug area.

Place an oil pan under the front reducer case, and then drain oil completely by removing the drain plug.

Tighten the drain plug to 20 N.m.

Pour the specified oil(GL-4-90) about 220mL by syringe through the oil level check plug hole until the oil over flows.

Tighten the oil level check plug to 20 N.m.

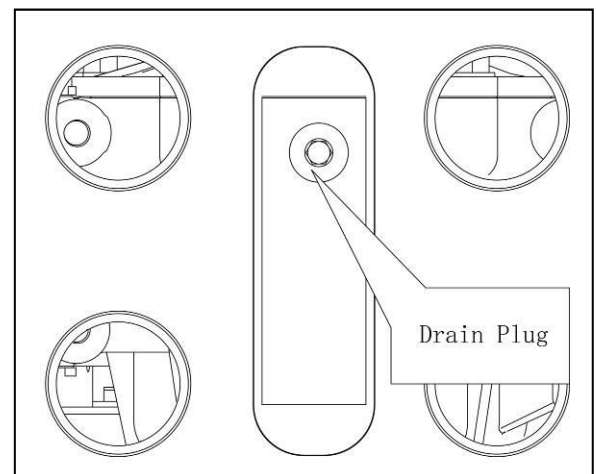

STEERING SYSTEM

Keep handlebar in horizontal status on flat ground and check whether the handlebar is loose from four directions (top, bottom, left and right); tighten nut or dismantle steering column for further checking, if any.

Park vehicle on flat ground and rotate handlebar leftwards and rightwards to check whether it is able to be rotated flexibly. If any stuck, check whether it is caused by installation of main wire group or other wiring; if not, please check the bottom of steering bar to check whether steering column bearing is damaged.

Park vehicle on flat ground, make sure the tire pressure for right and left tires is same and set to the proper specification, set the front wheels in the straight position, then place a load of 75kg on the seat.

Measure the distance A and B of the front wheels and calculate the difference.

Toe-in.: $B - A = 5\text{mm}$

A: front of front wheel

B: rear of front wheel

Out of range of toe-in: → Adjust nut of tie rod

CAUTION

After adjusting toe-in, first rotate steering wheel from center position to the left and right completely, to ensure that it is the same corner, then slowly run vehicle to see whether its direction can be controlled.

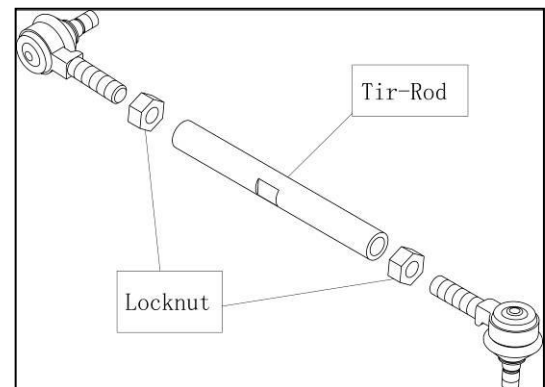
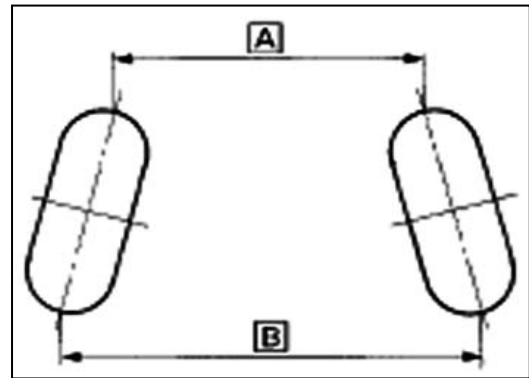

BRAKING SYSTEM

Check to see if any brake fluid is leaking out of the pipe joints or the brake fluid reservoir. Apply the brakes firmly for one minute. If there is any leakage, have the vehicle inspected by an authorized dealer.

Test the brakes at slow speed after starting out to make sure they are working properly.

If the brakes do not provide proper braking performance, inspect the brake system.

If needed, have the vehicle inspected by an authorized dealer.

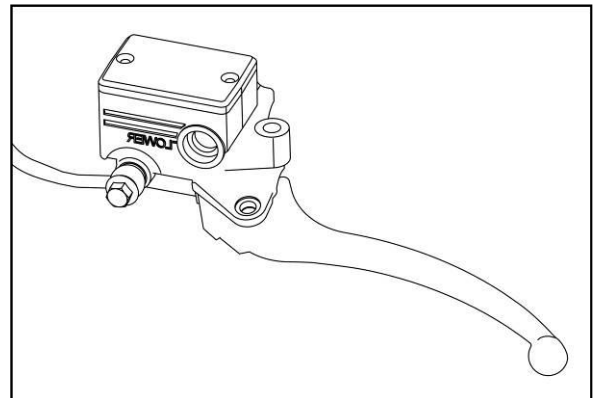

Brake fluid level

Check brake fluid level by observing upper pump of front brake and upper and lower limit line of rear brake fluid.

When brake fluid level is lower than lower limit, supplement brake fluid DOT4 in time.

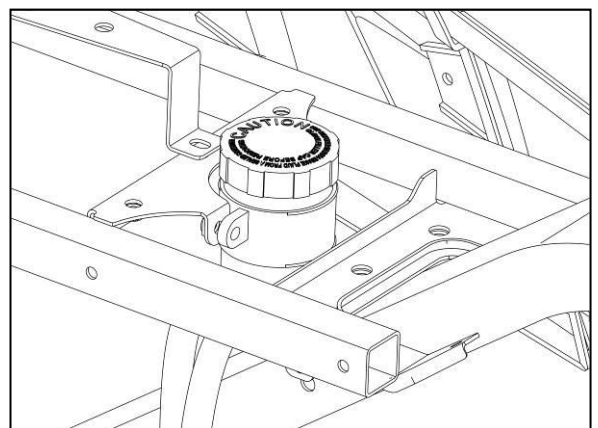

Brake pedal adjustment

The brake pedal stroke is 30~40mm. If less than equal 30mm, it will be a hidden dangers, must adjust the brake pin connecting the brake pedal.

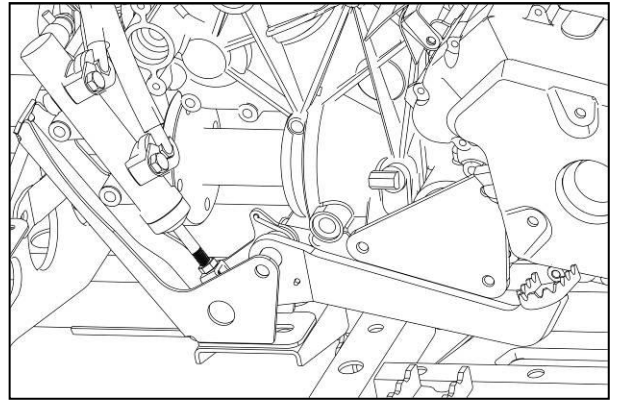

GEAR SHIFT

Check the shift lever as to change gearshift from P to R N H L and reverse smoothly. Also the meter display is correct.

The shift lever should be vertical when the gear is in neutral. If not, adjust the shift cable and then tighten the nuts of the shift cable.

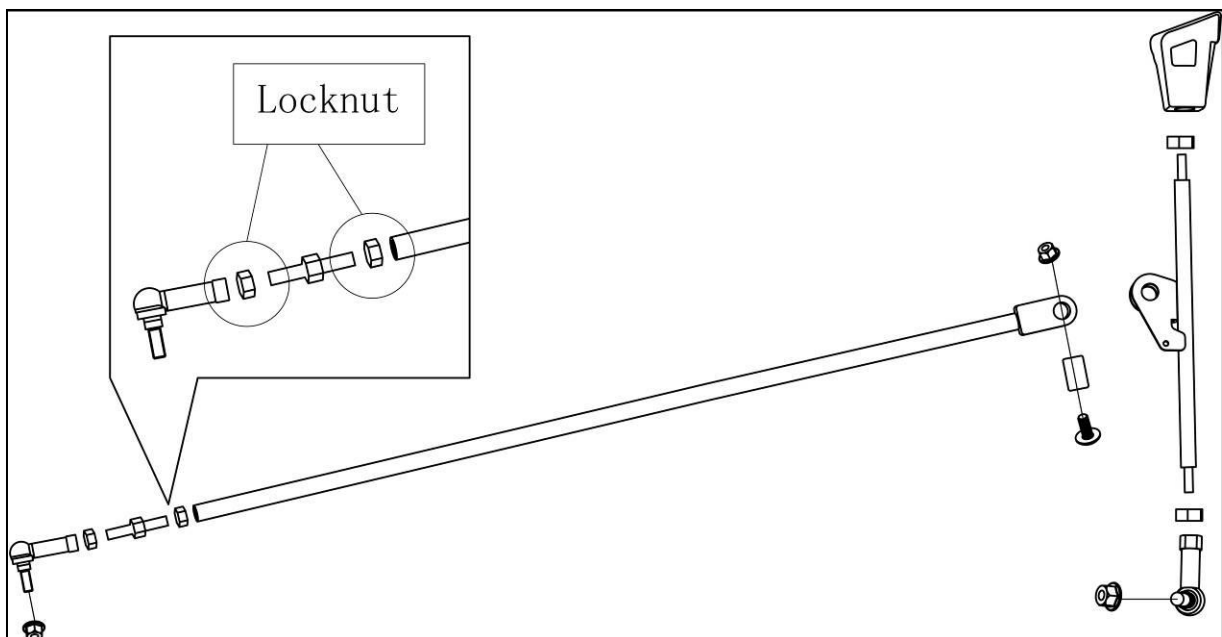
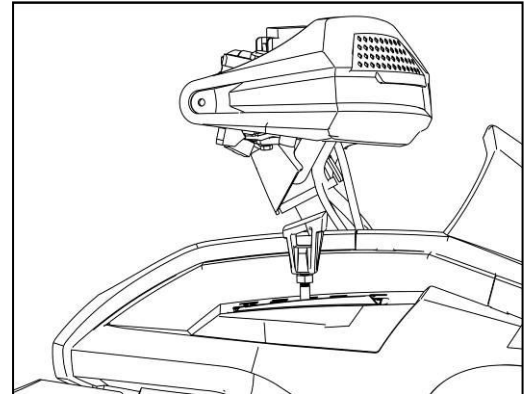

COOLING SYSTEM

To prevent rust formation or freezing condition, always replenish the system with the premixed coolant or with 50% antifreeze and 50% water. Do not use tap water, straight antifreeze or straight water in the system. Tap water contains minerals and impurities which build up in the system. During cold weather, straight water causes the system to freeze while straight antifreeze thickens and does not have the same efficiency. Always use ethylene glycol antifreeze containing corrosion inhibitors specifically recommended for aluminum engines.

Cooling liquid may be reduced by natural evaporation. Regularly check horizontal position of cooling liquid

Coolant level verification

Park vehicle at flat ground and check horizontal line of cooling liquid.

Remove the meter cover.

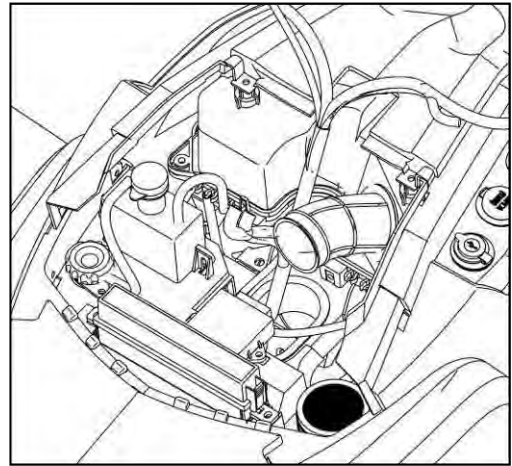

Check the level of cooling water in fluid reservoir (auxiliary radiator) is between upper and lower critical levels.

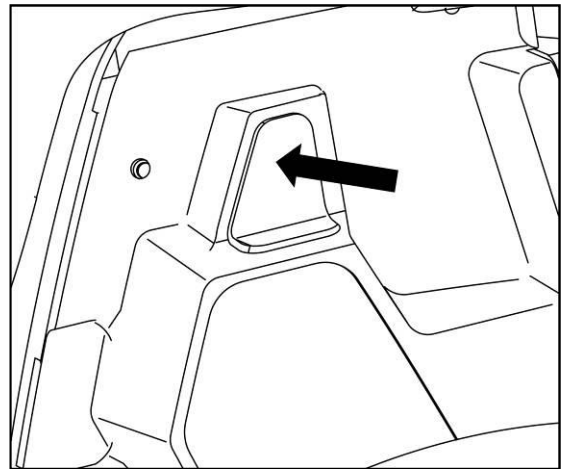
**WARNING**

To avoid potential burns, do not remove the radiator cap or loosen the cooling drain plug if the engine is hot. Never drain or refill cooling system when engine is hot.

Coolant replacement

Park vehicle at flat ground and check horizontal line of cooling liquid.

Remove the upper cover of engine hood. Remove auxiliary tank cover ① and radiator cover ②

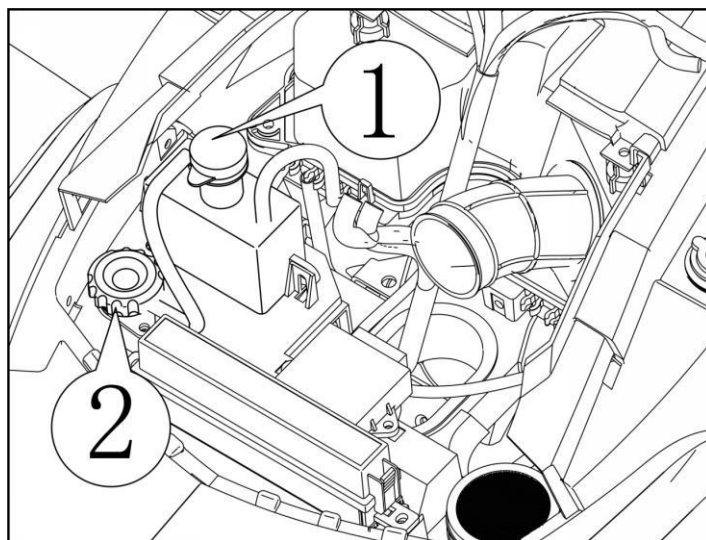

Partially unscrew coolant drain plug located below water pump housing.

When coolant is drained completely, remove cooling drain plug completely and install a new gasket ring.

Screw the coolant drain bolt and torque it to 10 N.m.

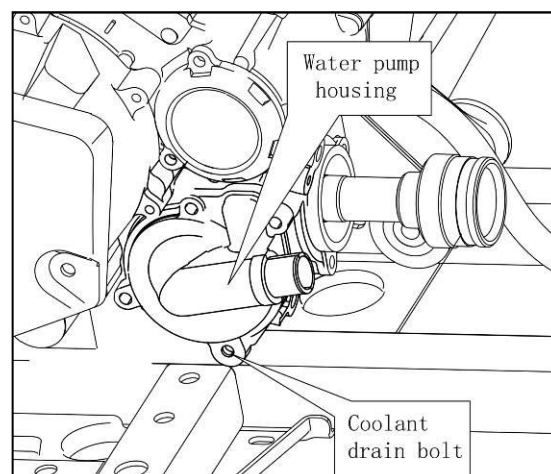

Unscrew bleed screws on top of thermostat housing. Both cylinders must be bled.

Fill up the radiator with coolant, when the coolant comes out by the thermostat housing hole, install the bleed screws with its gasket ring and torque to 10 N.m.

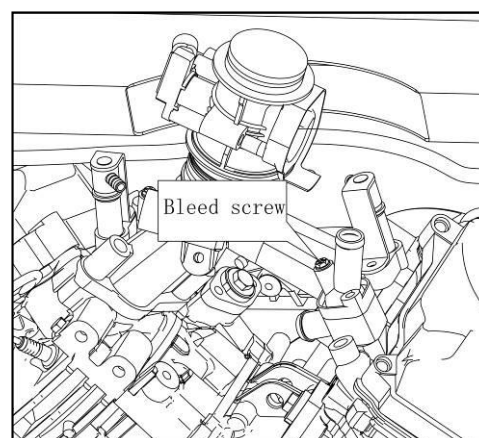

Refill coolant tank up to upper level mark. Install the coolant tank cap^① and the radiator cap^②.

Run engine until radiator fan opens then stop engine.

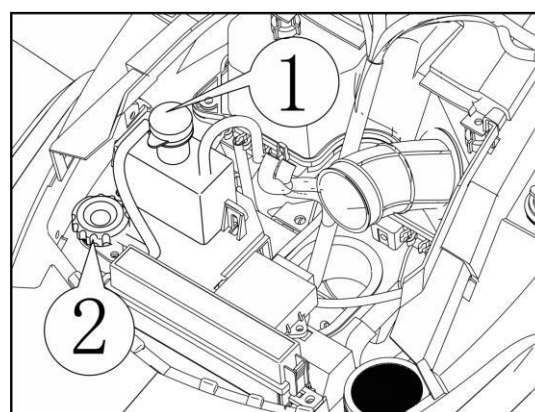

When engine has completely cooled down, recheck coolant level in radiator and coolant tank, Top up if necessary

WHEELS

Lift wheels up at horizontal position and ensure no load to each wheel.

Shake wheels to left and right to see whether their connecting parts are installed tightly and check whether they can be swung.

No adequate tightening: → tightening

Swing: → replace rocker arm



Tire pressure

Improper tire pressure will lower comfort of operation and driving and may lead to wear to side edges of tires.

	Front wheel	Rear wheel
Rated pressure	62kPa(0.62kgf/cm ²)	62kPa(0.62kgf/cm ²)
Dimension of tire	26×9-14	26×11-14

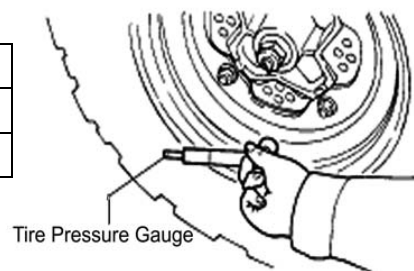

Tire thread.

When the tire groove decreases to 6 mm (0.24 in) due to wear, replace the tire.

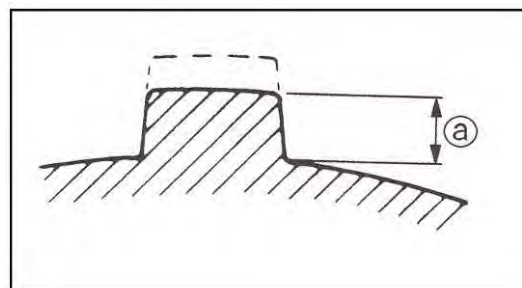

ENGINE COMPRESSION PRESSURE

The compression pressure reading of a cylinder is a good indicator of its internal condition. The decision to overhaul the cylinder is often based on results of a compression test.

Before measuring cylinder pressure, ensure installation and tightening of cylinder cap bolt with designated torque and reasonable clearance of valve.

Standard cylinder pressure: 0.9~1.2Mpa

Too low cylinder pressure may cause the following:

- Excessive wear to cylinder;
- Wear to piston or piston ring;
- Blockage of piston ring in groove;
- Close valve seat;
- Damage to cylinder lining or faults of other parts

Measure engine compression pressure:

1. Warm up engine.
2. Ensure full charging of battery.
3. Remove the relevant plastic parts and accessories from the outside of the engine
4. Dismantle spark plugs.
5. At spark plug hole, install cylinder pressure meter.
6. Press button of start for several seconds. Record indication of maximum cylinder pressure.

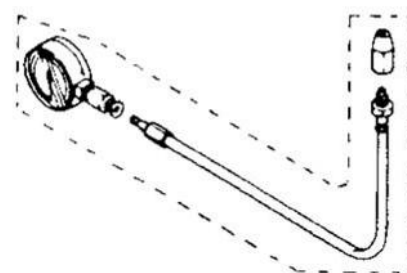

ENGINE OIL PRESSURE

Check the engine oil pressure periodically. This will give a good indication of the condition of the moving parts. The engine oil pressure test should be done with a warm engine 90°C and the recommended oil.

Remove the relevant plastic parts and accessories from the outside of the engine.

Remove the oil pressure switch wire connector and switch on the right of engine.

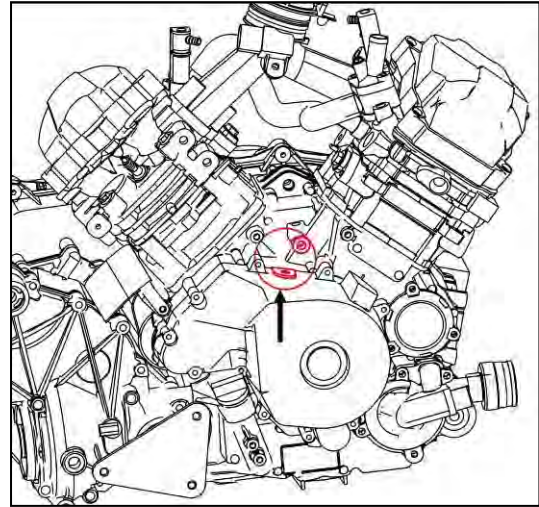

Install oil pressure gauge and adapter hose.

Start engine on idle speed. The engine oil pressure should be within the following values.

Oil pressure	1250 RPM	6000 RPM
Minimal	70 KPa	350 KPa
Nominal	180 KPa	420 KPa
Maximal	300 KPa	550 KPa

Remove oil pressure gauge and adapter hose.

Installation oil pressure switch to 12 N.m and the oil pressure switch wire connector.

Install engine shield gear shift handle globe and left and right seats.

SUSPENSION SYSTEM

Lubricate both suspension arms with lithium-soap based grease. There are two grease fittings on each suspension arm. Check operation and for leakage.

Grease fitting location of front suspension arms.

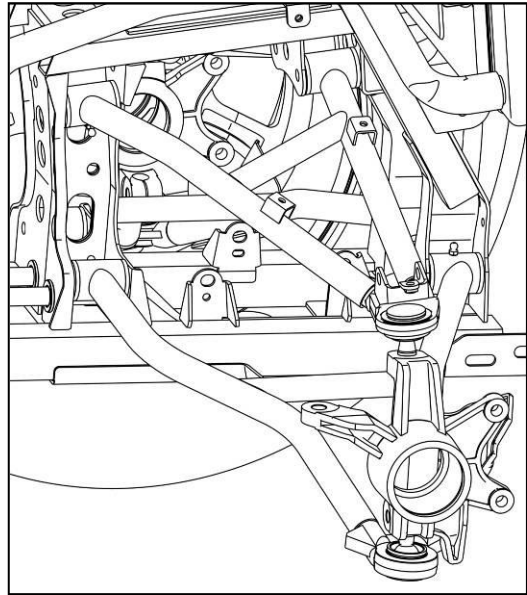

Lubricate rear knuckles with lithium-soap based grease.

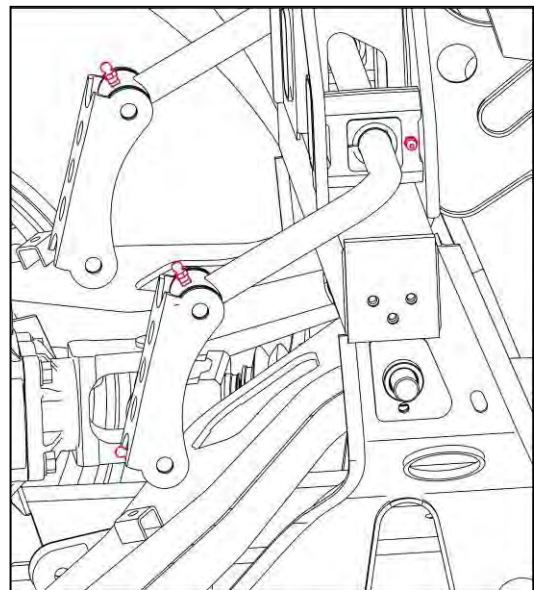

3. ENGINE

ENGINE REMOVAL	3-1	VALVE COVER	3-8
TIMING CHAIN TENSIONER	3-8	CAMSHAFT TIMING GEAR	3-8
ROCKER ARM	3-8	CYLINDER HEAD	3-8
CAMSHAFT	3-8	VALVE SPRING	3-8
VALVE	3-8	VALVE GUIDE	3-8
CYLINDER	3-8	PISTON	3-8
PISTON RINGS	3-8	DRIVE SHAFT	3-8
PTO COVER	3-8	DRIVE GEARS	3-8
TIMING CHAIN	3-8	CRANKCASE	3-8
CRANKSHAFT	3-8	OIL PRESSURE REGULATOR	3-8
OIL PUMP	3-8	MAGNETO COVER	3-8
STATOR	3-8	ROTOR	3-8
SPRAG CLUTCH	3-8	SPRAG CLUTCH GEAR	3-8
TRANSMISSION	3-8	GEAR BOX	3-8
DRIVE BELT	3-8	GEAR BOX OIL DRAIN	3-8
DRIVE PULLEY	3-8	POSITION INDICATOR SWITCHES	3-8
DRIVEN PULLEY	3-8	OIL SEALS	3-8
CVT AIR GUIDE	3-8	OUTPUT SHAFT	3-8
ENGINE INSTALLATION	3-1	GEARS	3-8

Components which are identical for both cylinders/cylinder heads are identified in the two exploded views by the same number. Components which are different or which are, for instance, present on one of the cylinders/cylinder heads but not on the other, have different numbers. The information given below always relates as a general rule.

Special reference is made in the text to work instructions which are not the same for cylinder no. 1 and cylinder no. 2.



1. Cylinder 1
2. Cylinder 2

! WARNING

Torque wrench tightening specifications must strictly be adhered to.

Locking devices (e.g.: locking tabs, elastic stop nuts, self-locking fasteners, cotter pin, etc.) must be installed or replaced with new ones where specified. If the efficiency of a locking device is

When diagnosing an engine problem, always perform a cylinder leak test. This will help pin-point a problem. Refer to

the instructions included with your leak tester and to LEAK TEST section for procedures.
Always place the vehicle on level surface.

NOTE: For a better understanding, the many illustrations are taken with engine out of vehicle. To perform the following instructions, it is not necessary to remove engine from vehicle.

Always disconnect BLACK (-) cable from the battery, then RED (+) cable before working on the engine.
Even if the removal of many parts is not necessary to reach another part, it is recommended to remove these parts in order to check them.

When disassembling parts that are duplicated in the engine, (e.g.: valves), it is a strongly recommended to note their position (PTO/MAG side, front/rear cylinder) and keep them as a “group”. If you find a defective component, it would be must easier to find the cause of the failure among it group of parts (e.g.: you found a worn valve guide. A bent spring could be the cause and it will be easy to know which one among the springs is the cause to replace it if you grouped them at disassembly). Also, since used pars have matched together during the engine operation, they will keep their matched fit when you reassemble them together within their “group”.

ENGINE REMOVAL

To avoid potential burns, let engine and exhaust system cool down before performing any servicing.

Place vehicle on a work station that will have access to an engine-lifting hoist. Then start with initial preparation of vehicle.

Disconnect the BLACK(-) cable from battery, then the RED(+) cable.

Drain coolant from engine cooling system. Drain engine oil only if engine overhaul is necessary. To work on gearbox the removal is necessary but do not drain engine oil.

VALVE COVER

Cover Removal

Remove:

- distance screws of valve cover

1. Distance screws
2. Valve cover

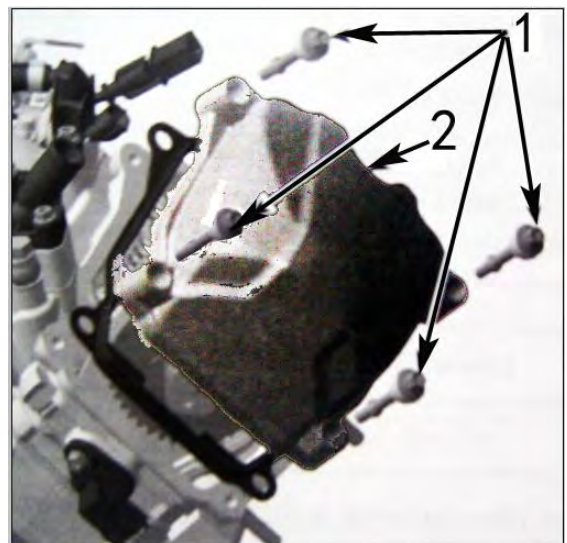

- valve cover and gasket.

1. Valve cover
2. Gasket

Repeat the procedure for the other valve cover if required.

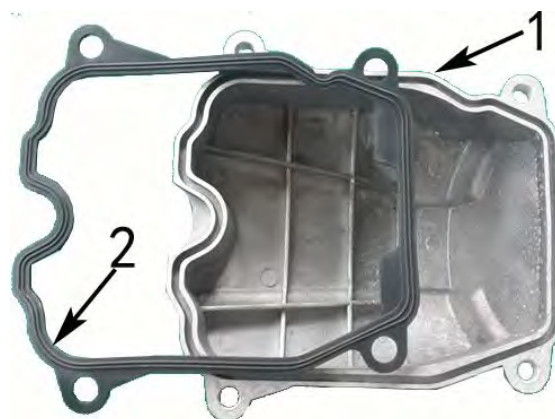

Cover Inspection

Check the gasket on the valve cover if it is brittle, cracked or hard. If so, replace the gasket.

Cover Installation

For installation, reverse the removal procedure.

Torque the valve cover distance screws in a criss-cross sequence.

TIMING CHAIN TENSIONER

NOTE: Before removal and installation, make sure that the respective cylinder is set to TDC ignition. Refer to CAMSHAFT.

Tensioner removal

! WARNING

Timing chain tensioner is spring loaded. Never perform this operation immediately after the engine has been turn because the exhaust system can be very hot. Wait until exhaust system is warm or cold.

Remove:

- chain tensioner plug
- O-ring
- Spring
- Chain tensioner plunger

1. Chain tensioner plug
2. O-ring
3. Spring
4. Chain tensioner plunger

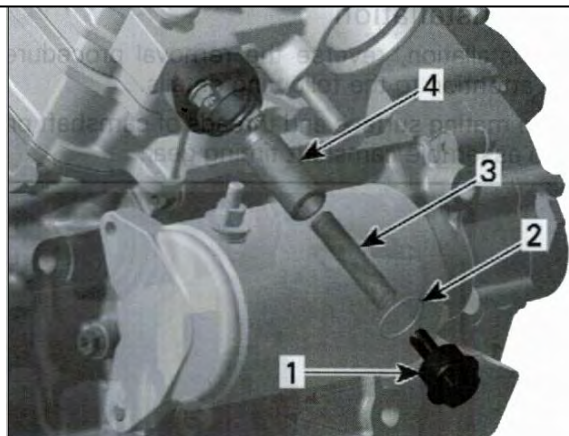

Screws retaining chain tensioner housing



■ Chain tensioner housing with O-ring

1. Chain tensioner screws
2. Chain tensioner housing
3. O-ring

Tensioner Inspection

Check the housing for cracks or other damages.

Replace if necessary.

Check chain tensioner plunger for free movement and/or scoring.

Check if O-rings are brittle, cracked or hard. Replace if necessary.

Check spring condition. Replace if broken or worn.

Tensioner Installation

For installation, reverse the removal procedure. However, pay attention to the following.

NOTE: Before installing the chain tensioner make sure, that the camshaft timing gear can be moved back and forth.

Apply engine oil on the plunger before installing.

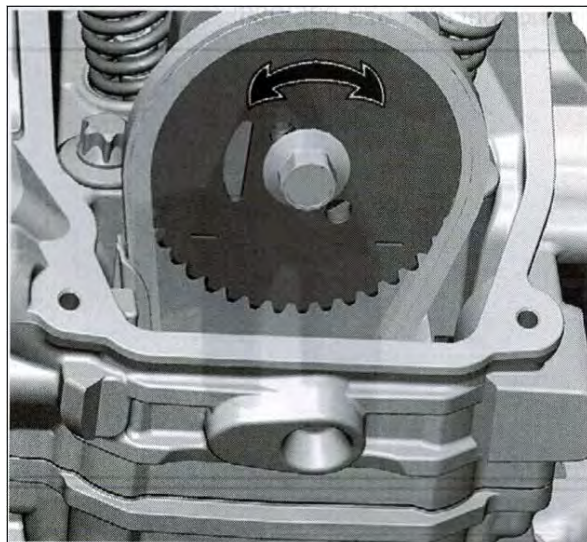

NOTE: Slightly screw in the plunger until the timing chain allows no more back and forth movement of the camshaft timing gear. Then screw in the plunger an additional 1/8 turn to reach the required torque of 0.1 N.m.

CAUTION: Improper adjustment of the timing chain will lead to severe engine damage.

Fit the spring on one side into the slot of the plug screw and on the other side into the plunger. Turn spring only clockwise in order to fit the spring end into the notch of the plunger and to avoid loosening the plunger during spring installation. Do not preload the spring.

NOTE: Do not forget to place the O-ring on chain tensioner plug.

Then compress the spring and screw in plug screw.

Finally, tighten the plug screw to 4.5 N.m.

CAMSHAFT TIMING GEAR

Gear Removal

Turn crankshaft to TDC ignition of the respective cylinder.

Unscrew timing chain tensioner.

Remove camshaft timing gear screw.

1. Camshaft timing gear screw
2. Camshaft timing gear

Remove the camshaft timing gear.

NOTE: Secure timing chain with a retaining wire.

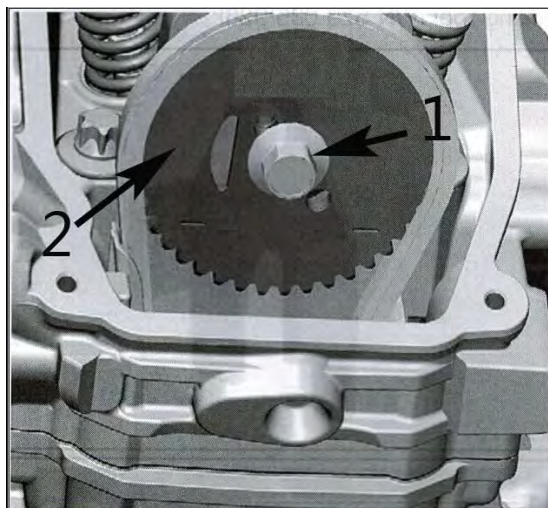

Gear Inspection

Check camshaft timing gear for wear or deterioration.

If gear is worn or damaged, replace it as a set (camshaft timing gear and timing chain).

Gear Installation

For installation, reverse the removal procedure. Pay attention to the following details.

Clean mating surface and threads of camshaft, prior to assemble camshaft timing gear.

1. Mating surface on camshaft
2. Threads for camshaft screw

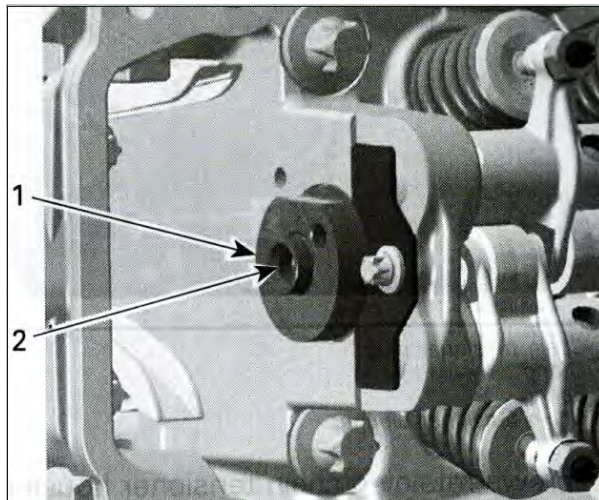

Camshaft timing gear and crankshaft must be at TDC ignition position before installing the timing chain.

CAUTION: Crankshaft and camshaft must be locked on TDC ignition position to place camshaft timing gear and timing chain in the proper position.

Install camshaft timing gear so that the timing gear tabs are located into the flat zone of the camshaft.

The printed marks on the camshaft timing gear must be parallel to the cylinder head base. See the following illustration for a proper positioning.

1. Printed marks on camshaft timing gear
2. Cylinder head base
3. Camshaft timing gear
4. Timing gear tab

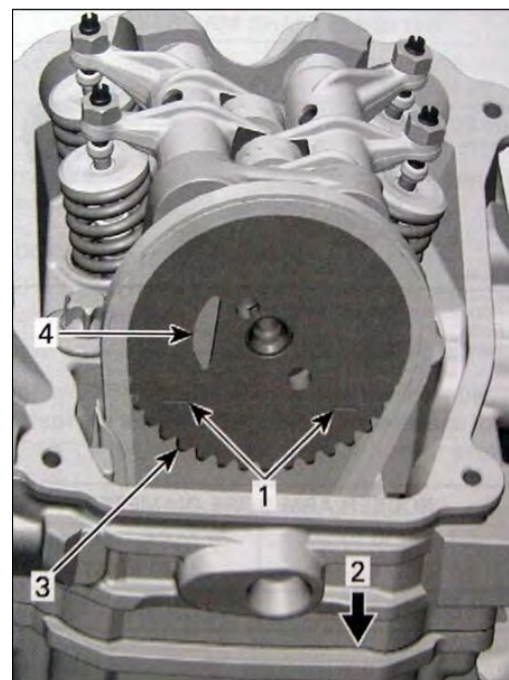

Install trigger wheel on camshaft timing gear of cylinder 1.

1. Camshaft timing gear screw
2. Camshaft timing gear

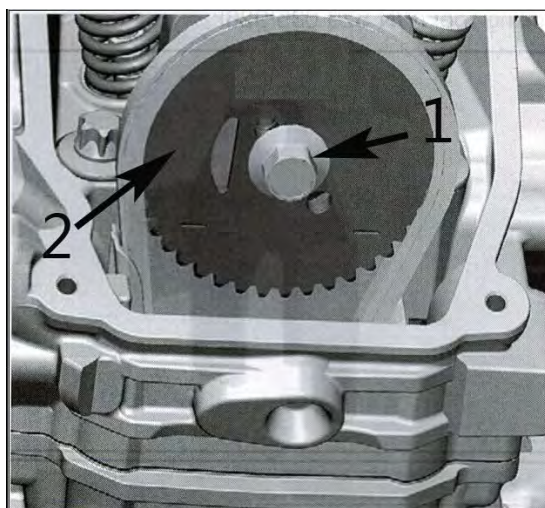

When the camshaft timing gear and the timing chain are installed, remove the crankshaft locking bolt as well as the camshaft locking tool.

NOTE: Before installing the camshaft screw adjust the chain tension and check again if marks on the timing gear are parallel to cylinder head base.

Reinstall all other removed parts.

ROCKER ARM

Rocker Arm Removal

Remove:

- valve cover
- chain tensioner
- camshaft timing gear
- Allen screw and camshaft retaining plate

1. Cylinder head
2. Allen screw
3. Camshaft retaining plate
- Rocker arm shafts
- Rocker arm assembly (exhaust side and intake side) with adjustment screws and nuts.

1. Rocker arm shaft
2. Rocker arm (exhaust side)
3. Rocker arm (intake side)
4. adjustment screw
5. Locking nut

- Thrust washer

CAUTION: Pay attention not to lose thrust washers or drop them into the timing chain compartment.

Rocker Arm Inspection

Inspect each rocker arm for cracks and scored friction surfaces. If so, replace rocker arm assembly.

Check the rocker arm rollers for free movement, wear and excessive radial play. Replace rocker arm assembly if necessary.

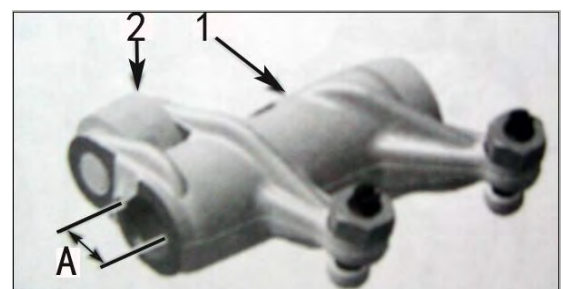
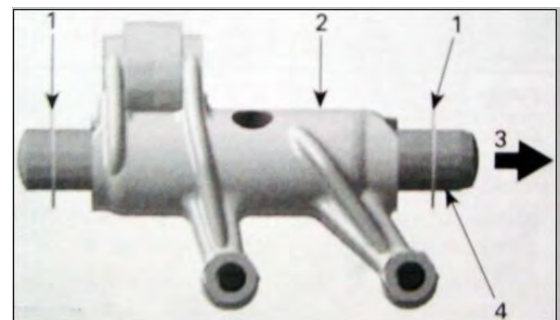
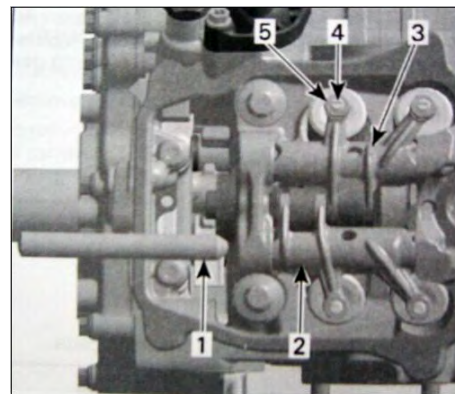
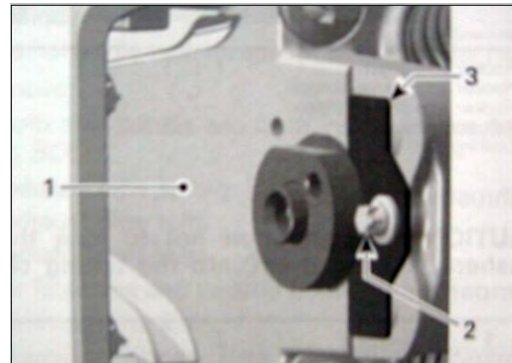

1. Rocker arm (exhaust side)
2. Roller
3. Bore for rocker arm shaft

Measure rocker arm bore diameter. If diameter is out of specification, change the rocker arm assembly.

Rocker arm bore diameter	
new	12.000 to 12.018 mm
Service limit	12.030 mm

Check adjustment screws for free movement, cracks and/or excessive play.

1. Free movement of adjustment screw top



Rocker arm shaft

Check for scored friction surfaces, if so, replace parts.

Measure rocker arm shaft diameter.

A: Measure rocker arm shaft diameter here

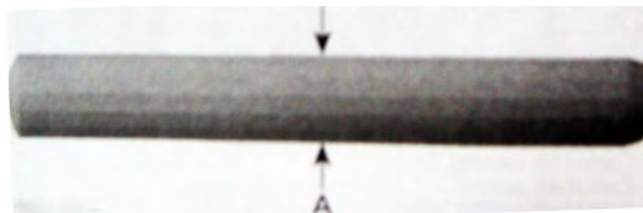

Rocker arm shaft diameter	
New	11.983 to 11.994 mm
Service limit	11.970 mm

Any area worn excessively will require parts replacement.

Rocker Arm Installation

NOTE: use the same procedure for exhaust and intake rocker arm.

Apply engine oil on rocker arm shaft.

Install the rocker arm shafts with the chamfered edge first and use following procedure:

- Insert a rocker arm pin through rocker arm pin bore.
- Install a thrust washer then the proper rocker arm.
- Push in rocker arm shaft until its chamfer reaches the end of rocker arm bore.

1. Rocker arm shaft
2. Thrust washer (timing chain side)
3. Thrust washer (spark plug side)

- Place the other thrust washer and push rocker arm shaft to end position.
- Install the camshaft retaining plate no. 5.

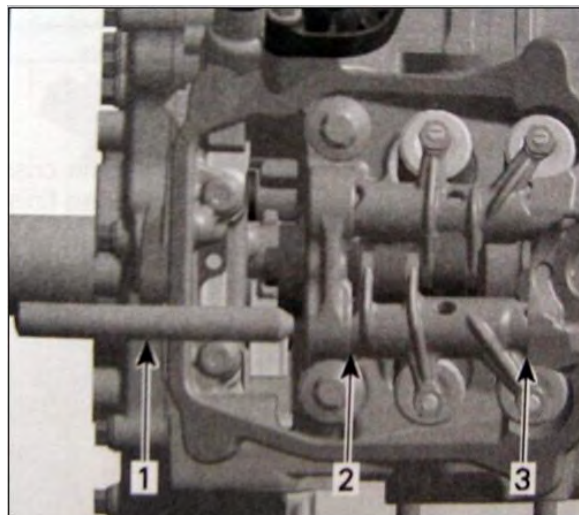

CYLINDER HEAD

Cylinder Head Removal

The removal procedure is the same for both cylinder heads.

Drain coolant.

CAUTION

Before removing cylinder head, blow out remaining coolant by air pressure. During cylinder head removal, the remaining coolant in cylinder head could overflow into the engine and a little quantity of coolant could drop into the engine. In this case, the engine oil will be contaminated. controlled.

Disconnect:

- spark plug wire
- temperature sensor connector, located at rear cylinder head

Remove:

- exhaust pipe spring
- exhaust pipe nuts
- radiator inlet hose
- air filter box and throttle body
- air intake manifold
- chain tensioner
- valve cover and gasket
- camshaft timing gear
- cylinder head screws M6
- cylinder head screws M10 retaining cylinder head and cylinder to cylinder base.

1. Cylinder head screws M10
2. Cylinder head screws M6

Pull up cylinder head.

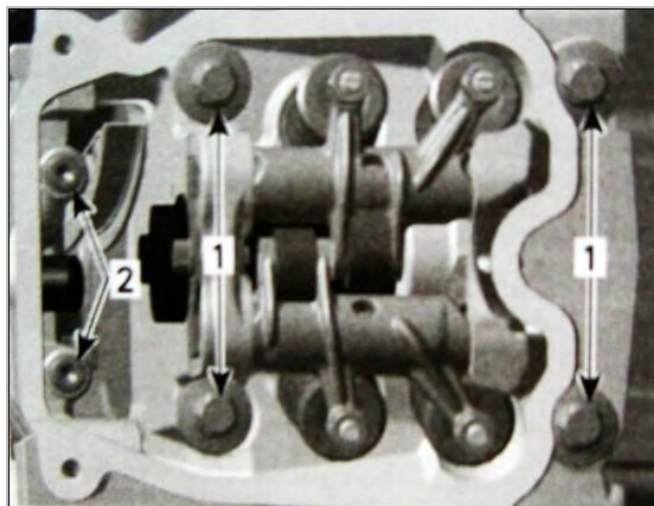

Remove:

- chain guide
- cylinder head gasket and scrap it.

1. Cylinder head
2. Timing chain
3. Chain guide
4. Cylinder head gasket

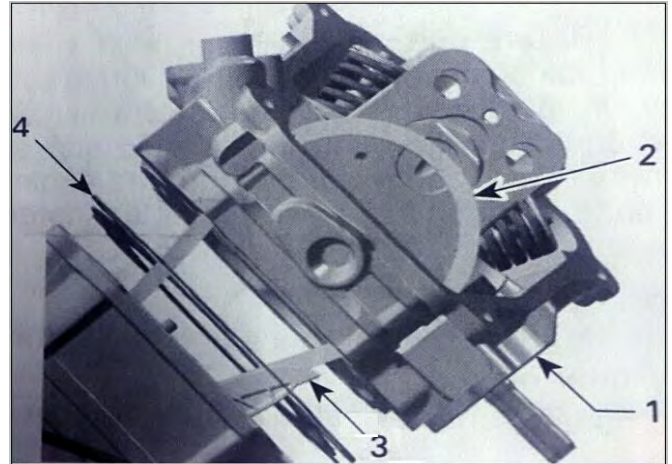

Cylinder Head Inspection

Inspect timing chain guide for wear, cracks or other damages. Replace if necessary.

Check for cracks between valve seats, if so, replace cylinder head.

Check mating surface between cylinder and cylinder head for contamination. If so, clean both surfaces.

Clean oil support through the cylinder head from contamination.

1. Oil port to lubricate camshaft lobes intake/exhaust
2. Oil supply to camshaft bearing journal timing chain side
3. Oil supply to camshaft bearing journal spark plug side

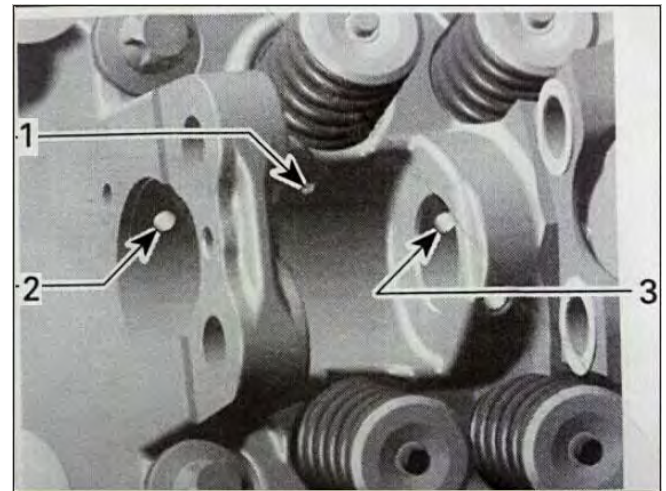

Cylinder Head Installation

NOTE: The cylinder heads are not identical in design. Do not invert the cylinder heads at assembly.

For installation, reverse the removal procedure. Pay attention to the following details.

Ensure dowel pins are in place.

CAUTION: Chain guide has to be fixed between cylinder and cylinder head.

1. Chain guide (fixed between cylinder and cylinder head)

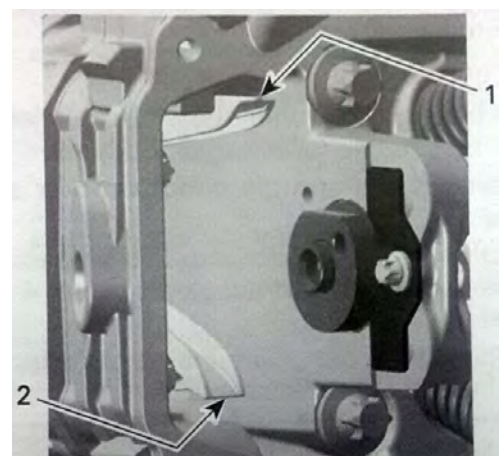

2. Chain tensioner guide (mounted in crankcase)

Install a new cylinder head gasket.

First, torque cylinder head screws M 10 in crisscross sequence to 20 N.m then finish by tightening to 60 N.m.

Install cylinder head screws M6.

1. Cylinder head screws M10
2. Cylinder head screws M6

Check chain guide for movement.

Remove crankshaft locking bolt and reinstall plug screw with sealing ring.

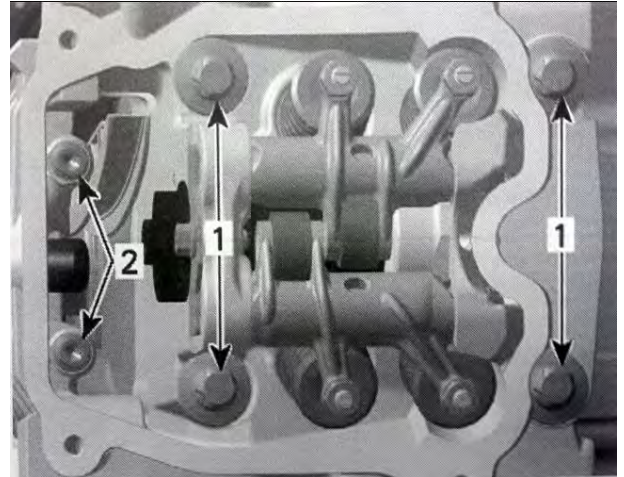

CAMSHAFT

NOTE: The engine is equipped with two different camshafts.

1. Camshaft of cylinder 1
2. Camshaft of cylinder 2



Camshaft timing cylinder 2

Turn crankshaft until piston is at TDC ignition as follows.

Remove:

- spark plug cable and spark plug of both cylinders
- valve cover of both cylinders
- plug screw and O-ring of magneto cover

1. Plug screw
2. O-ring



- crankshaft position sensor

1. Crankshaft position sensor
2. Screw

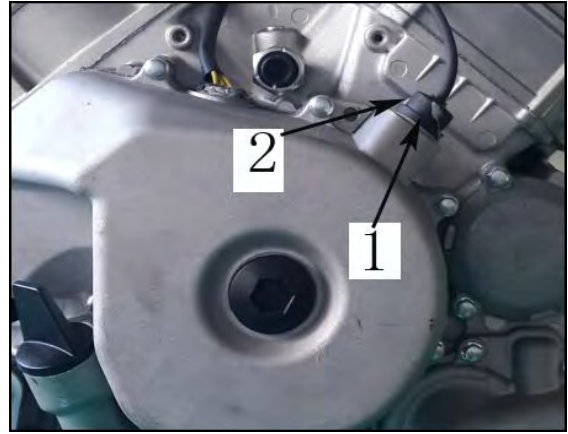

Use a 14 mm Allen key to turn crankshaft until piston 2, rear is at TDC ignition.

1. Allen key 14 mm



When rear piston is at TDC ignition, marks on magneto flywheel "2" and on the magneto cover are aligned.

1. Mark "2" on magneto flywheel
2. Notch on magneto cover
3. Crankshaft position sensor location

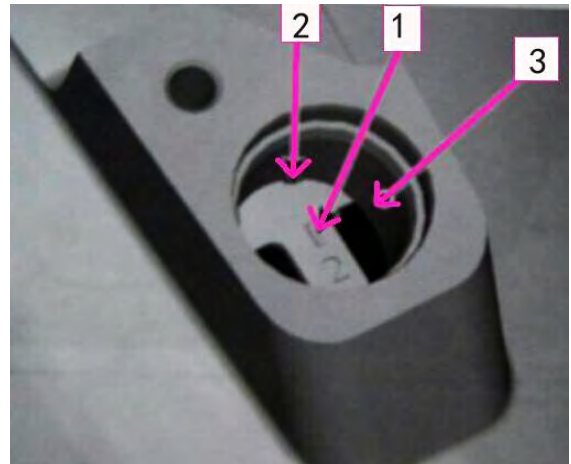

At TDC ignition, the printed marks on the camshaft timing gear have to be parallel to cylinder head base.

1. Printed marks on camshaft timing gear
2. Cylinder head base

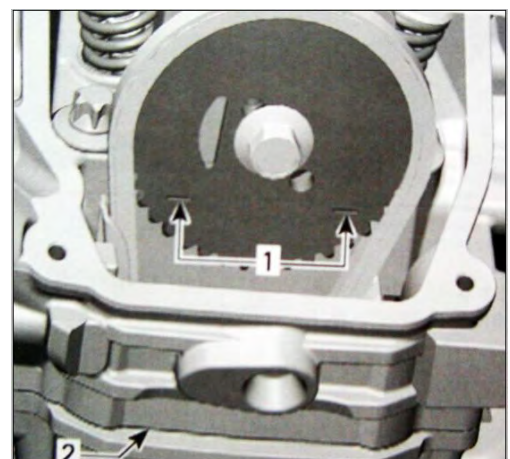

To lock crankshaft at TDC ignition, proceed as follows.

Remove from crankcase plug screw with sealing ring.

- 1 Plug screw
- 2 Sealing ring
- 3 Crankcase PTO side, front side

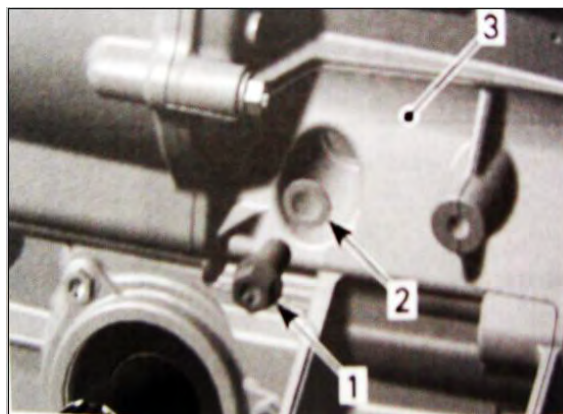

Lock crankshaft with crankshaft locking bolt.

1. Crankshaft locking bolt

NOTE: Make sure the locking bolt engages in the groove of the crankshaft.



Camshaft Timing Cylinder 1

Using a 14 mm Allen key, turn crankshaft 280 °counterclockwise, until marks on magneto flywheel “1” and magneto cover are aligned.

1. Allen key 14mm
2. Turn crankshaft 280°counterclockwise



1. Mark “1” on magneto flywheel
2. Notch on magneto cover
3. Location of crankshaft position sensor

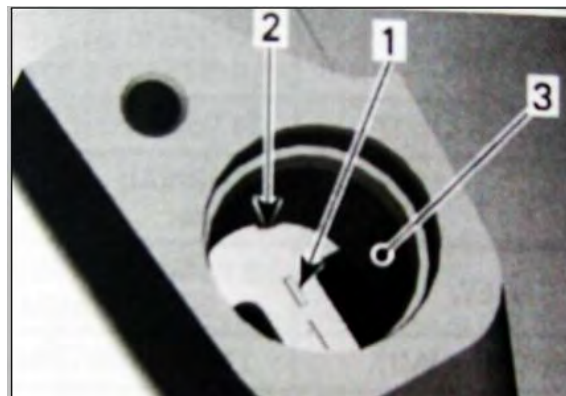

NOTE: At TDC ignition, the printed marks on the camshaft timing gear have to be parallel to cylinder head base as per following illustration.

1. Printed marks on camshaft timing gear
2. Cylinder head base

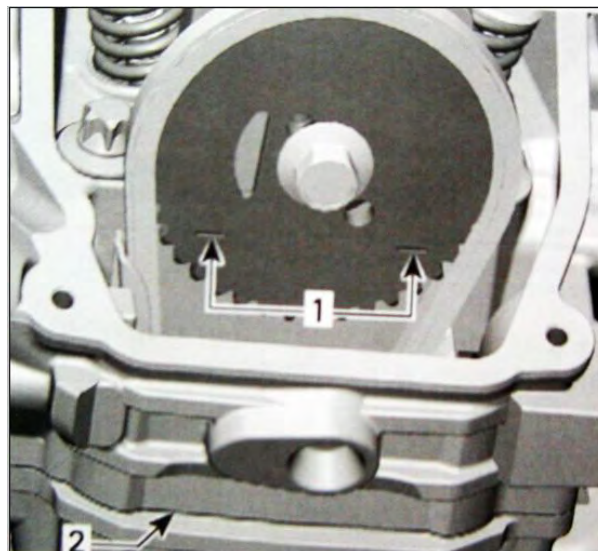

CAUTION: Crankshaft can not be locked at cylinder 1 TDC ignition.

Camshaft Removal

The removal procedure is the same for both camshafts.

Each camshaft is different in design. Thus, it is important not to mix up any parts of the camshaft assembly with that of the other cylinder. Keep parts as a group.

Remove:

- valve cover (see VALVE COVER above)
- chain tensioner (see CHAIN TENSIONER above)
- camshaft timing gear (see CAMSHAFT TIMING GER above)
- camshaft retaining plate

1. Cylinder head
2. Allen screw
3. Camshaft retaining plat

- rocker arms (see ROCKER ARM above)
- camshaft.

NOTE: For removal rotate camshaft so that intake/exhaust lobe shows to upper side of cylinder head.

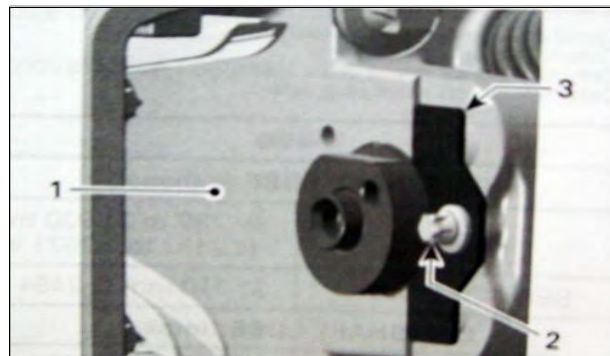

1. Area for camshaft lobes
2. Camshaft
3. Camshaft retaining

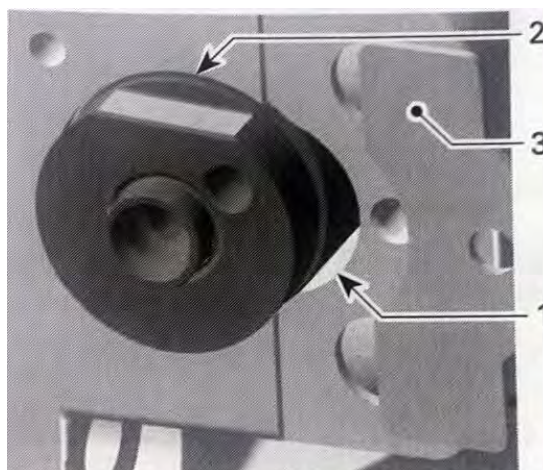

Camshaft Inspection

Check each lobe and bearing journal of camshaft for scoring, scuffing, cracks or other signs of wear.
 Measure camshaft bearing journal diameter and lobe height using a micrometer.

- A. Camshaft lobe (exhaust valves)
- B. Camshaft lobe (intake valves)
- C. Camshaft journal timing chain side
- D. Camshaft journal spark plug side

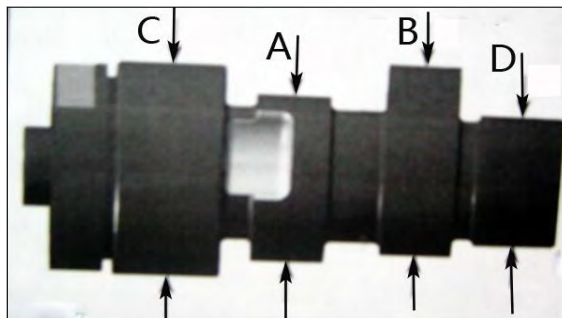

Camshaft lobe (exhaust)	
New	31.95 to 32.05mm
Service limit	31.92mm
Camshaft lobe (intake)	
New	32.15 to 32.25 mm
Service limit	32.09 mm

Camshaft journal(timing chain side)	
New	34.95 to 34.975 mm
Service limit	34.94mm
Camshaft journal (spark plug side)	
New	35 to 35.025 mm
Service limit	35.04 mm

Measure clearance between both ends of camshaft and cylinder head. Replace parts that are not within specifications.

- A. Cylinder head camshaft bearing timing chain side
- B. Cylinder head camshaft bearing spark plug side

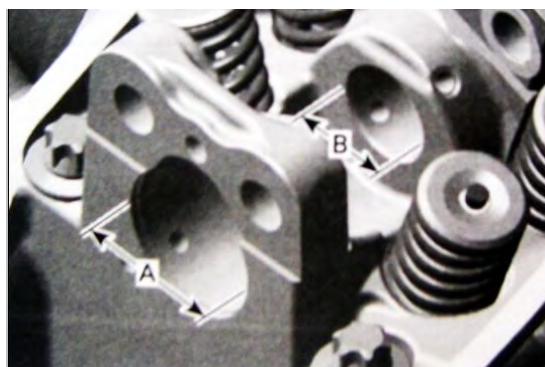

Cylinder head camshaft bearing(timing chain side)	
New	35.000 to 35.025 mm
Service limit	35.040 mm
Cylinder head camshaft bearing(spark plug side)	
New	22.000 to 22.021 mm
Service limit	22.040 mm

Camshaft Installation

For installation, reverse the removal procedure. Pay attention to the following details.

CAUTION: the camshafts are not identical in design. Do not invert the camshafts during assembly. Any mix-up of the components will lead to engine damage.

Place the camshaft retaining plate in the slot of the camshaft.

- 1. Camshaft retaining plate position

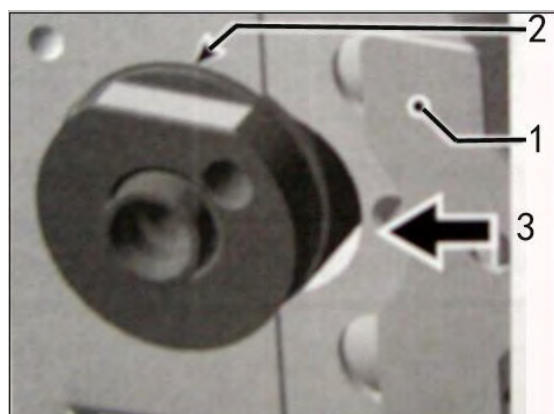

2. Slot retaining camshaft
3. Direction of movement

For other parts, refer to proper installation procedure.

VALVE SPRING

Valve Spring Removal

Remove:

- rocker arms (see ROCKER ARM above)
- cylinder head (see CYLINDER HEAD above).

Compress valve spring; use valve spring compressor clamp and valve spring compressor cup.



! WARNING

Always wear safety glasses when disassembling valve springs. Be careful when unlocking valves. Components could fly away because of the strong spring preload .

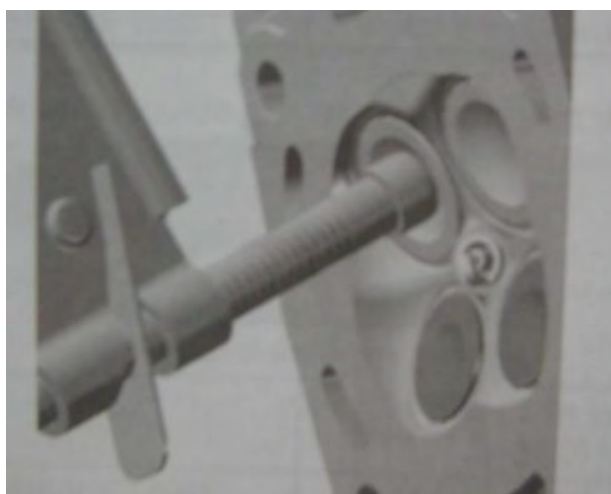

Remove valve cotters.

1. Valve spring compressor clamp
2. Valve spring compressor cup
3. Valve cotter

Withdraw valve spring compressor, valve spring retainer and valve spring .

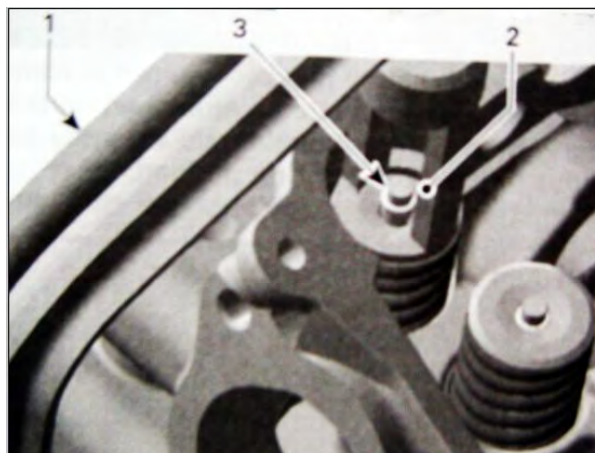

Valve Spring Inspection

Check valve spring for visible damages. If so, replace valve spring.

Check valve spring for free length and straightness. Replace valves springs if not within specifications.

A. Valve spring length

Valve spring free length		
Nominal	New	40.5 mm
	Service limit	39.00 mm

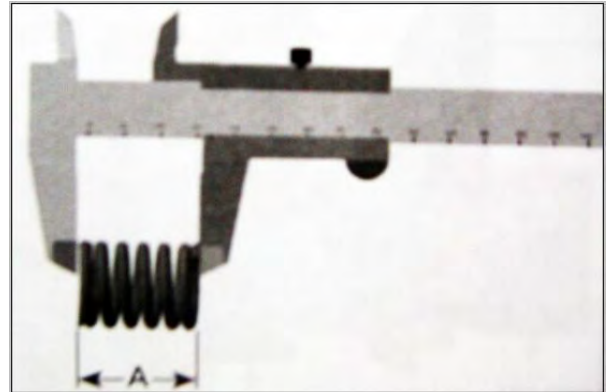

Valve Spring Installation

For installation, reverse the removal procedure. Pay attention to the following details.

Colored area of the valve spring must be placed on top.

To ease installation of cotters, apply oil or grease on them so that they remain in place while releasing the spring.

NOTE: Valve cotter must be properly engaged in valve stem grooves.

1. Position of the spring
2. Valve cotter

After spring is installed, ensure it is properly locked by tapping on valve stem end with a soft hammer so that valve opens and closes a few times.

CAUTION: An improperly locked valve spring will cause engine damage.

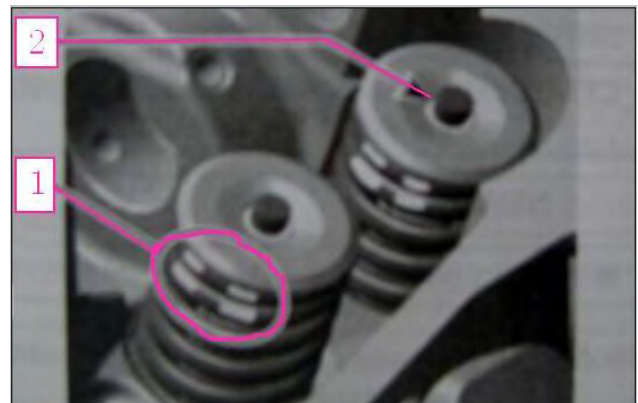

VALVE

VALVE Removal

Remove valve spring, see VALVE SPRING above. Push valve stem, then pull valves (intake and exhaust) out of valve guide.

1. Intake valves 31mm
2. Exhaust valve 27mm

Remove valve stem seal with Snap-On pliers and discard it.

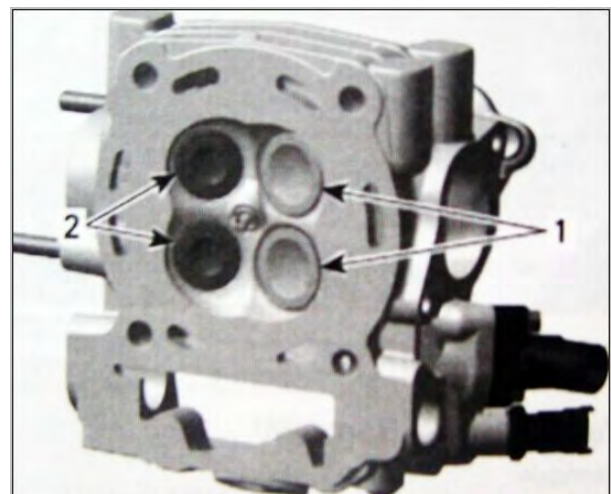

Valve Inspection

Valve Stem seal

Always install new seals whenever valves are removed.

Valve

Inspect valve surface, check for abnormal stem wear and bending .If out of specification, replace by a new one.

Valve out of round(intake and exhaust valves)	
New	0.006 mm
Service limit	0.06 mm

Valve Stem and Valve Guide Clearance

Measure valve stem and valve guide in three places using a micrometer and a small bore gauge.

NOTE: Clean valve guide to remove carbon deposits before measuring.

Change valve if valve stem is out of specification or has other damages such as wear or friction surface.

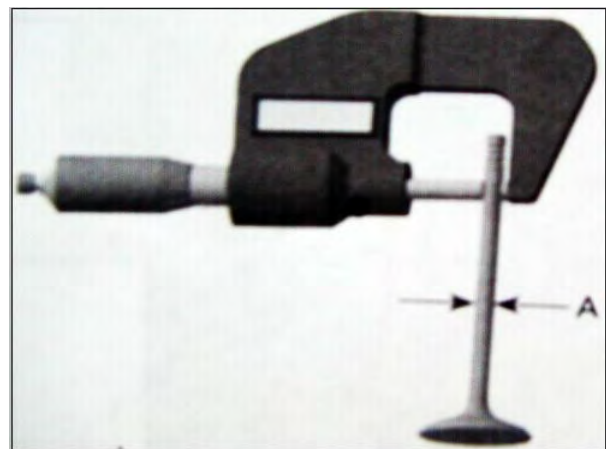

A. Valve stem diameter

Valve stem diameter	
Exhaust valve	
New	4.945 to 4.965 mm
Service limit	4.930 mm
Intake valve	
New	4.960 to 4.975 mm
Service limit	4.930 mm

Replace valve guide out of cylinder head if valve guide or out of specification or has other damages such as wear or friction surface (see VALVE GUIDE PROCEDURE below)

Valve guide diameter(intake and exhaust valves)	
New	5.006 to 5.015 mm
Service limit	5.050 mm

Valve Face and Seat

1. Valve seat
2. Exhaust valve contaminated
3. Valve face (contact surface to valve seat)

Check valve face and seat for burning or pitting.

and replace valve or cylinder head if there are signs of damage.

Ensure to seat valve properly. Apply some lapping compound to valve face and work valve on its seat with a lapping tool (see VALVE GUIDE

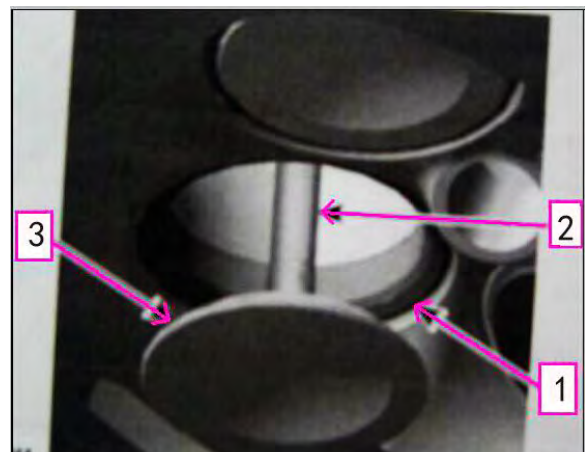

PROCEDURE below).

Measure valve face contact width.

NOTE: The location of contact area should be in center of valve seat.

Measure valve seat width using a caliper.

If valve seat contact width is too wide or has dark spots, replace the cylinder head.

- A. Valve face contact width
- B. Valve seat contact width

Valve seat contact width	
Exhaust valve	
New	1.25 to 1.55 mm
Service limit	2.00 mm
Intake valve	
New	1.05 to 1.35 mm
Service limit	1.80 mm



Valve installation

For installation, reverse the removal procedure. Pay attention to the following details.

Install a NEW valve stem seal. Make sure thrust washer is installed before installing seal.

Apply engine oil on valve stem and install it.

CAUTION: Be careful when valve stem is passed through sealing lips of valve stem seal.

1. Thrust washer
2. sealing lips of valve stem seal.

To ease installation of cotters, apply oil or grease on them so that they remain in place while releasing the spring.

After spring is installed, ensure it is properly locked by tapping on valve stem end with a soft hammer so that valve opens and closes a few times.

CAUTION: An improperly locked valve spring will cause engine damage.

VALVE GUIDE

Valve Guide Removal

Remove:

- cylinder head (see *CYLINDER HEAD* above)
- valve spring (see *VALVE SPRING* above)
- valves (see *VALVE* above)

NOTE: Clean valve guide area from contamination before removal.

Using valve guide remover, remove valve guide with a hammer.

1. Valve guide remover
2. Valve guide



Valve Guide Inspection

Always replace valve stem seals whenever valve guides are removed.

Clean the valve guide bore before reinstalling the valve guide into cylinder head.

Valve Guide Installation

For installation, reverse the removal procedure. Pay attention to the following details.

Use valve guide installer to install valve guide.

NOTE: Apply LOCTITE 767 on valve guide prior to install it into the cylinder head.

Valve guide to be adjusted in diameter by using a reamer.

NOTE: Ensure to turn reamer in the right direction.

Using cutting oil and make passes to clean reamer/valve guide from metal shavings.

Apply some lapping compound to valve face and work valve on its seat with a lapping tool.

1. Valve seat
2. Valve face (contact surface to valve seat)
3. Turn valve while pushing against cylinder head
- A. Valve seat angle 45°.



Valve guide diameter (intake and exhaust valves)	
new	5.006 to 5.015 mm
Service limit	5.050mm

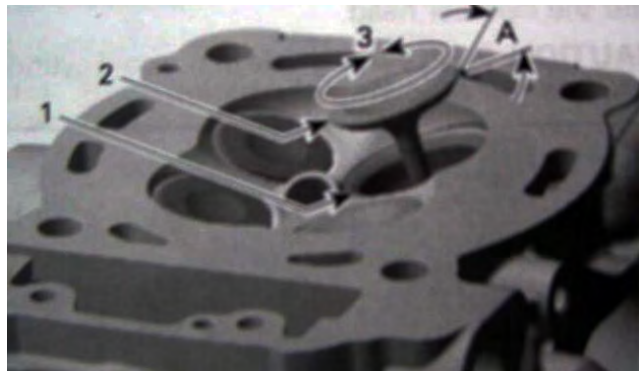

NOTE: Ensure to seat valves properly. Apply marking paste to ease checking contact pattern. Repeat procedure until valve seat/valve face fits together.

CYLINDER

Cylinder removal

Remove:

- Chain tensioner (see CHAIN TENSIONER)
- camshaft timing gear (see CAMSHAFT TIMING GEAR)
- cylinder head (see CYLINDER HEAD)

Pull cylinder.

Discard cylinder base gaskets.

1. Cylinder
2. Piston assembly
3. Cylinder base gasket
4. Camshaft timing chain



Cylinder Inspection

Check cylinder for cracks, scoring and wear, ridge on the top and bottom of the cylinder. If so, replace cylinder.

Cylinder taper

Measure cylinder bore and if it is out of specifications, replace cylinder and piston rings.

Measure cylinder bore at 3 recommended positions. See the following illustration.

1. First measuring of diameter
2. Second measuring of diameter
3. Third measuring of diameter
- A. 7mm from cylinder bottom
- B. 68mm
- C. 32mm



Distance between measurements should not exceed the service limit mentioned above.

Cylinder taper in diameter	
New (maximum)	0.033-0.048 mm
Service limit	0.090 mm

Cylinder out of Round

Measure cylinder diameter in piston axis direction from top of cylinder. Take another measurement 90 °from first one and compare.

NOTE: Take the same measuring points like described in *CYLINDER TAPER* above.

- A. Perpendicular to crankshaft axis
- B. Parallel to crankshaft axis

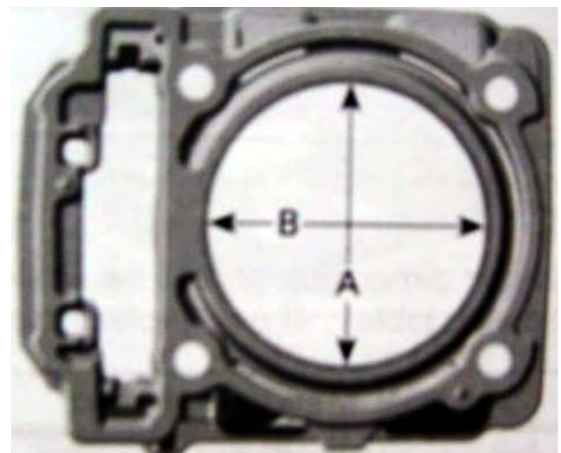

Cylinder out of round	
New (maximum)	0.003 mm
Service limit	0.020 mm

Cylinder Installation

For installation, reverse the removal procedure. Pay attention to the following details.

CAUTION: Always replace cylinder base gasket before installing the cylinder.

First mount cylinder 2. then remove crankshaft locking bolt. Crank the engine further and position piston 1 at TDC. Mount cylinder 1. The cylinder can not be pushed fully over the piston unless the piston is located at TDC.

Apply engine oil in the bottom area of cylinder bore and also on the band of the piston ring compressor tool.

1. Piston ring compressor
2. Piston
3. Cylinder

NOTE: Put timing chain through the chain pit then put the cylinder in place.

CAUTION: Chain guide has to be fixed between cylinder and cylinder head.

NOTE: After both cylinders are installed, turn crankshaft until piston of cylinder 2 is at TDC ignition and lock crankshaft. Install cylinder head and the other parts in accordance with the proper installation procedures.

PISTON AND RINGS

Piston removal

Remove:

- cylinder head (see CYLINDER HEAD above)
- cylinder (see CYLINDER above).

Place a rag under piston and in the area of timing chain compartment.

Remove one piston circlip and discard it.

NOTE: The removal of both piston circlips is

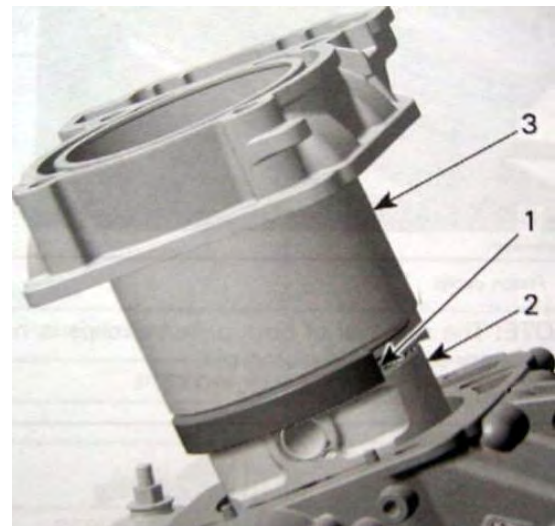

not necessary to remove piston pin.
 Push piston pin out of piston.

1. Piston
2. Piston Pin

Detach piston from connecting rod.



Piston Inspection

Inspect piston for scoring, cracking or other damages. Replace piston and piston rings if necessary.

Using a micrometer, measure piston at 8 mm perpendicularly (90°) to piston pin.

1. Measuring perpendicularly to piston pin
 - A. 8 mm

The measured dimension should be as described in the following tables. If not, replace piston.

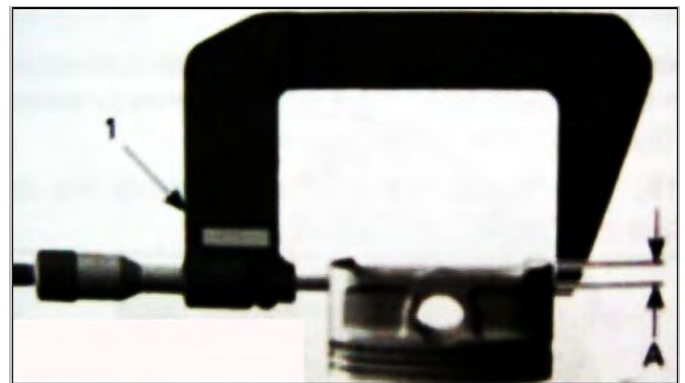

Piston measurement	
Size "A"	
New	90.955 to 90.962mm
Service limit	90.930mm
Size "B"	
New	90.962 to 90.970 mm
Service limit	90.940mm

Piston/Cylinder Clearance

Adjust and lock a micrometer to the piston dimension .

1. Micrometer set to the piston dimension



With the micrometer set to the dimension, adjust a cylinder bore gauge to the micrometer dimension and set the indicator to 0 (zero).

1. Use the micrometer to set the cylinder bore gauge
2. Dial bore gauge



1. Indicator set to 0

Position the dial bore gauge 20 mm above cylinder base, measuring perpendicularly (90°) to piston pin axis.

Read the measurement on the cylinder bore gauge. The result is the exact piston/cylinder wall clearance.

Piston/cylinder clearance	
v-800	
New	0.033 to 0.048 mm
Service limit	0.09 mm

NOTE: Make sure used piston is not worn.

If clearance exceeds specified tolerance; replace piston by a new one and measure piston/cylinder clearance again. Make sure the cylinder bore gauge indicator is set exactly at the same position as the micrometer, otherwise the reading will be false.



Connecting Rod/Piston Pin clearance

Using synthetic abrasive woven clean piston pin from deposits .

Inspect piston pin for scoring, cracking or other damages.

Measure piston pin. See the following illustration for the proper measurement positions.

A. Piston pin diameter

Piston pin diameter	
New	19.996 to 20.000 mm
Service limit	19.980 mm

Replace piston pin if diameter is out of specifications.

Measure inside diameter of connecting rod small end bushing .

1. Bore gauge
2. Connecting rod

Connecting rod small end diameter	
New	20.010 to 20.020 mm
Service limit	20.060 mm

Replace connecting rod if diameter of

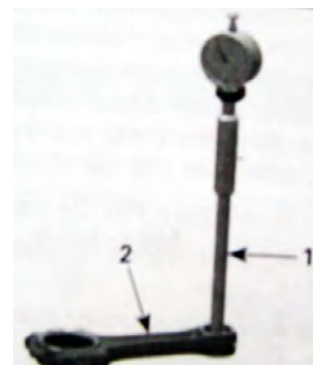
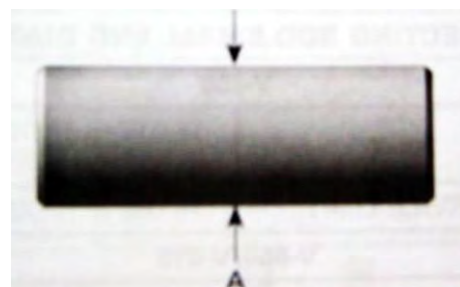

connecting rod small end is out of specifications.

Piston Installation

For installation, reverse the removal procedure. Pay attention to the following details.

Apply engine oil on the piston pin.

Insert piston pin into piston and connecting rod.

1. Piston of cylinder 1
2. Mark on piston must show to exhaust side of cylinder1
3. Piston of cylinder2
4. Mark on piston must show to exhaust side of cylinder 2

CAUTION: Take care that pistons will be installed with the punched arrow on piston top direction to the rear side of the engine.

Front cylinder: Mark on top of piston must show to intake side.

Rear cylinder: Mark on top of piston must show to exhaust side.

1. Piston of cylinder 1
2. Mark on piston must show to intake side of cylinder 1
3. Piston of cylinder 2
4. Mark on piston must show to exhaust side of cylinder 2

CAUTION: Always replace disassembled piston circlip(s) by new ones. Place a rag on cylinder base to avoid dropping the circlip inside the engine.

NOTE: Take care that the hook of the piston circlip is positioned properly.

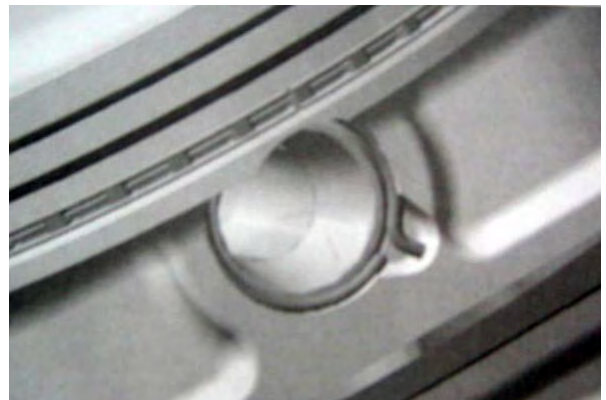
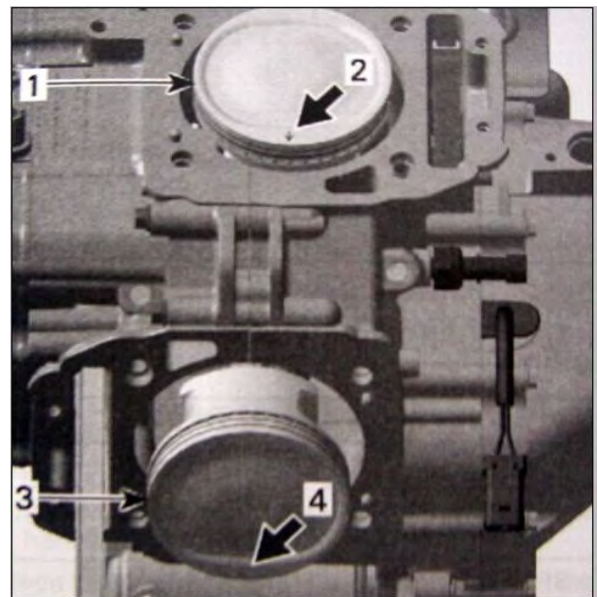
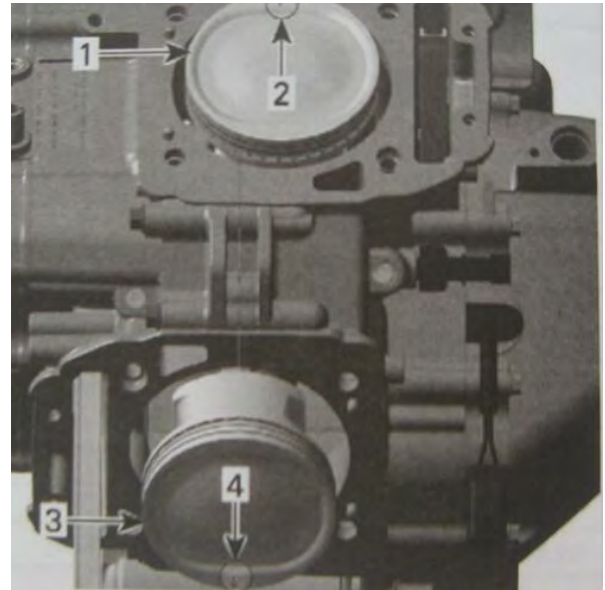

PISTON RINGS

Ring Removal

Remove:

- cylinder head
- cylinder
- piston pin.

Ring Inspection

Ring/piston Groove Clearance

1. Piston
2. Feeler gauge

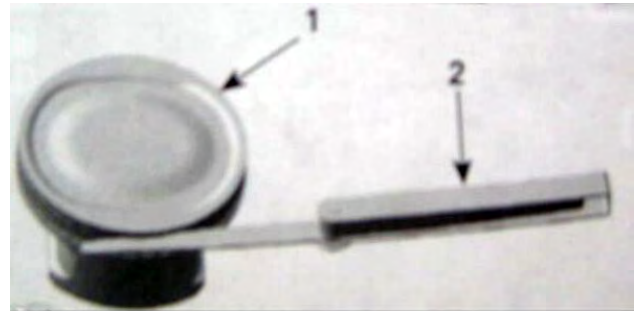

Using a feeler gauge measure each ring/piston groove clearance. If the clearance is too large, the piston and the piston rings should be replaced.

Ring/piston groove clearance	
Upper compression ring	
New	0.030 to 0.070 mm
Service limit	0.150 mm
Lower compression ring	
New	0.020 to 0.060 mm
Service limit	0.150 mm
Oil scraper ring	
New	0.010 to 0.045 mm
Service limit	0.150 mm

Ring end gap	
Upper compression ring	
New	0.25 to 0.40 mm
Service limit	1.50 mm
Lower compression ring	
New	0.35 to 0.50 mm
Service limit	1.50 mm
Oil scraper ring	
New	0.20 to 0.80 mm
Service limit	1.50 mm

To measure the ring end gap place the ring in the cylinder in the area of 8 to 16 mm from top of cylinder.

NOTE: In order to correctly position the ring in the cylinder, use piston as a pusher.

Using a feeler gauge, check ring end gap. Replace ring if gap exceeds above described specified tolerance.

Ring Installation

For installation, reverse the removal procedure. Pay attention to the following details.

NOTE: First install spring and then rings of oil scraper ring. Install the oil scraper ring first, then the lower compression ring with the word “N and TOP” facing up, then the upper compression ring with the word “N and TOP” facing up.

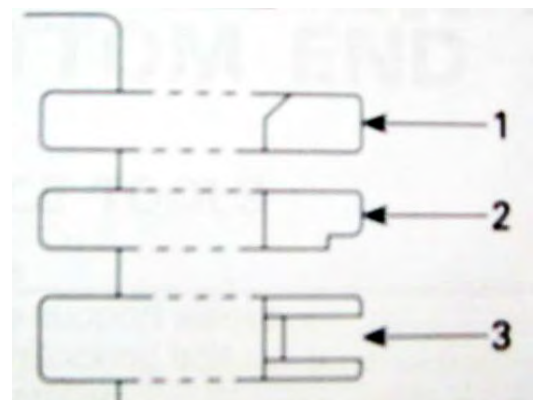

1. Upper compression ring
2. Lower compression ring
3. Oil scraper

CAUTION: Ensure that top and second rings are not interchanged.

NOTE: Use a ring expander to prevent breakage during installation. The oil ring must be installed by hand.

Check that rings rotate smoothly after installation. Space the piston ring end gaps 120° apart and do not align the gaps with the piston pin bore or the thrust side axis.

1. DO NOT align gap with piston thrust side axis
2. DO NOT align ring with piston pin bore axis
- A. 120°.

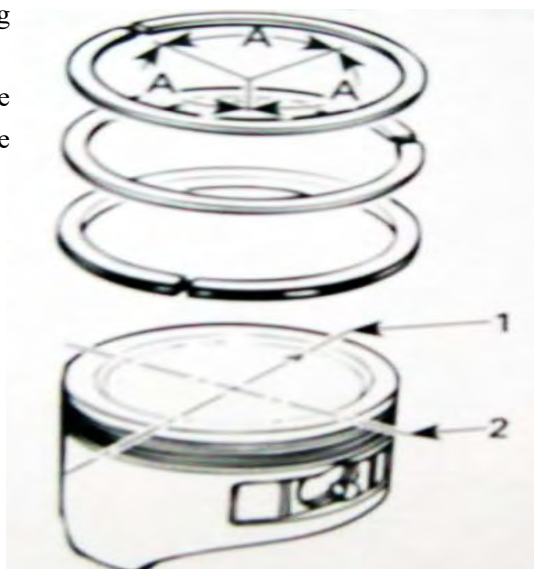

DRIVE SHAFT

Oil Seal Removal

To remove the front oil seal, no need to remove the engine. Lift the front of vehicle to avoid engine oil spillage. Separate the front propeller shaft from engine.

For the rear oil seal the gearbox removal is necessary.

Engine Drive Shaft Removal

NOTE: The engine drive shaft is located inside the engine and comes through it to drive the front differential.

Separate gearbox from engine.

To the rear of engine, remove the bearing cover and its O-ring.

1. bearing cover
2. o-ring

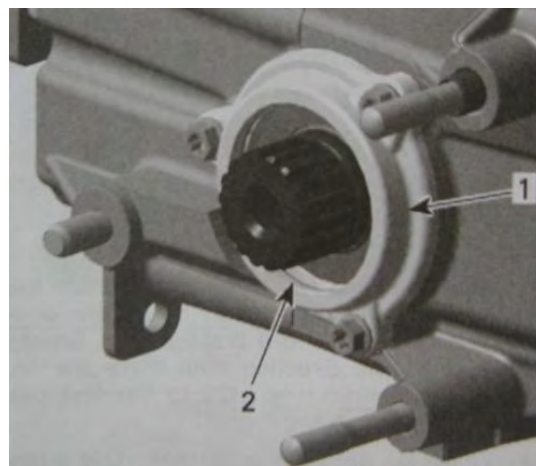

Pull out drive shaft.

CAUTION: check ends of the circlip for sharp edges or burr before removing the drive shaft, to avoid damaging the oil seal.

1. bearing cover gearbox side
2. drive shaft
3. circlip

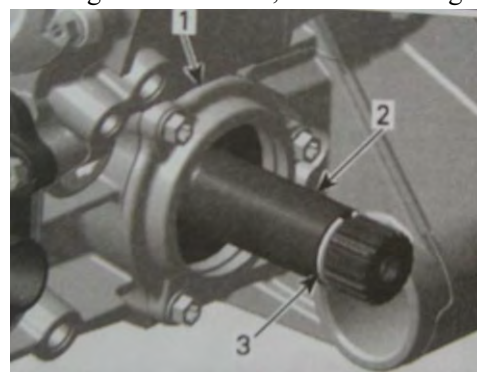

Remove the other bearing cover at the front of engine.

Engine Drive Shaft Inspection

Replace oil seals and/or O-ring if they are brittle, hard or damaged.

Check drive shaft bearings for contamination and/or metal shavings. Check if bearings turn freely and smoothly. Replace if necessary.

Check drive shaft for cracks, bend, pitting or other visible damages.

Check drive shaft splines for wear or damages.

Check oil seal running surface of the drive shaft for scratches. Replace if necessary.

Engine Drive Shaft Installation

The installation is reverse of removal procedure. Pay attention to the following details.

Clean all metal components in a solvent.

Crankcase surface and bearing covers are best cleaned using a combination of LOCTITE chisel and a brass brush. Brush a first pass in one direction then make the final brushing perpendicularly (90°) to the first pass cross (hatch).

CAUTION: Do not wipe with rags. Use a new clean hand towel only.

Then install drive shaft oils with the oil seal installer.

Use a suitable installer for installing bearings. Use LOCTITE 5910 on mating surfaces.

IMPORTANT: When beginning the application of the bearing cover sealant, the assembly and the first torquing should be done within 10 minutes. It is suggested to have you need on hand to save time.

Use a plexiglass plate and apply some sealant on it. Use a soft rubber roller (50-75 mm) available in arts products suppliers for printing, and roll the sealant to get a thin uniform coat on the plate (spread as necessary). When ready, apply the sealant on bearing cover surfaces.

Do not apply in excess as it will spread out inside crankcase.

NOTE: It is recommended to apply this specific sealant as described here to get a uniform application without lumps. If you do not use the roller method, you may use your finger to uniformly distribute the sealant (using a finger will not affect the adhesion).

To install bearing cover no. 6, fit oil seal protection sleeve into oil seal.

1. Protection sleeve
2. Bearing cover
3. O-ring
4. Drive shaft

Install bearing cover then place O-ring inside cover.

Finally check for axial play of the drive shaft.

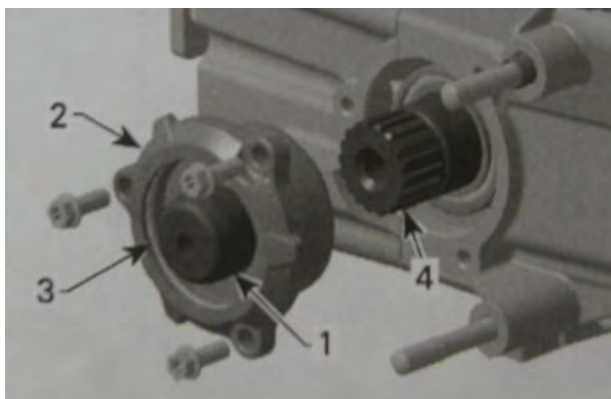
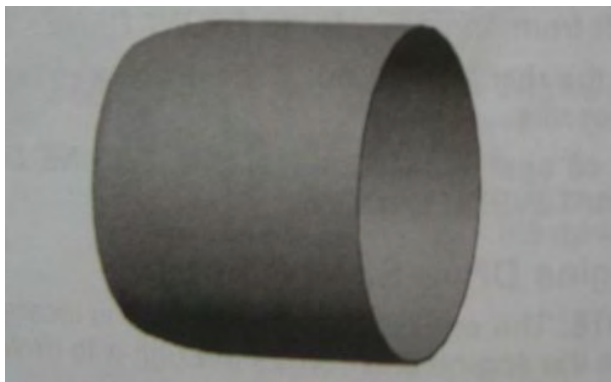

PTO COVER

Cover Removal

Remove

- CVT and air guide. Refer to TRANSMISSION
- Disconnect vent hose
- PTO cover screws and pull PTO cover.

1. PTO cover
2. PTO cover screws
3. vent hose nipple



Cover Inspection

Check the PTO cover for cracks or other damage.
Replace PTO cover if damaged.

Clean oil breather bore in PTO cover from contaminations with part cleaner then use an air gun to dry it.

1. oil breather bore



Check oil seal running surface of crankshaft PTO side for grooves. Replace if necessary.

Oil Seal Installation

The installation is the reverse of the removal procedure.

Pay attention to the following details.

CAUTION: Oil seal must be installed with sealing lip toward the engine.

Push oil seal in place by using the oil seal installer.

1. PTO cover
2. oil seal
3. oil seal installer

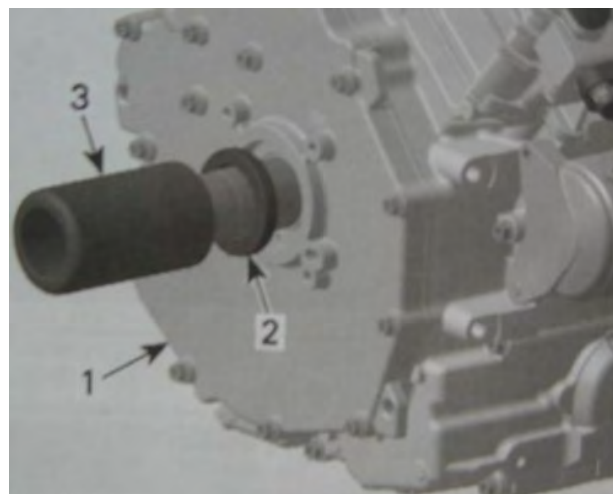

Check plain bearings for scorings or other damages.
NOTE: Measure plain bearing inside diameter and compare to crankshaft journal diameter (PTO support bearing). Refer to CRANKSHAFT in this section. Replace if the measurement is out of specification.

1. plain bearing
2. oil bore
- A. measure plain bearing inside diameter

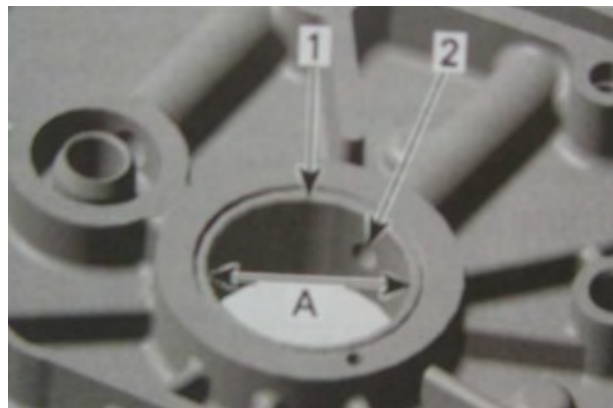

Plain bearing inside diameter (PTO side support bearing)	
Service limit	34.080 mm

Plain Bearing Replacement Procedure

Plain Bearing Removal

Carefully remove the oil seal **no. 9** with a screwdriver, without damaging the PTO cover.

Push-out the plain bearings from the outside towards the inside using the plain bearing remover/installer.

The PTO cover has to be supported from below with suitable support with straight surface, in order to prevent damage of the sealing surface.

1. PTO cover
2. plain bearing remover/installer

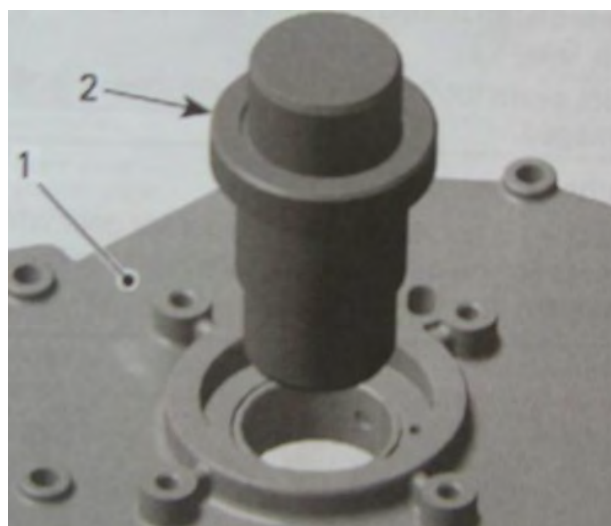

Plain Bearing Installation

CAUTION: Unless otherwise instructed, never use hammer to install plain bearings. Use press only.

Install plain bearings with the proper plain bearing remover/installer in a cool PTO cover. Do not lubricate plain bearings and/or PTO cover for installation.

Carefully press-in the plain bearings in the same direction as during disassembly, from the outside towards the inside. Support PTO cover with suitable support with straight surface, in order to prevent damage of the sealing surface.

CAUTION: Mark position of oil bore on PTO cover and on plain bearing remover/installer. Align mark on plain bearing remover/installer with mark on PTO cover.

1. mark position of oil bore on PTO cover
2. mark position of oil bore on plain bearing remover/installer



NOTE: Wrong oil bore position will stop oil supply to plain bearings and will damage the engine.

CAUTION: The partition of the plain bearings must be positioned near to oil bore in counterclockwise direction (refer to no.3 in next illustration).

1. PTO cover (inside)
2. partition
3. oil bore

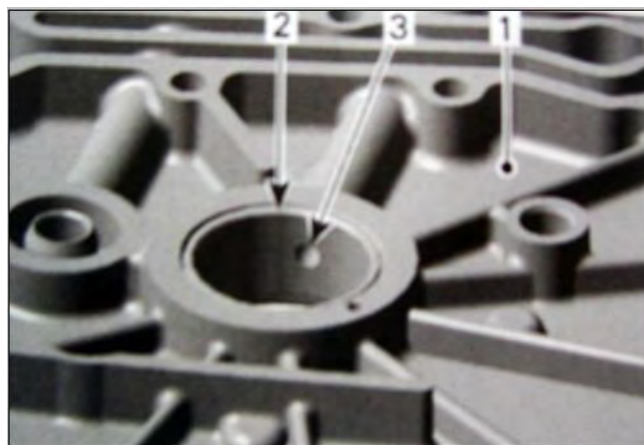

Cover Installation

For installation, reverse the removal procedure.

Pay attention to the following details.

NOTE: At installation, replace PTO cover gasket and oil seal.

Tightening sequence for screws on PTO cover is as per following illustration.



DRIVE GEARS

The drive gears are located on the engine PTO side behind the PTO cover.

1. intermediate gear
2. oil pump gear
3. water pump gear
4. breather gear

Drive Gear Removal

Remove:

- PTO cover (refer to PTO COVER)
- Intermediate gear
- Oil pump gear
- Water pump gear

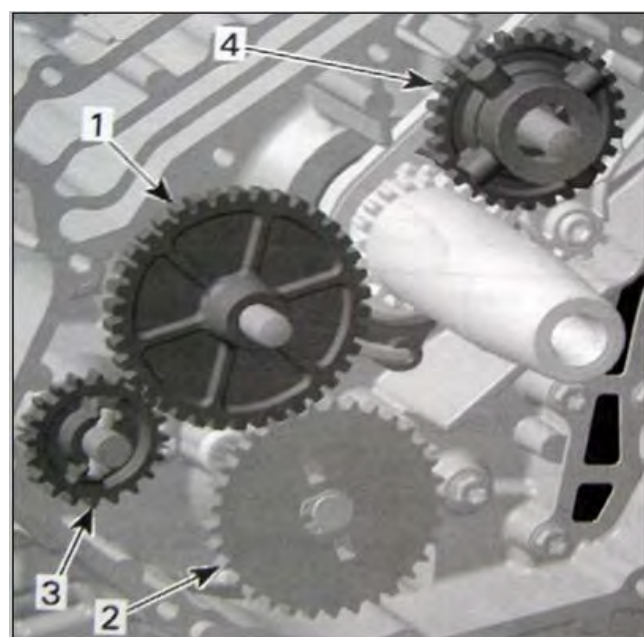

To remove water pump gear, pull the shaft assembly a bit out and turn it about one teeth until it stays out.

Now you can push water pump gear down. Remove needle pin and pull water pump gear out.

Remove breathe gear.

Drive Gear Inspection

Intermediate Gear/Oil Pump Gear/Water Pump Gear. Inspect gears for wear or other damage. Replace if damaged.

Breather Gear

The engine is equipped with a breather gear which prevents engine oil coming out through the breathing system into the air box.

1. breather gear
2. V-ring

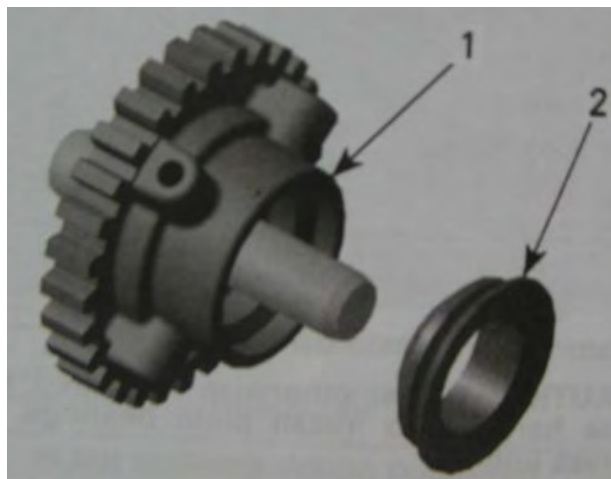

Inspect gear for wear or other damage.

Check ball bearing for excessive play and smooth operation. Replace breather gear assembly if necessary.

Drive Gear Installation

The installation is essentially the reverse of the removal procedure, but pay attention to the following details.

NOTE: At installation replace the V-ring no. 16 of the breather gear.

Adequately oil the ball bearing of the breather gear.

TIMING CHAIN

The engine is equipped with two timing chains. One of the timing chains is located on engine MAG side behind the magnet cover. The second timing chain is located on engine PTO side behind the PTO cover.

Removal of Magneto Side Timing Chain

Remove:

- valve cover, chain tensioner and camshaft timing gear (refer to CYLINDER AND HEAD)
- magneto cover and rotor (refer to MAGNETO SYSTEM)
- timing chain guide and lower timing chain guide.

1. Timing chain
2. Timing chain guide
3. Lower timing chain guide

Carefully pull the timing chain sideward and down from the crankcase.

NOTE: Mark the operating direction of the timing chain before removal.

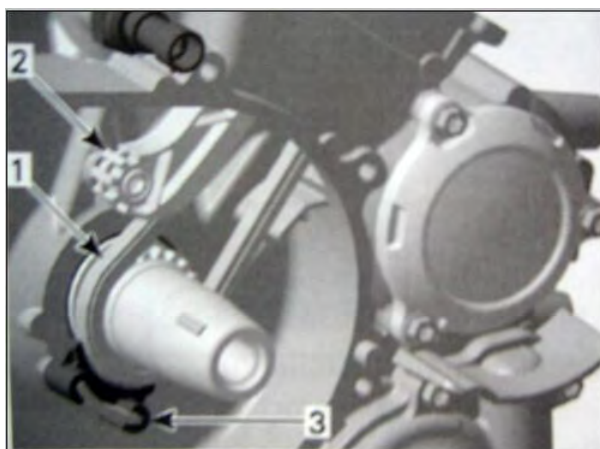

Removal of PTO Side Timing Chain

Remove:

- valve cover, chain tensioner and camshaft timing gear (refer to CYLINDER AND HEAD section)
- PTO cover (refer to PTO COVER)
- Intermediate gear and breather gear (refer to DRIVE GEARS)
- Timing chain guide and lower timing chain guide (see illustration above).

Carefully pull the timing chain sideward and down from the crankcase.

NOTE: Mark the operating direction of the timing chain before removal.

Timing Chain Inspection

Inspection is the same for both timing chains.

NOTE: Check timing chain on camshaft timing gear for excessive radial play.

Check chain condition for wear and teeth condition.

If chain is excessively worn or damaged, replace it as a set (camshaft timing gear and timing chain).

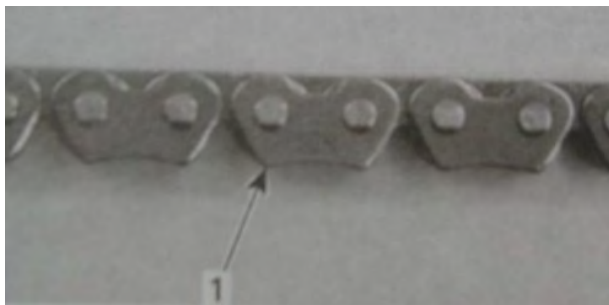

Timing Chain Installation

Installation is the same for both timing chains.

The installation is essentially the reverse of the removal procedure, but pay attention to the following details.

NOTE: Ensure to perform proper valve timing. Lock crankshaft (see CRANKSHAFT) and camshaft at TDC ignition (refer to CYLINDER AND HEAD section).

Install timing chain with camshaft timing gear then, adjust chain tension (refer to CYLINDER AND HEAD section).

CAUTION: Improper valve timing will damage engine components.

CRANKCASE

Crankcase Disassembly

Remove:

- drive shaft (refer to ENGINE DRIVE SHAFT)
- PTO cover (refer to PTO COVER)
- Drive gears (refer to DRIVE GEARS)

NOTE: Oil pump removal from crankcase is not necessary, but recommended to see condition of oil pump (refer to LUBRICATION SYSTEM section).

- electric starter

1. electric starter

2. screw

- magneto cover and rotor (refer to MAGNETO SYSTEM section)

- electric starter drive gears (refer to MAGNETO SYSTEM section)

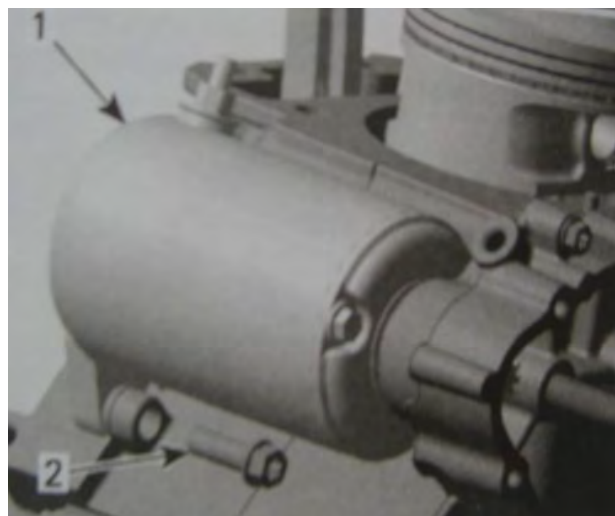

- water pump housing (refer to COOLING SYSTEM section)
- oil filter (refer to LUBRICATION SYSTEM section)
- cylinder head and cylinder (refer to CYLINDER AND CYLINDER HEAD section)
- timing chains and timing chain guides (refer to TIMING CHAIN and TIMING CHAIN GUIDE).

Remove retaining screws of crankcase.

- 1. 4 screws M8 x 65
- 2. 12 screws M6 x 75
- 3. 1 screw M6 x 35

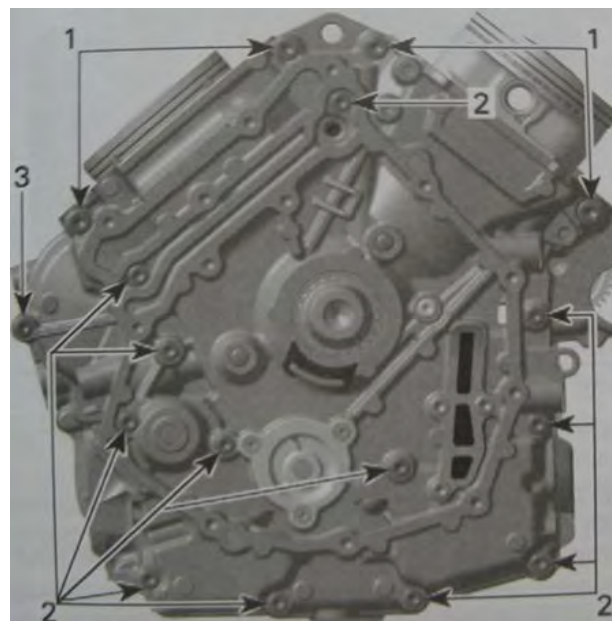

Carefully split crankcase halves by using a screw driver and a soft hammer.

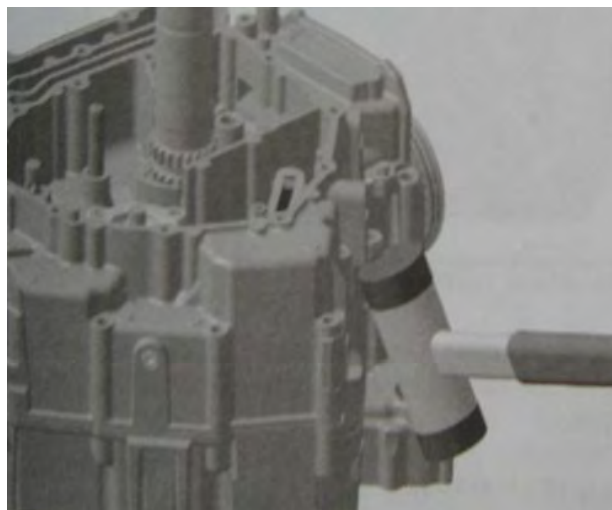

NOTE: During disassembly, do not damage the sealing surfaces of the crankcase halves.

Pull crankshaft out of crankcase.

Remove the water pump intermediate shaft and the water pump gear.

- 1. water pump intermediate shaft
- 2. water pump gear

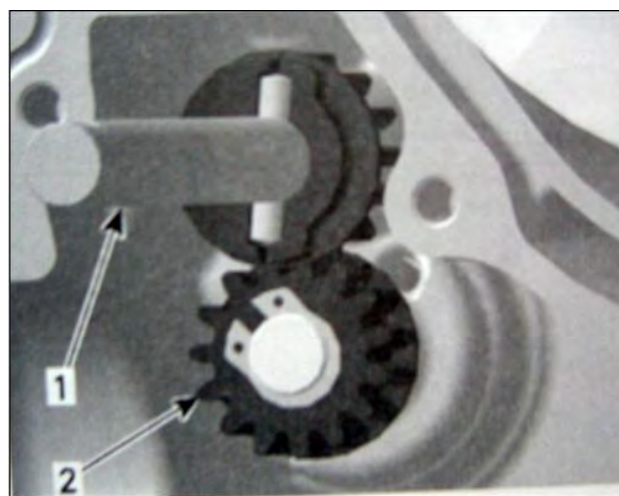

Remove engine oil strainer.

1. engine oil strainer
2. retaining plate
3. screws

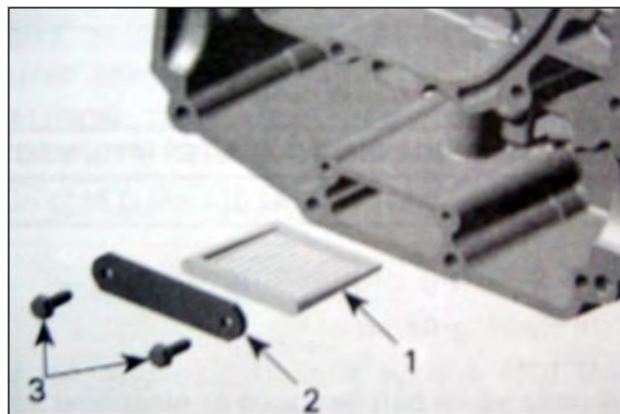

Crankcase Inspection

NOTE: Remove all remaining parts from the crankcase halves; they could get damaged during repair work.

Clean crankcase halves from contaminations and blow the oil supply lines with compressed air.

Check crankcase halves for cracks or other damage.

Replace if damaged.

Check plain bearings no. 17 and no.18 for scorings or other damages.

NOTE: Measure plain bearing inside diameter and compare to PTO/MAG side journal diameters of crankshaft (refer to *CRANKSHAFT*). Replace if the measurements are out of specification.

1. plain bearing
2. oil bore
- A. measure plain bearing inside diameter

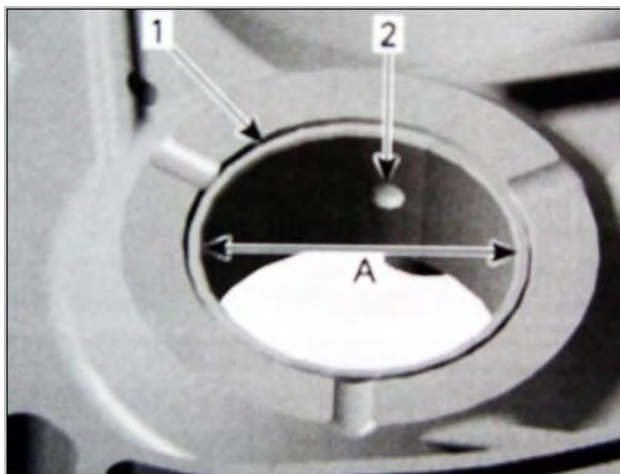

plain bearing inside diameter	
service limit	42.070 mm

Plain Bearing Replacement

Plain bearing Removal

CAUTION: Always support crankcase halves properly when ball bearing or plain bearings are removed. Damages to crankcase halves may occur if this procedure is not performed correctly.

NOTE: Always use a press for removal of plain bearings.

Remove plain bearings with the proper plain bearing remover/installer.

Carefully push the plain bearings out, from the crankcase half inside towards the outside.

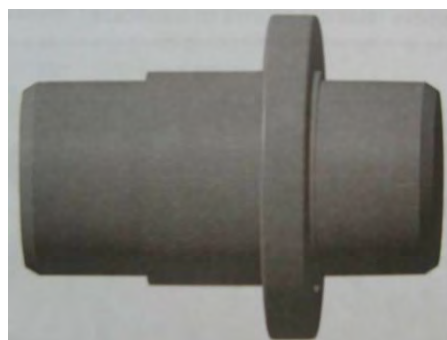

NOTE: Place the proper crankcase support sleeve under crankcase halves before removing plain bearings. During disassembly, make sure not to damage the surfaces of the crankcase halves.

1. Crankcase half
2. Plain bear remover/installer
3. Crankcase support sleeve

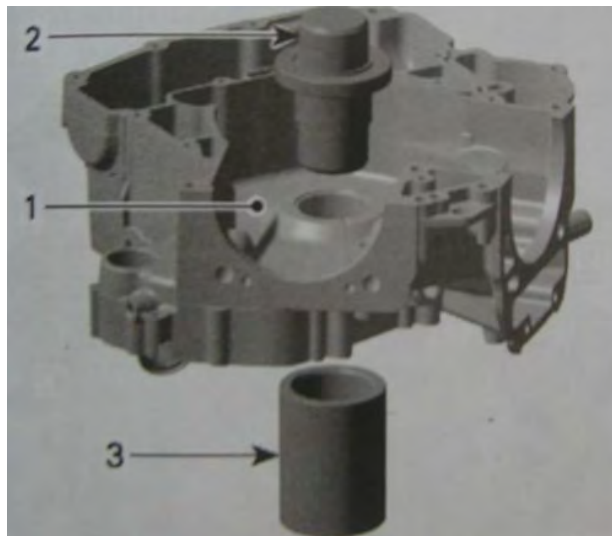

Plain Bearing Installation

CAUTION: Unless otherwise, instructed, never use hammer to install ball bearings or plain bearings. Use press only.

Install plain bearings with the proper plain bearing remover/installer in a cool crankcase. Do not lubricate plain bearings and/or crankcase for installation.

NOTE: Place the proper crankcase support sleeve under crankcase halves before installing the plain bearings.

Carefully press-in the plain bearings in the same direction as during disassembly, from the crankcase inside toward the outside.

During reassembly, make sure not to damage the sealing surface of the crankcase halves.

CAUTION: Mark position of oil bore on crankcase half and on plain bearing remover/installer. Align mark on plain bearing remover/installer with mark on crankcase half.

1. oil bore position marked on crankcase
2. oil bore position marked on plain bearing remover/installer

NOTE: Wrong oil bore position will stop oil supply to plain bearings and will cause engine damage.

CAUTION: the partition of the plain bearings in crankcase half MAG side must be positioned near to oil bore in clockwise direction (refer to no. 3 in next illustration).

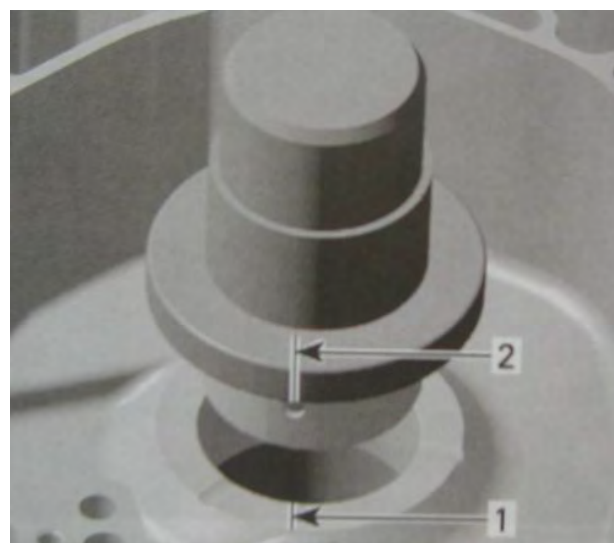

CAUTION: The partition of the plain bearings in crankcase half PTO side must be positioned near to oil bore in counterclockwise direction (refer to no. 3 in next illustration).

1. crankcase half PTO (inside)
2. oil bore
3. partition

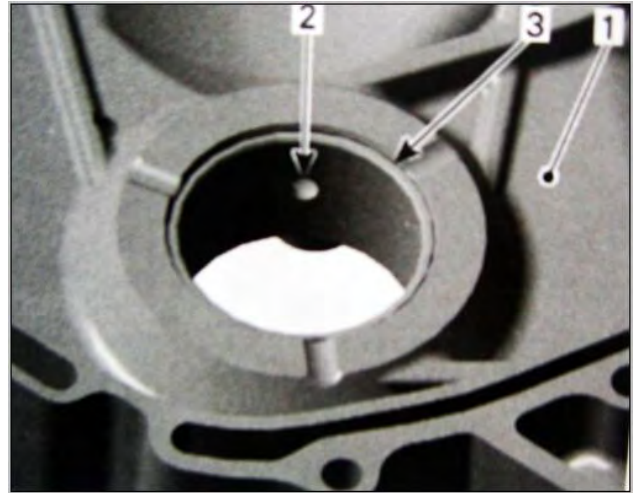

NOTE: Use an O-ring ($\phi 42 \times 1$ or 1.5 mm thickness) to hold plain bearings in place during installation. The O-ring will disappear in the groove, of the plain bearing remover/installer.

Crankcase Assembly

The assembly of crankcase is essentially the reverse of removal procedure. However, pay attention to the following details.

NOTE: Clean oil passages and make sure they are not clogged.

Clean all metal components in a solvent.

At installation, replace crankcase gasket.

Oil the plain bearings before mounting the crankshaft.

CAUTION: Correctly reinstall crankshaft (refer to CRANKSHAFT).

Reinstall engine oil strainer.

Reinstall water pump shaft shafts /gears.

Tightening sequence for screws on crankcase is as per following illustration.

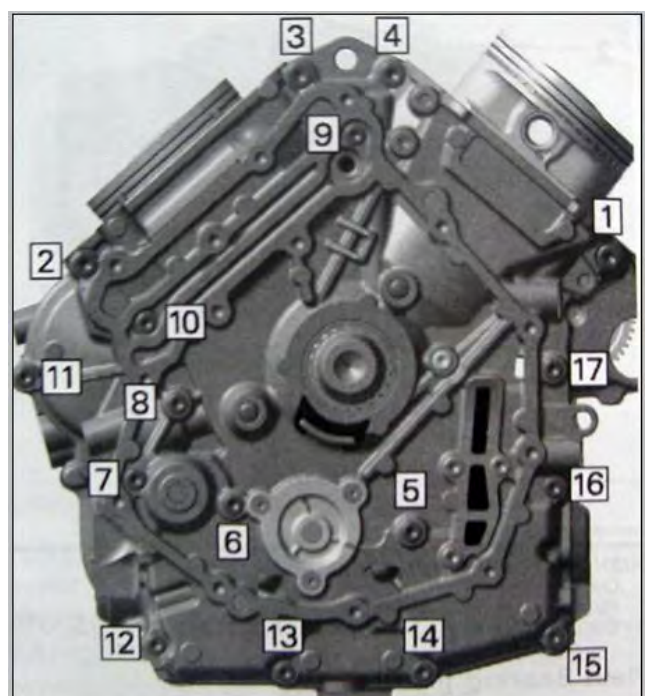

CRANKSHAFT

Crankshaft Removal

Refer to CRANCASE.

Crankshaft Inspection

NOTE: Check each bearing journal of crankshaft for scoring, scuffing, cracks or other signs of wear.

NOTE: Replace crankshaft if the gears are worn or otherwise damaged.

CAUTION: Components with less than the service limit always have to be replaced. If this is not observed, severe damage may be caused to the engine.

1. Crankshaft timing gears



Connecting Rod Big End Axial Play

Using a feeler gauge, measure distance between butting face of connecting rods and crankshaft counterweight. If the distance exceeds specified tolerance, replace the crankshaft.

1. Crankshaft
2. Connecting rods
3. Feeler gauge

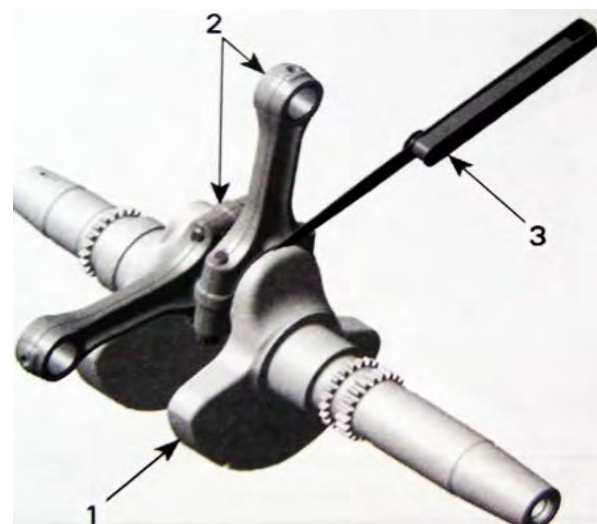

Connecting rod big end axial play	
New	0.200 to 0.500 mm
Service limit	0.6 mm

Connecting Rod/Piston Pin Clearance

NOTE: Prior to remove connecting rod from crankshaft, mark big end halves together to ensure a correct reinstallation (cracked surface fits in only one position).

Remove connecting rods from crankshaft.

CAUTION: Always replace connecting rod screws no. 19 if removing the connecting rod. It is recommended to replace plain bearings no. 20, in case of installing the connecting rod.

1. Connecting rod screws.



Measure crankpin Compare to inside diameter of connecting rod big end.

1. Micrometer
2. Crankpin area for plain bearing

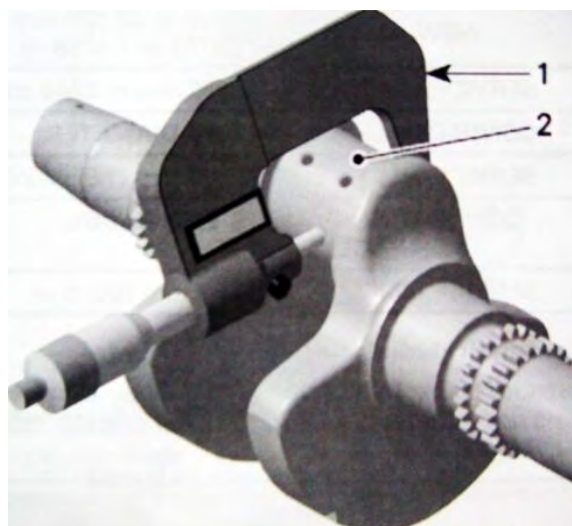

To measure the rod big end diameter, use the OLD screws .

Install the OLD plain bearings as they were mounted initially.

Do the torque procedure as described further.



Crankshaft pin diameter	
new	40.009 to 40.025 mm
Service limit	39.990 mm
Connecting rod big end diameter	
Service limit	40.100 mm
Connecting rod big end radial clearance	
Service limit	0.09 mm

Crankshaft Radial Play MAG/PTO Side

Measure crankshaft on MAG/PTO side. Compare to inside diameter of MAG/PTO plain bearing (refer to CRANKCASE).

1. Micrometer
2. Crankshaft area for MAG plain bearing

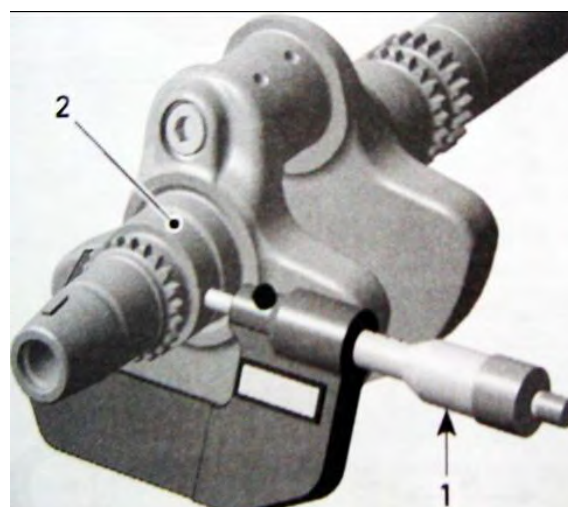

1. Micrometer
2. Crankshaft area for PTO plain bearing

Crankshaft main journal diameter	
New	42.024 to 42.040 mm
Service limit	42.000 mm
Crankshaft deflection	
Service limit	0.07mm
Crankshaft radial clearance	
Service limit	0.06 mm

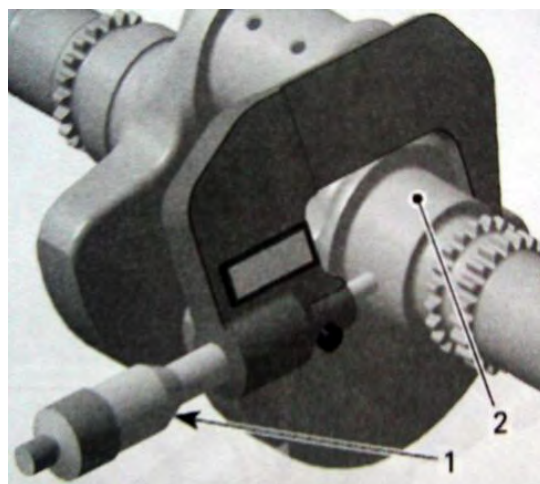

**Crankshaft Radial Play
(PTO side support bearing)**

Measure crankshaft journal of PTO support bearing. Compare to inside diameter of PTO support bearing in PTO cover (refer to PTO COVER).

Crankshaft pin journal diameter (PTO support bearing)	
new	34.024 to 34.040 mm
Service limit	34.010mm
Crankshaft PTO support bearing radial clearance	
Service limit	0.01 mm

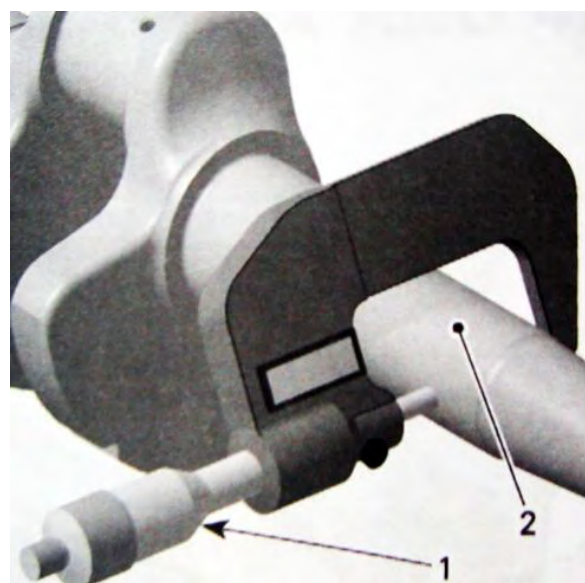

Crankshaft Assembly

For assembly, reverse the disassembly procedure.

Pay attention to following details.

NOTE: Use **NEW** plain bearings **no. 20**, when connecting rod big end diameter is out of specification.

Put plain bearings correctly in place and clean the split surface on both sides (cracked area) carefully with compressed air.

1. Half plain bearing of connecting rod big end
2. Split surface of the connecting rod
3. Nose of plain bearing in line with connecting rod groove



NOTE: Oil the plain bearing surface of the connecting rod and crank pin before installation.

Torque NEW connecting rod screws as per following procedure:

First, install screws with half of the recommended torque. Do not apply any thread locker.

Secondly, torque connecting rod screws to 20 N.m.

Finish tightening the screws with an additional 60° turn using an angle torque wrench.

CAUTION: failure to strictly follow this procedure may cause screw to loosen and lead to engine damage. The plain bearing tapered end must be against the counterweight. Besides, as the “crankpin” has been stretched from the previous installation, it is very important to use a new screw at assembly.

The running direction of big end bearings and of the piston pins must not change.

Crankshaft Installation

For installation of crankshaft in crankcase reverse the removal procedure. Pay attention to the following details.

CAUTION: Observe the correct installation position when fitting the crankshaft with the connecting rods. The connecting rod MAG side has to face to cylinder 1.

OIL PRESSURE REGULATOR

The oil pressure regulator is located the engine magneto side (inside magneto cover).

1. Engine pressure regulator

NOTE: The oil pressure regulator system works when the oil pressure exceeds 450kPa (65ps).



Removal

Remove plug screw and pull oil pressure regulator out.

1. Plug screw
2. Gasket ring
3. Pressure regulator housing
4. Spring
5. Pressure regulator valve

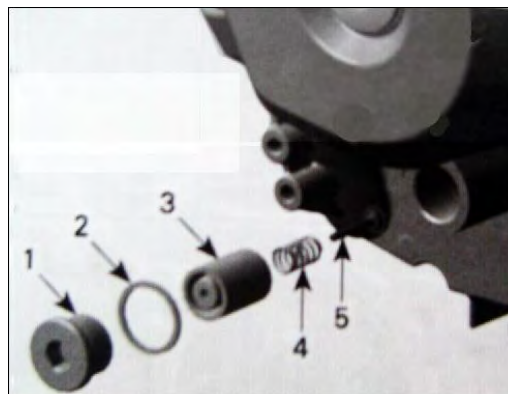

Inspection

Inspect pressure regulator hosing and valve for scoring or other damages.

Check spring for free length.

NOTE: Replace worn or damaged components.

Clean bore and thread in the magneto housing from metal shavings and other contaminations.

SPRING FREE LENGTH	
New nominal	39 mm(1.535 in)
Service limit	37 mm(1.457in)

Installation

For installation, reverse the removal procedure.

Pay attention to the following details.

NOTE: At installation, always replace the gasket ring no. 3 of the plug screw.

OIL PUMP

The oil pump is located on the engine PTO side (behind cover).

1. Oil pump

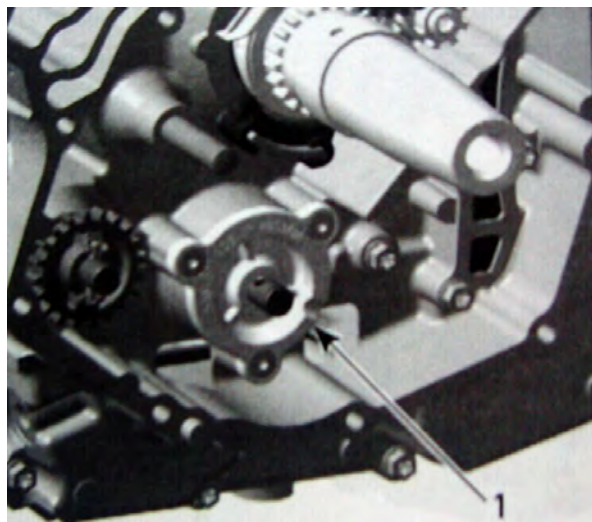
**Removal**

Remove parts to access the engine crankcase PTO cover.

Remove the engine crankcase PTO cover. .

Remove:

- retaining ring
- oil pump gear
- needle pin
- thrust washer
- oil pump cover screws and pull oil pump cover
- oil pump shaft with inner rotor and outer rotor.

1. Retaining ring
2. Oil pupm gear
3. Needle pin
4. Thrust washer

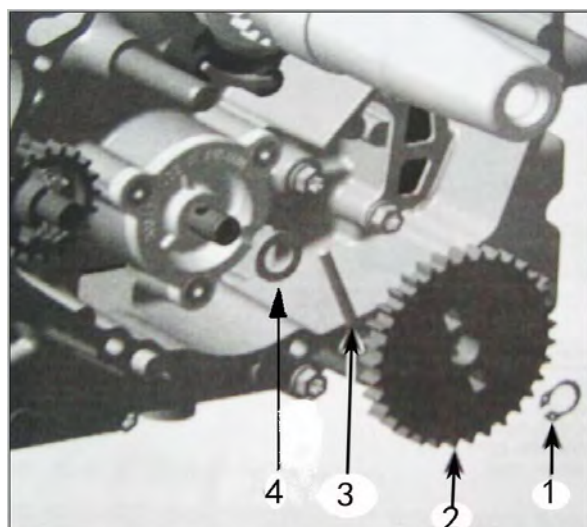

1. Retaining screws
2. Oil pump cover

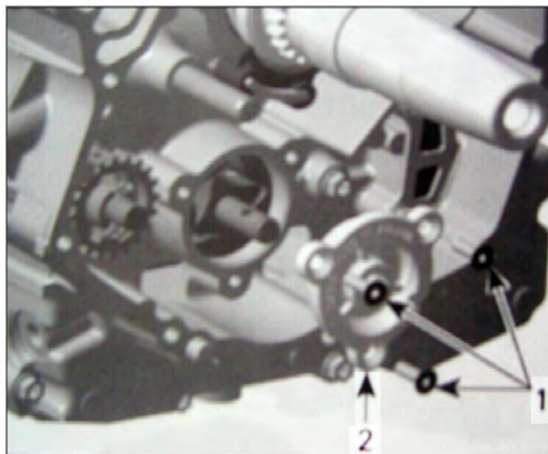

Inspection

Inspect oil pump for marks or other damages.
 Check for scratches in crankcase between outer rotor and oil pump bore. If so, replace damaged parts.

1. Oil pump bore
2. outer rotor
3. Oil pump shaft
4. Needle pin
5. Inner rotor

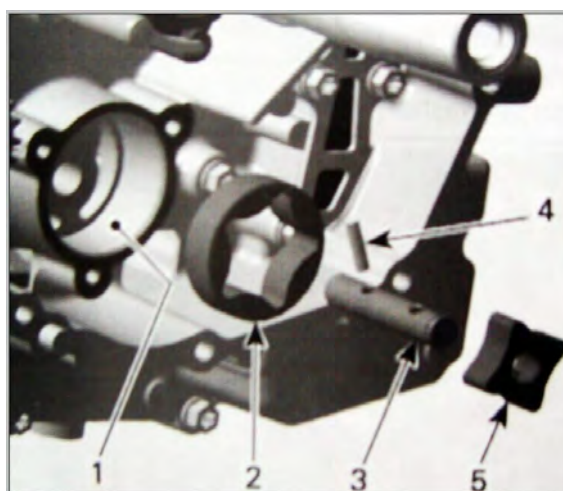

Check inner rotor for corrosion pin holes or other damages. If so, replace oil pump shaft assembly.

1. Pitting on the teeth

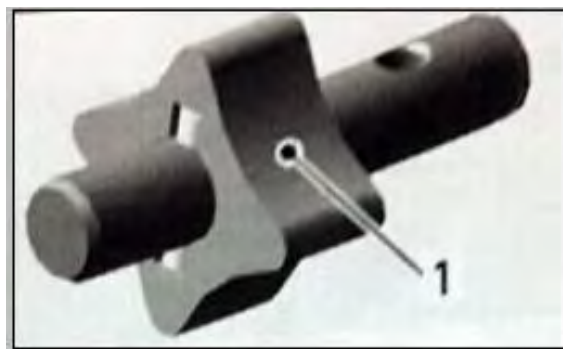

Using a feeler gauge, measure the clearance of inner and outer rotors as shown.

1. Outer rotor
 2. inner rotor
- A. SERVICE LIMIT:0.25mm(0.09in)**

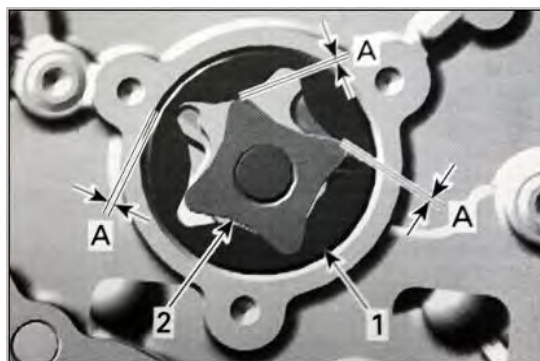

If clearance of inner and outer rotors exceeds the tolerance, replace oil pump shaft assembly. Ensure to also check oil pump cover. If damaged, replace the complete oil pump assembly.

If clearance between outer rotor and its bore in crankcase exceeds the tolerance, replace the complete oil pump assembly and/ or the crankcase.

Using a depth gauge, measure the axial clearance of the oil pump as shown..

Oil PUMP-MEASUREMENT "A"



Oil PUMP COVER - MEASUREMENT "B"

Difference between measurements should not exceed 0.2 mm. if so, replace the complete oil pump assembly.

NOTE: When the axial clearance of the oil pump shaft assembly increases, the oil pressure decreases.

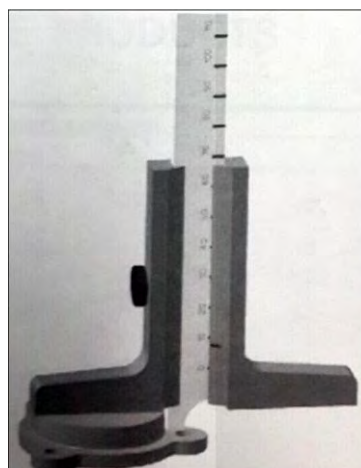

Installation

For installation, reverse the removal procedure.

Pay attention to the following details.

NOTE: The outer rotor and inner rotor are marked.

When installing, make sure both markings are on the upper side.

1. Markings

After reinstallation of the remaining parts, check for smooth operation of the oil pump assembly.

Final Test

After engine is completely reassembled, start engine and make sure oil pressure is within specifications .

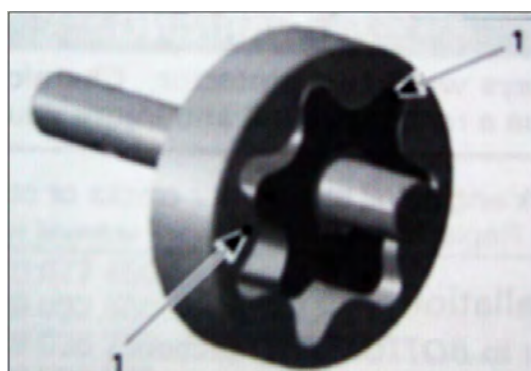

MAGNETO COVER

Magneto Cover Removal

Lock crankshaft at TDC.

Drain engine oil.

Disconnect crankshaft position sensor (CPS) connector and cut tie rap.

Remove magneto cover retaining screws.

1. magneto cover
2. retaining screws
3. crankshaft position sensor

Pull magneto cover.

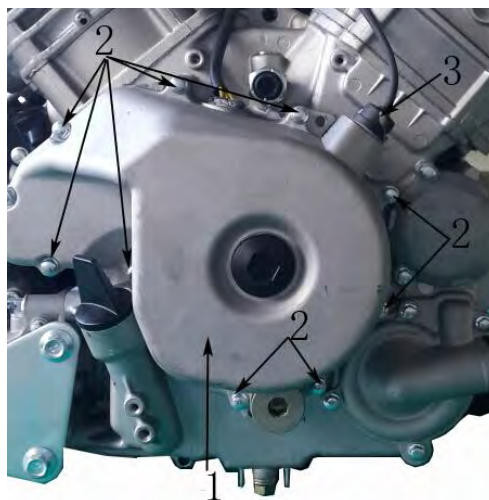

Magneto Cover Inspection and Cleaning

Check magneto cover for cracks or other damage. Replace if necessary.

Magneto Cover Installation

For installation, reverse the removal procedure.

However, pay attention to the following.

NOTE: At installation replace magneto cover gasket.

Apply Drei Bond sealing compound on stator cable grommet as shown in the illustration.

1. Apply drei bond sealing compound

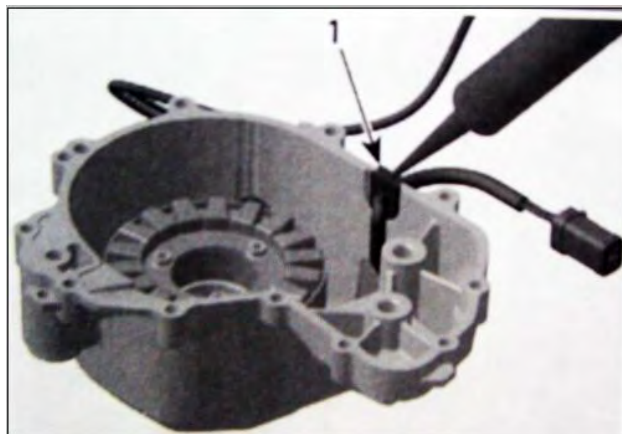

Tightening sequence for screws on magneto cover is as per following illustration.

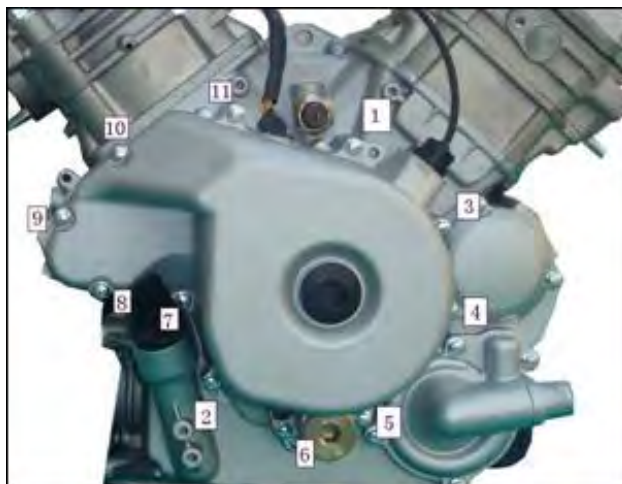

STATOR

Stator Removal

Remove magneto cover.

Remove screws securing holding strip.

Remove stator retaining screws then the stator.

1. Stator
2. Stator retaining screws
3. holding strip
4. holding strip screws



Stator Inspection

Check stator condition. If damaged replace it.

Check if stator wires are brittle, bard or otherwise damaged.

For electrical inspection, refer to CHARGING SYSTEM.

Stator Installation

For installation, reverse the removal procedure.

However, pay attention to the following.

CAUTION: When installing the stator take care that the cable is in place (guide for wire).

NOTE: There is only one position for the stator (notch in the magneto housing cover).

1. Threads for cable holding strip
2. Notch for stator

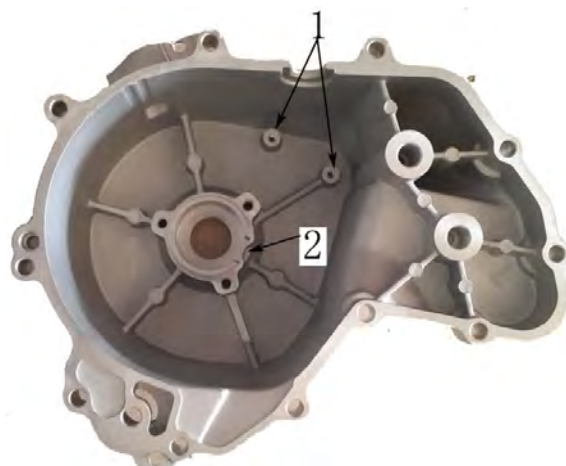

ROTOR

Rotor Removal

Lock crankshaft with crankshaft locking bolt.

Remove magneto cover. Refer to *MAGNETO COVER* above.

Remove screw and washer securing rotor to crankshaft.

1. Screw M16
2. Washer
3. Rotor

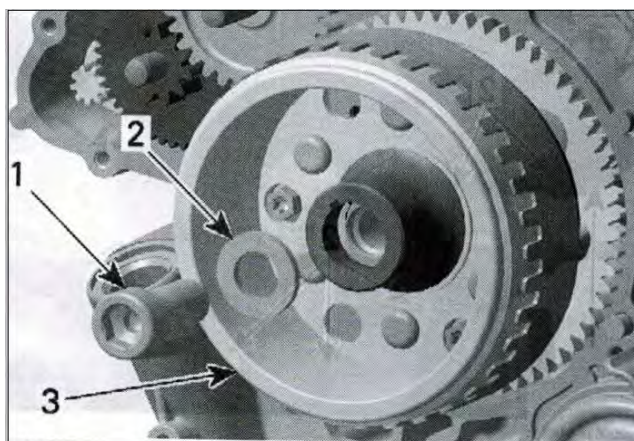

Install magneto puller and crankshaft then remove rotor.

NOTE: Use grease to place protector on crankshaft end prior to screw on the magneto puller.

1. Rotor
2. Magneto puller

Screw magneto puller bolt to remove rotor.



Rotor Inspection

Check inner side of rotor for scratches or other damage.

Check keyway of the rotor for wear or damages.

Check if trigger wheel teeth are bent or otherwise damaged.

1. Rotor with trigger wheel

Check woodruff and keyway on the crankshaft for wear or damages.

Replace parts as necessary.



Rotor Installation

For installation, reverse the removal procedure. However, pay attention to the following.

Clean crankshaft taper and rotor with pulley flange cleaner.

CAUTION: Taper on crankshaft and rotor must be free of grease.

Oil sprag clutch in sprag clutch housing and install sprag clutch gear.

1. Sprag clutch
2. Sprag clutch housing
3. Sprag clutch gear
4. Apply engine oil here

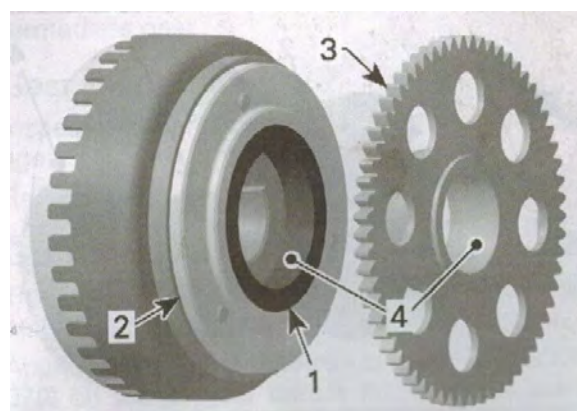

Slide rotor onto crankshaft. The woodruff key and the keyway must be aligned.

Rotate starter double gear counterclockwise to align intermediate gear teeth with sprag clutch gear.

1. Starter double gear
2. Sprag clutch gear
3. intermediate gear

SPRAG CLUTCH

Sprag Clutch Removal

Remove magneto cover

Loosen sprag clutch housing screws located inside rotor.

Remove rotor (refer to ROTOR above)

Remove sprag clutch gear.

Remove sprag clutch housing screws and sprag clutch housing.

1. Sprag clutch housing screws
2. Rotor
3. Sprag clutch
4. Sprag clutch housing

Sprag Clutch Inspection

Inspect sprag clutch and sprag clutch housing for wear and damage.

Also check the collar of the sprag clutch gear.

Perform a functional test of the sprag clutch. To do so, rotate sprag clutch gear in sprag clutch.

NOTE: Sprag clutch must lock in counterclockwise direction.

1. Lock

NOTE: Sprag clutch, housing and gear must be replaced at the same time, if damaged.

Sprag Clutch Installation

For installation, reverse the removal procedure. Pay attention to the following details.

Apply LOCTITE 648 (green) on threads of sprag clutch housing screws.

Install screw but do not torque yet.

Apply engine oil on sprag clutch and inside sprag clutch gear hole.

1. Sprag clutch
2. sprag clutch housing

Install rotor then torque sprag clutch housing screws to 30 N.m.

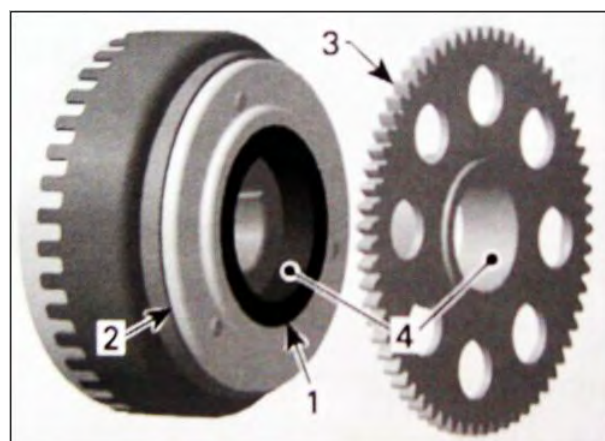
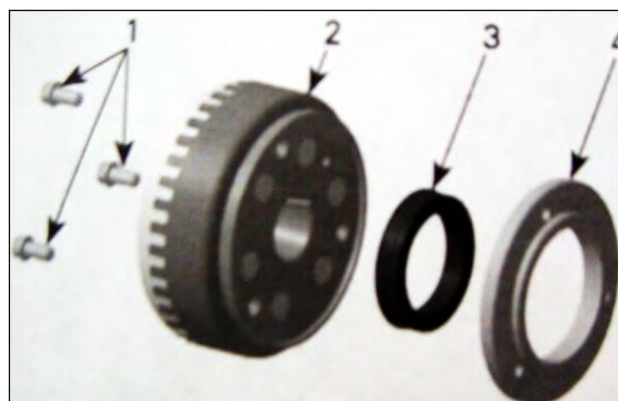
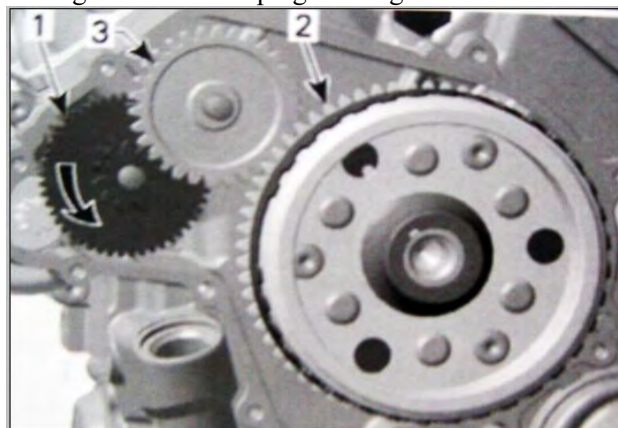

SPRAG CLUTCH GEAR

Sprag Clutch Gear removal

Remove rotor .

Pull sprag clutch gear from rotor.

1. Rotor
2. Sprag clutch gear

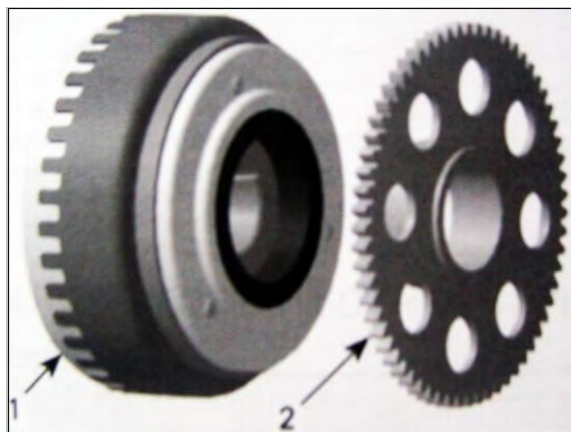

Sprag Clutch Gear Inspection

Inspect gear, especially teeth and sprag clutch collar, for wear and other damage.

Check needle bearing condition. Replace sprag clutch gear if necessary.

INSPECT

1. Teeth
2. Collar
3. Needle bearing

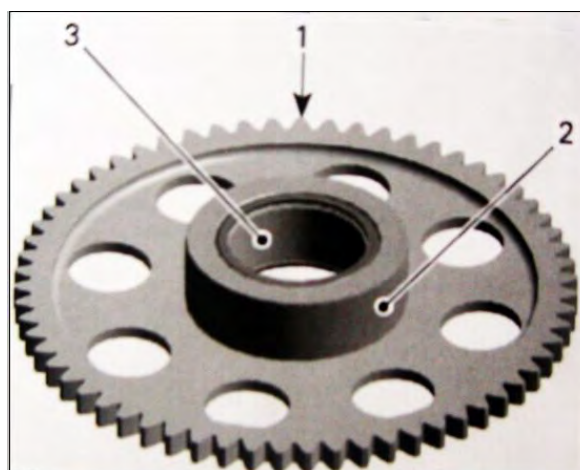

Sprag Clutch Gear Installation

The installation is the reverse of the removal procedure.

NOTE: Apply engine oil on needle bearing and collar of sprag clutch gear.

TRANSMISSION

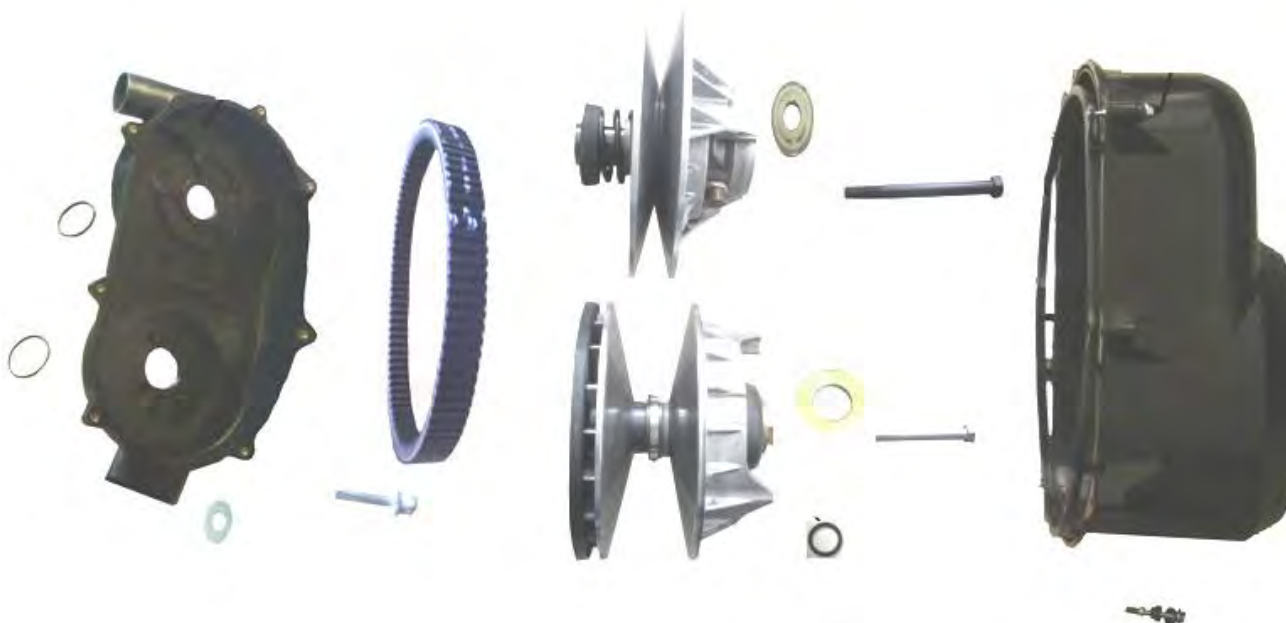

Never touch CVT while engine is running.

never drive vehicle when *variator* cover is removed.

Subcomponent installation and assembly tolerances require strict adherence to procedures detailed.

Never use any type of impact wrench at drive pulley removal and installation.

The clutch assembly is a precisely balanced unit. Never replace parts with used parts from another clutch assembly

These pulleys have metric threads. Do not SAE threads puller. Always tighten puller by hand to ensure that the drive pulley has the same type of threads prior to fully tightening.

DRIVE BELT

Removal

Remove:

- Distance screws
- remove *variator* cover and gasket.

1. *Variator cover*

2. *Distance screw*

3. *Gasket*

NOTE:

Remove the center top screw last. This screw allows to support the cover during removal.

Open driven pulley with the driven pulley expander.

Screw tool in the threaded hole of driven pulley and tighten to open the pulley.

1. *Driven pulley expander*

2. *Fixed sheave of driven pulley*

To remove belt, slip the belt over the edge of fixed sheave as shown.

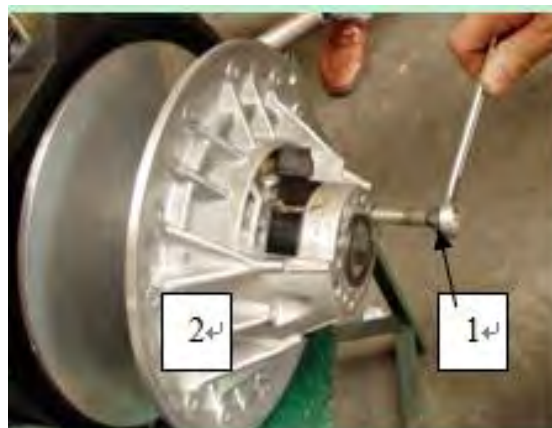

INSPECTION

Inspect belt for cracks, fraying or abnormal wear.
Replace if necessary.

Drive belt width	
Service limit	30.00mm(1.181 in)



Installation

For installation, reverse the removal procedure. Pay attention to following details.

1. Word printed on belt
2. Drive pulley (front)
3. Driven pulley (rear)
4. Rotation direction

The maximum drive belt life span is obtained when the drive belt has the proper rotation direction. Install it so that the arrow printed on belt is pointing towards front of the vehicle, viewed from top.

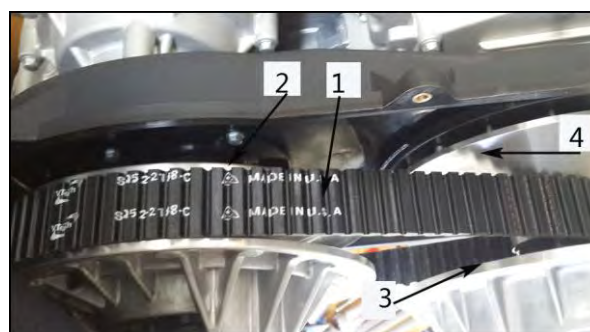

Install variator cover gasket.
Install the center top screw in first.
Tighten the distance screw as per following sequence.

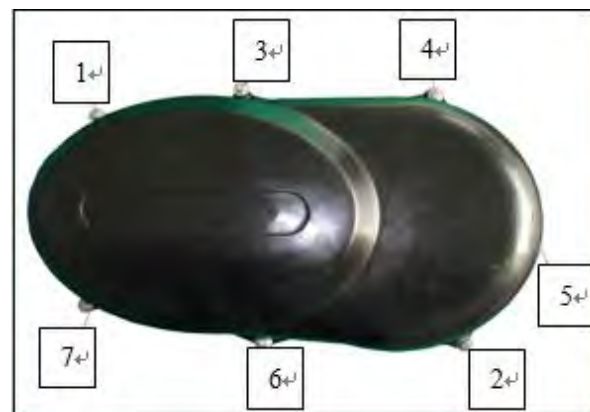

DRIVE PULLEY

1. Belt
2. Drive pulley
3. Driven pulley

Removal

- remove variator cover and gasket.
- Remove belt

Block the drive pulley as followed.

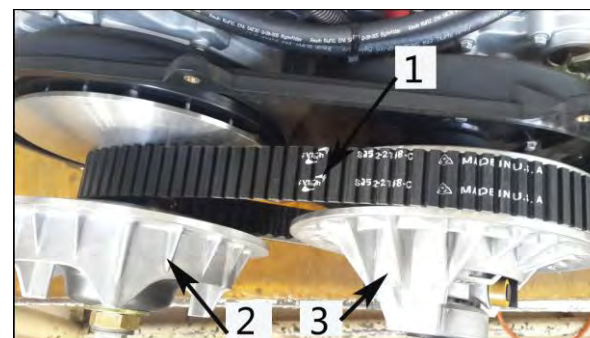

Block drive pulley with the pulley holding tool.

1. Pulley holding tool
2. Torque wrench



When the drive pulley is blocked, mark sliding sheave and governor cup to ensure correct reinstallation.

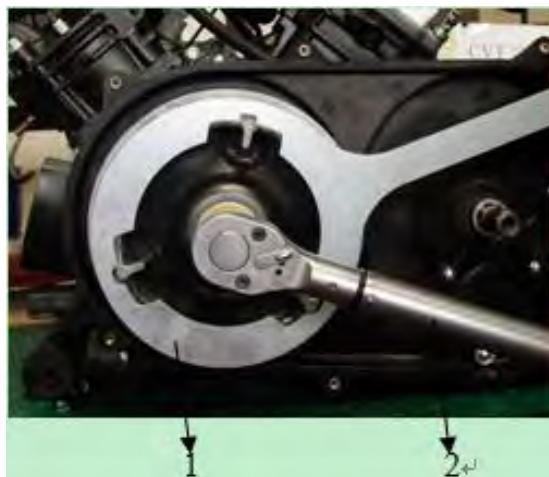

Unscrew the drive pulley screw (right hand thread), then remove it as well as the conical spring washer and thrust washer.

1. Drive pulley
2. Thrust washer
3. Drive pulley screw



Inspection

Drive pulley should be inspected annually for wear or damages.

Check drive pulley for cracks and sliding contact surface for excessive wear. Replace it if necessary.

Check one-way clutch bearing for excessive play and smooth operation. Replace one-way clutch if necessary.

Installation

For installation, reverse the removal procedure. Pay attention to the following details.

Do not apply any lubricant on crankshaft and drive pulley tapers.

Clean pulley faces and shaft with dry cloth.

Install drive pulley on crankshaft extension.

Do not forget to place thrust washer

Never substitute conical spring washer and/ or screw with jobber ones. Always use genuine parts for this

particular case.

Install thrust washer with its concave side towards drive pulley then install drive pulley screw.

To torque the drive pulley screw, block the drive pulley. Refer at the beginning of this section.

When the drive pulley is blocked, torque screw to 100N.m.

DRIVEN PULLEY

Removal

- remove *variator* cover and gasket.
- Remove belt



Using the pulley holding tool, hold the driven pulley during the removal of the driven pulley screw, do not remove screw completely.



Put in tow STUD to Driven Pulley

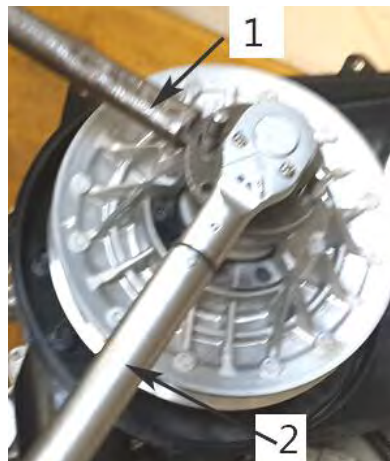

1. Driven Pulley holding tool
2. Torque wrench

When the driven pulley is blocked, unscrew the driven pulley screw.

1. *Driven pulley*
2. *Thrust washer*
3. *Driven pulley screw*



Inspection

Driven pulley should be inspected annually for wear or damages.

Check sliding and fixed sheave for cracks and sliding contact surface for excessive wear. Replace sliding sheave if necessary.

Check sliding sheave bushings for cracks, scratch and for free movement when assembled to sliding sheave.

Check ball bearing for free play and smooth operation. Replace if necessary.

Installation

For installation, reverse the removal procedure. Pay attention to the following details.

Chamfer on inside diameter of the spacer must face engine side.

Clean pulley faces and shaft with dry cloth.

Driven pulley is a spring loaded system.

Always place washer at the time of driven pulley installation.

When the driven pulley is blocked, torque screw to 60N.m.

CVT AIR GUIDE**Removal**

Remove:

- Variator cover
- Drive belt
- Drive pulley
- Driven pulley

Unscrew the clamps retaining the CVT air hoses
Remove CVT air guide.

Inspection

Clean CVT air guide from contamination.

Check O-rings if brittle, hard or damaged. Replace if necessary.

1. CVT air guide
2. O-rings

**Installation**

For installation, reverse the removal procedure.

GEARBOX

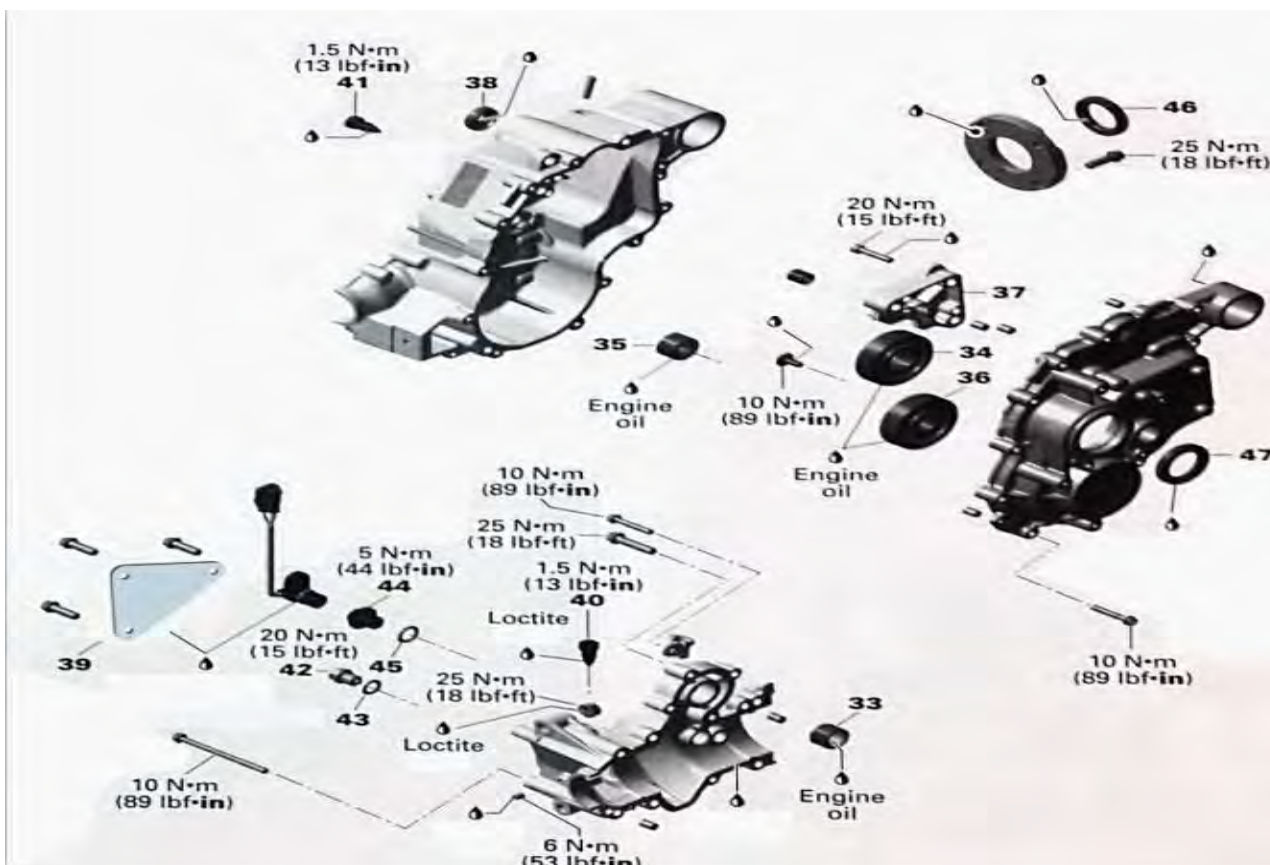
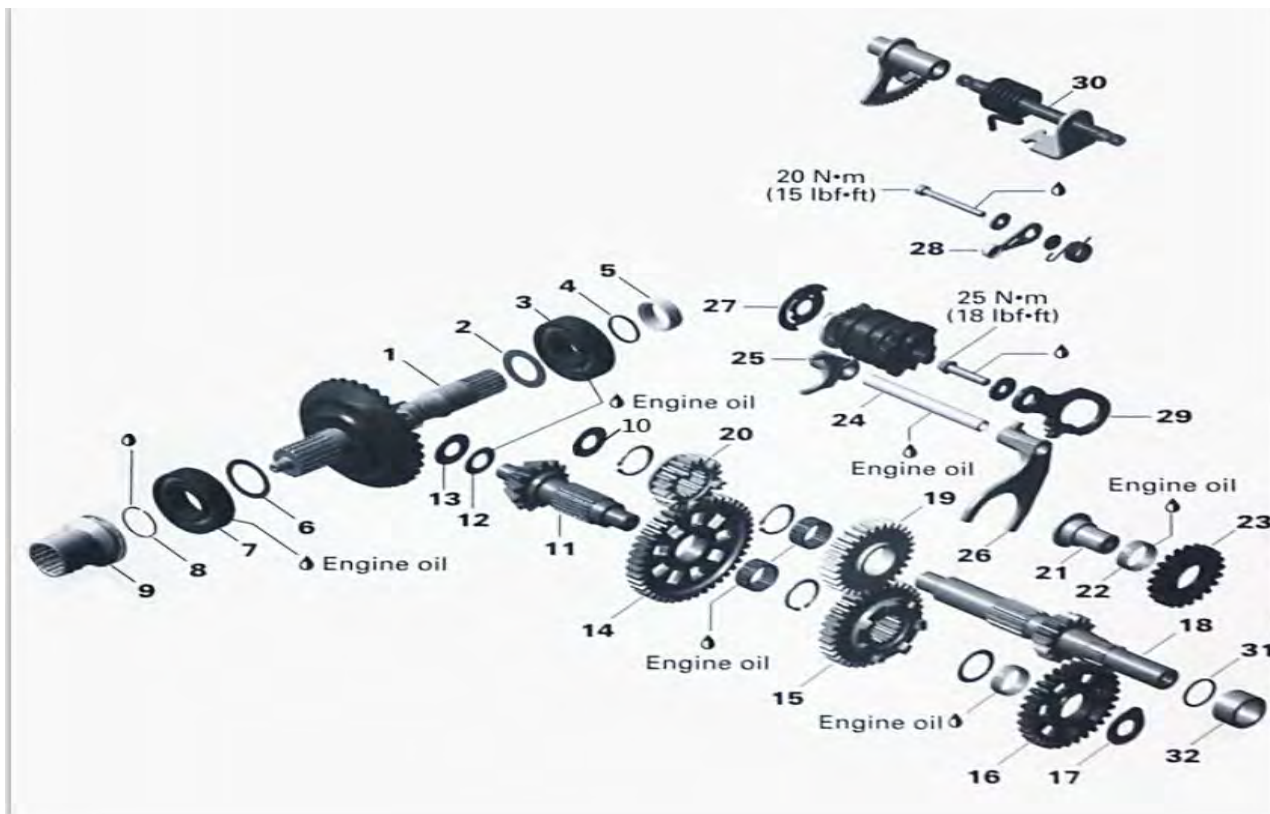

To remove gearbox, the engine removal is necessary. First remove drive and driven pulley and CVT air guide. After unscrew the three (3) nuts attach the gearbox to the engine. Then pull gearbox to separate it from engine. Always drain the gearbox oil before working on.

1. Right housing
2. Center housing
3. Left housing
4. Output shaft
5. Bearing cover
6. Countershaft
7. Shift shaft
8. Cover

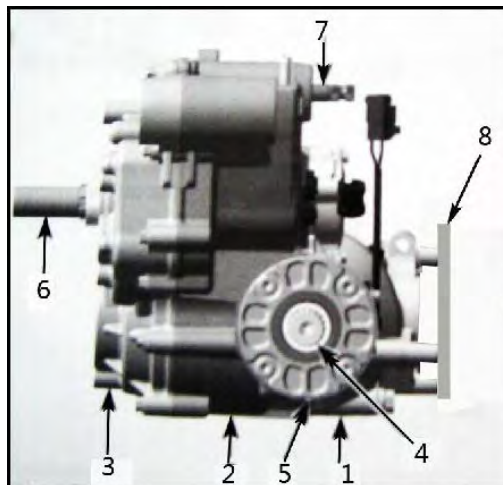

GEARBOX OIL DRAIN

Prior to change the oil, ensure gearbox is on a level surface.

Place a drain pan under the gearbox drain plug area.

Clean drain plug area and remove magnetic drain plug with its sealing ring to drain gearbox oil.

Remove oil filler screw including its o-ring.

CAUTION: Pay attention not to loose O-ring on drain plug screw.

Wait a while to allow oil flow out of gearbox.

1. Magnetic drain plug
2. Sealing ring
3. Oil filler screw

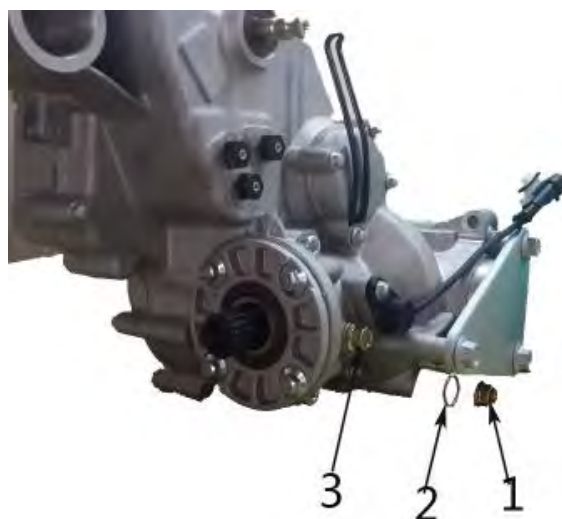

Dispose gearbox oil as per your local environmental regulations.

Inspection

Oil condition gives information about the teeth condition inside the gearbox.

Clean the magnetic drain plug from metal shavings and dirt. Presence of debris gives an indication of failure inside the gearbox. Check gearbox to correct problem.

Change gasket ring on the magnetic drain plug if damaged.

Replace o-ring if brittle, hard or otherwise damaged.

POSTION INDICATOR SWITCHES

NOTE: The gearbox removal is not necessary to reach the gearbox position indicator switches.

Removal

To reach the gearbox position indicator switches, remove the rear engine cover.

Remove screw retaining indicator switch wire.

1. Gearbox position indicator switches
2. BROWN/ GREY wire
3. WHITE/ GREY wire
4. ORANGE/ GREY wire

Unscrew switch.

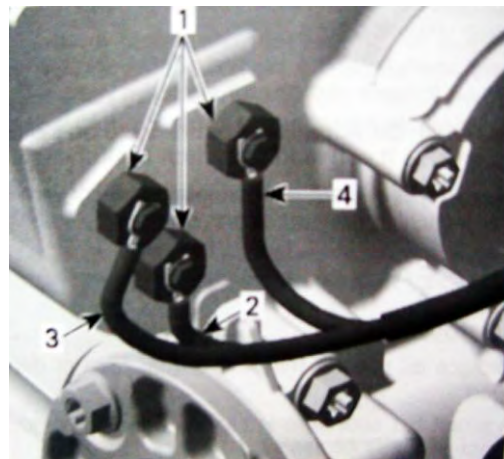
**Test**

Check if gearbox position indicator switches work properly as per following procedure:

NOTE: Remove insulating paint to obtain correct readings.

Put gearbox in park, reverse, neutral, high and low position.

Use a multi meter to measure the resistance from the indicator switch to engine ground. Compare results with the logic table below.

An “x” indicates switch is making ground contact, thus there should be continuity (R is close to 0 ohms)

A blank space indicates switch is not making contact, there should be no continuity (R = infinite). If the indicator switch is good, check the vehicle harness and /or indicator lights.

Shifter position	Corresponding switch wires		
	Brown/grey	White/grey	Orange/grey
L	x		x
H			x
N		x	x
R		x	
P	x	x	

Installation

For installation, reverse the removal procedure.

Pay attention to the following details.

Take care do not damage shifting indicator switched threads during installation.

If all switches are removed, make sure to put the wires back in the right location.

1. Gearbox position indicator switches
2. BROWN/ GREY wire
3. WHITE/ GREY wire
4. ORANGE/ GREY wire

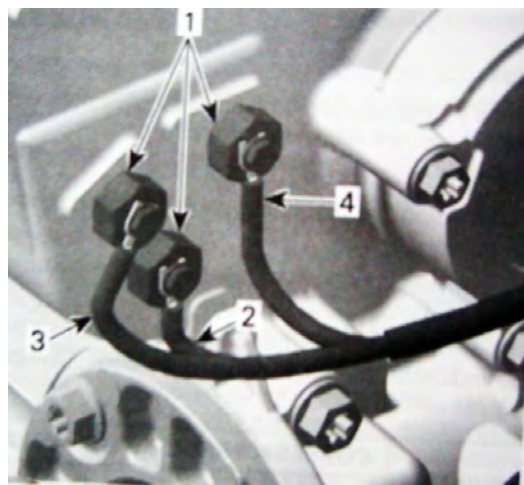

Spray a layer of electrical insulating paint or varnish over switches to prevent shorts and corrosion.

OIL SEALS

Removal

Replace oil seals if they are brittle, hard or damaged.

A small flat screwdriver can be used to remove most of these oil seals.

CAUTION: Avoid scoring housings, bearing cover, shift shaft, distance sleeve of countershaft or output shaft during oil seal removal.

Countershaft oil seal

The countershaft oil seal can be removed without removing gearbox from vehicle. Remove drive and driven pulley and CVT air guide.

NOTE: When oil seal is removed also inspect O-ring

1. Countershaft oil seal
2. Distance sleeve

Shift shaft oil seal

The shift shaft oil seal can be removed without removing the gearbox from the vehicle.

Remove side panel and the shifting plate from shift shaft to reach the oil seal.

Output shaft oil seal

Removal of output shaft oil seal requires that the rear propeller shaft is separated from the output shaft. The removal of the gearbox or bearing cover is not necessary.

NOTE: When oil seal is removed also inspect O-ring

1. Shift oil seal
2. Output shaft oil seal

Inspection

Check bearings behind each oil seal for contamination and / or metal shavings.

Check oil seal running surfaces for scratches. Replace if necessary.

Check if the countershaft O-ring and the output shaft O-ring are brittle, hard or damaged. Replace if necessary.

Installation

The installation is the reverse of removal procedure.

Pay attention to the following details.

Output shaft and countershaft oil seal

Install output shaft oil seal and countershaft oil seal with the oil seal installer.

1. output shaft oil seal
2. oil seal installer

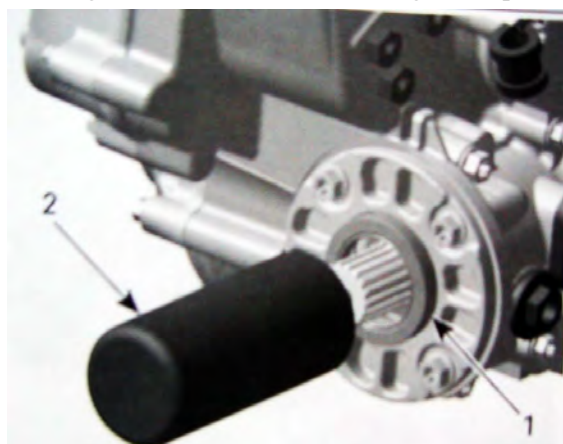
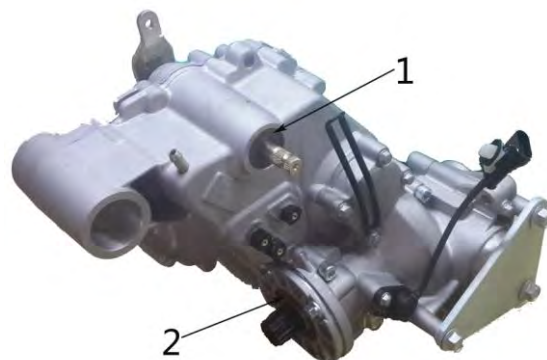

1. countershaft oil seal
2. oil seal installer

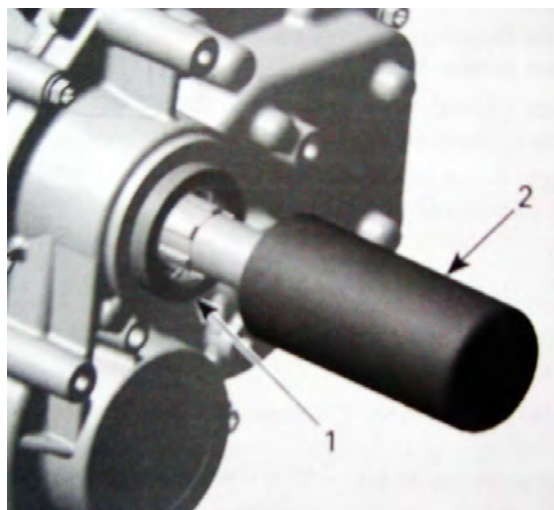

Shift shaft oil seal

Using a suitable tube with the proper diameter to install the shift shaft oil seal.

If gear housing is apart, the oil seal installer and installer handle can be used for shift shaft oil installation.

CUTION: Oil seal must be installed with sealing lip toward gearbox.



OUTPUT SHAFT

Remove gearbox.

Before removing the right housing and output shaft measure the back lash on output shaft. This measure will indicate if output shaft adjustment is necessary.

Output Shaft Back lash Procedure

Engage PARK position on the gear shaft to block gearbox.

Remove:

- bearing cover with oil seal

1. bearing sleeve
2. oil seal

- distance sleeve
- o-ring

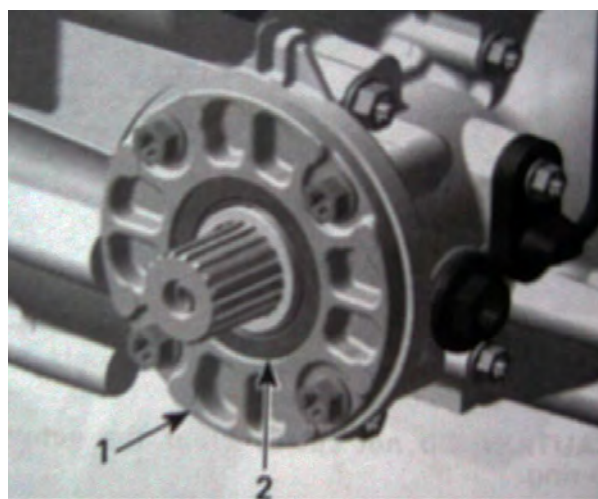

NOTE: It is recommended to apply this specific sealant as described here to get a uniform application without lumps. If you do not use the roller method, you may use your finger to uniformly distribute the sealant (using a finger will not affect the adhesion).

Install all the screws on right housing then the O-ring and the distance sleeve on end of output shaft. Chamfered bore of distance sleeve has to face the engine.

1. distance sleeve
2. O-ring

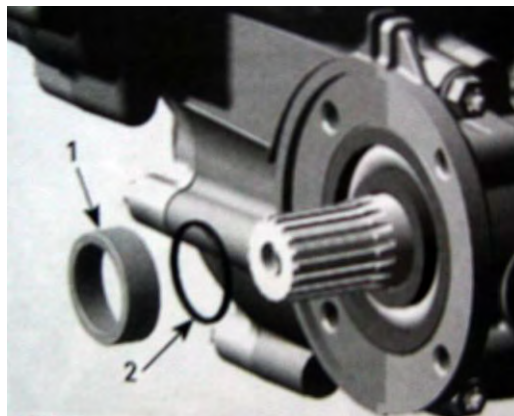

Install the backlash measurement tool at the end of output shaft.

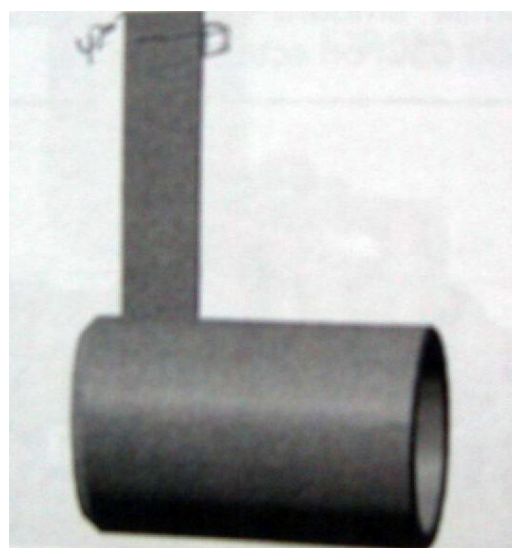

From center of tool bolt, measure 47 mm and place a mark on the tab.

1. back lash measurement tool
 2. mark on tab
- A 47 mm

Position the head of the dial indicator, against the tab at a 90° angle and on the line. Then, gently rotate the output shaft.

This reading gives the back lash measurement.

Refer to the following table for backlash specifications.

Output shaft backlash	
New	0.10 to 0.20 mm
Service limit	0.25 mm

If back lash is not within the specification, remove the output shaft and select the next larger or smaller shim to meet the specifications.

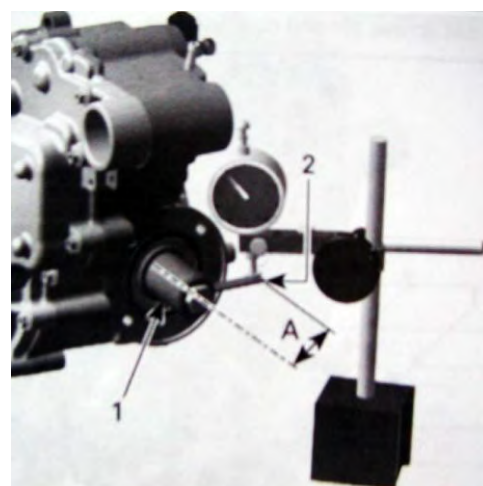

NOTE: Use next lager shim to increase back lash and next small shim to reduce backlash.

Removal

Remove the bearing cover with oil seal.

Unscrew all bolts retaining the right housing to the center housing.

To remove right housing, use 2 big screwdrivers.

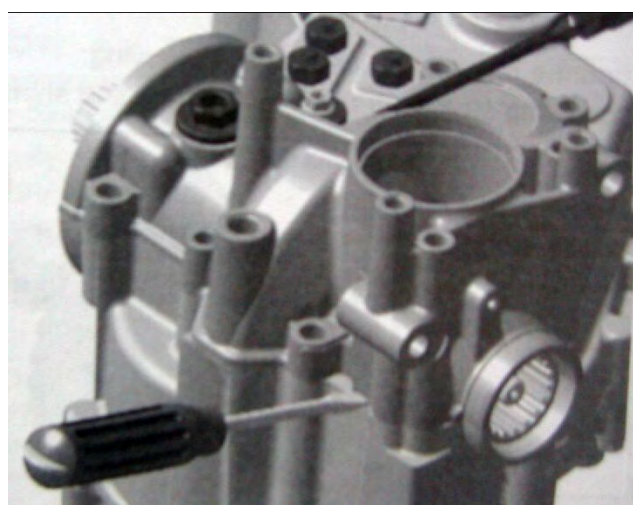
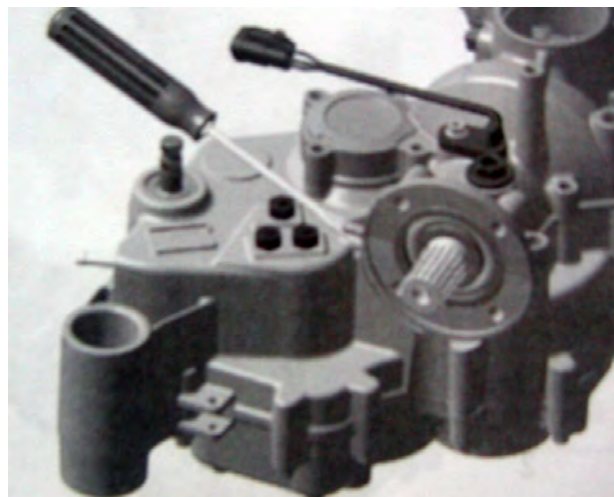

Remove output shaft.

CAUTION: Use a soft hammer to remove output shaft from center housing.

1. output shaft
2. coupling sleeve
3. soft hammer

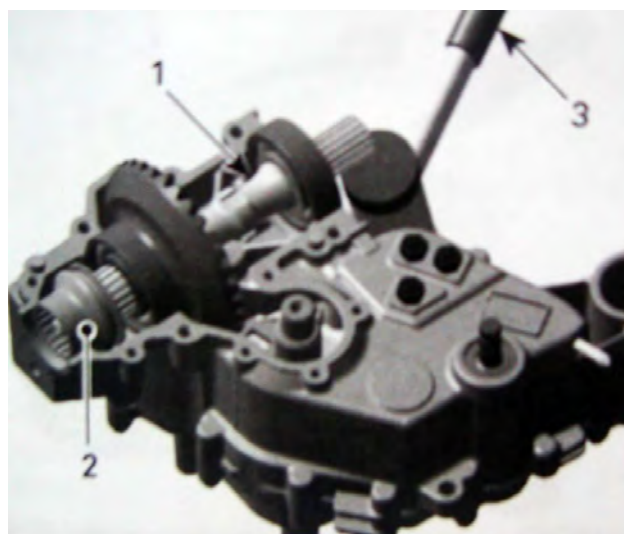

Continue removal procedure by removing:

- coupling sleeve, O-ring, ball bearing and shim.

1. coupling sleeve
2. O-ring
3. ball bearing
4. shim

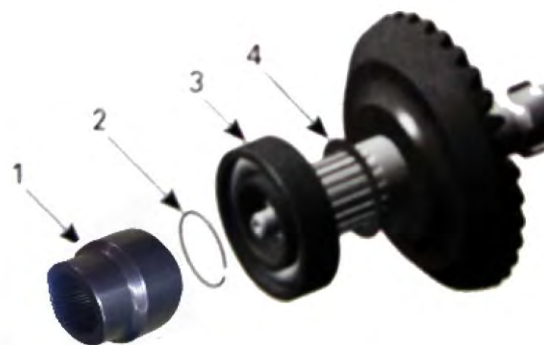

■ ball bearing and thrust washer

1. ball bearing
2. thrust washer



Inspection

Check output shaft and its gear for cracks, bend, pitting or other visible damages.

Check output shaft splines for wear or other damages.

CAUTION: Always replace output shaft and bevel gear shaft at the same time. Adjust these components upon replacement.

Check if the output shaft bearings and turn freely and smoothly. Replace if necessary.

Replace oil seal if brittle, hard or damaged.

Replace O-rings and if brittle, hard or damaged.

Check splines of coupling sleeve for wear or other damages.

1. inspect splines



Installation

Install shim, bearing, O-ring and coupling sleeve onto the output shaft.

Install thrust washer and ball bearing.

O-ring and distance sleeve are not installed at this time.

Place the output shaft into the center housing.

Use soft hammer to put bearing exactly in place against center housing.

Clean the bearing cover location then attach bearing cover with oil seal to the housing.

Temporarily install the right housing with the four (4) M8 screws beside bearing seats.

NOTE: prior to tightening the screws, tap on the gear end of output shaft with a soft hammer to take up all gear free play.

Verify output shaft backlash. Refer to OUTPUT SHAFT BACK LASH PROCEDURE in this section. Adjust as required.

If back lash is with in specifications, remove dial indicator, backlash measuring tool, bearing cover and right housing.

Clean all metal components in a solvent.

Housing mating surfaces are best cleaned using a combination of chisel (gasket remover) and a brass brush. Brush a first pass in one direction then make the final brushing perpendicularly (90°) to the first pass cross (hatch).

CAUTION: Do not wipe with rags. Use a new clean hand towel only.

Important: When beginning the application of sealant, the assembly and the first torquing should be done within 10 minutes. It is suggested to have all you need on hand to save time.

Use LOTITE 5910 on mating surfaces.

Use a plexiglass plate and apply some sealant on it. Use a soft rubber roller (50-75 mm), available in arts products suppliers for printing, and roll the sealant to get a thin uniform coat on the plate (spread as necessary). When ready, apply the sealant on housing mating surfaces.

Do not apply in excess as it will spread out inside housing.

NOTE: It is recommended to apply this specification without lumps. If you do not use the roller method, you may use your finger to uniformly distribute the sealant (using a finger will not affect the adhesion).

Install all other screws on right housing then the O-ring no. 4 and the distance sleeve on end of output shaft. Chamfered bore of distance sleeve has to face the engine.

1. O-ring
2. distance sleeve

NOTE: To install the right housing align the coupling fork no. 10 with the groove in the coupling sleeve no. 9.

First, torque the four (4) M8 screws in a crisscross sequence by hand then retighten to 25 N.m.

Tighten all M 6 screws to 10 N.m.

Before installing bearing cover, apply Loctite 5910 on the housing and Super Lube grease on seal.

Once this is done, complete final assembly.

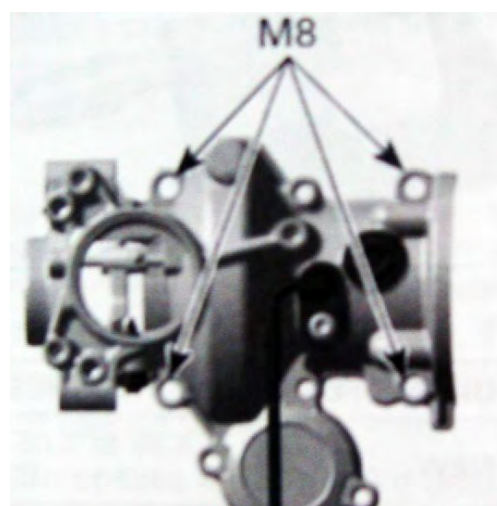
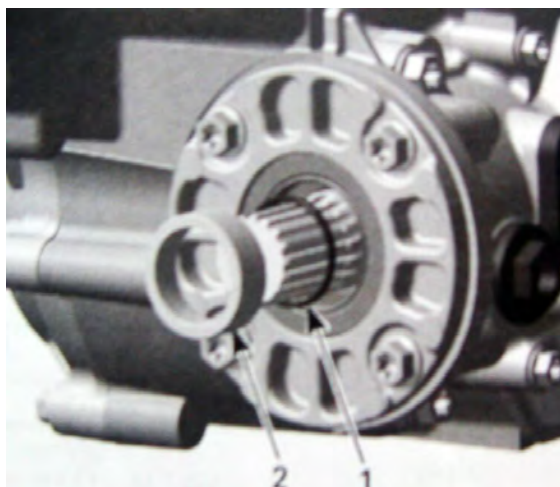

GEARS

Removal

Unscrew the three (3) nuts attach the gearbox to the engine.

Pull gearbox to separate it from engine.

Disassembly

NOTE: During gearbox disassembly, inspect the condition of each part closely.

Remove the output shaft..

Push bevel gear with a pin lightly down and measure the axial clearance of bevel gear with a feeler gauge.

NOTE: Bevel gear axial clearance must be measured before center and left housings separation.

1. bevel gear

Unscrew the left housing screws.

Place the left housing on a wood stand, center housing pointing upwards.

Using 2 big flat screwdrivers, lift the center housing.

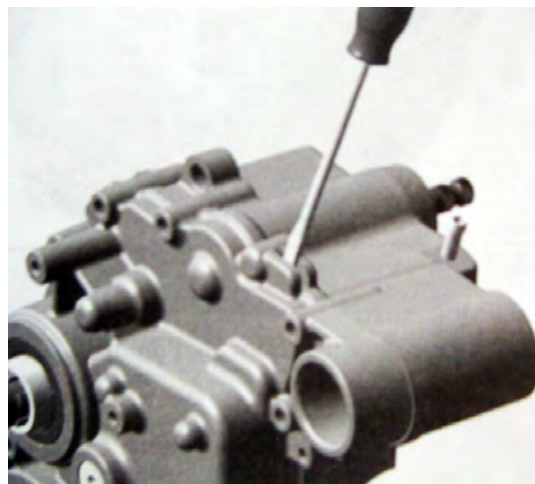
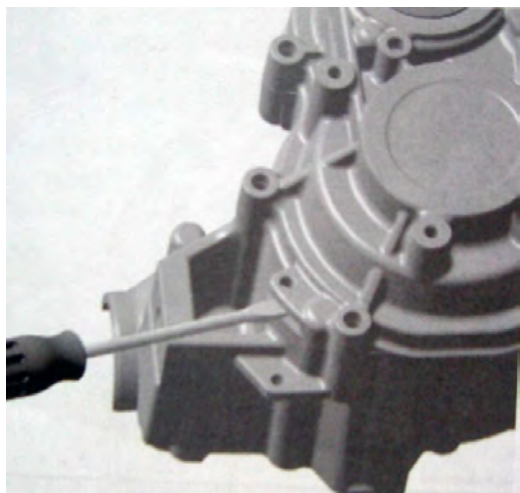
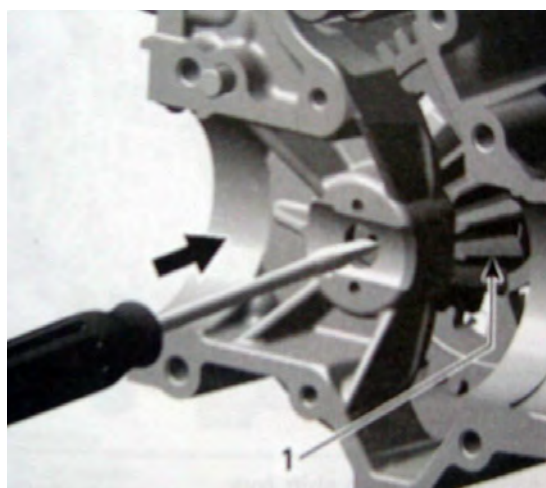

Remove center housing completely.

Remove:

- shift shaft assembly

1. shift shaft assembly

- shift fork shaft
- disengage shift fork from shift drum

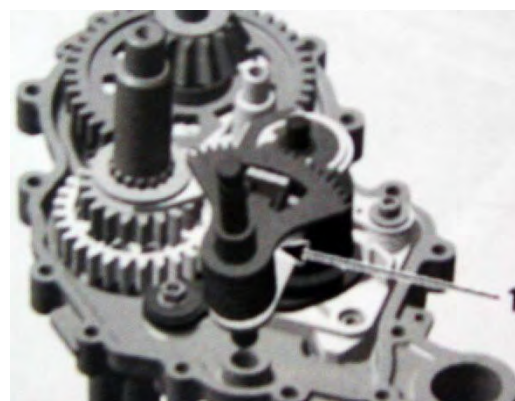

1. shift fork shaft
2. shift fork
3. shift drum

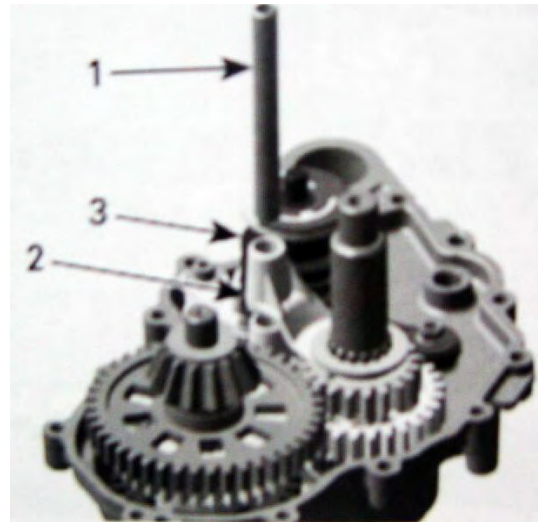

- bevel gear shaft with low range gear assembly and thrust washer

1. bevel gear
2. low range gear
3. thrust washer

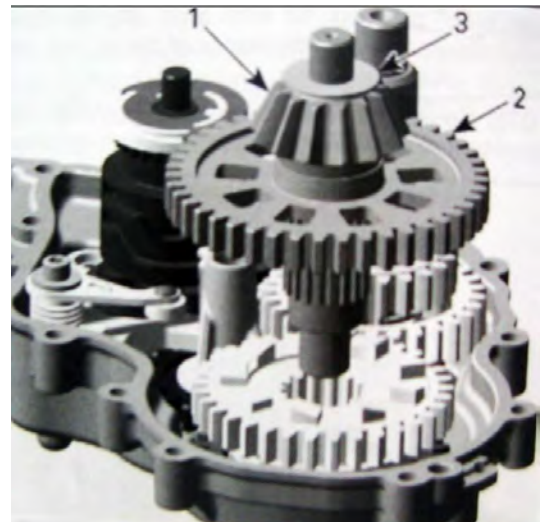

- sliding gear with shift fork

1. sliding gear
2. shift fork



- thrust washer, needle bearing and reverse gear

1. thrust washer
2. needle bearing
3. reverse gear

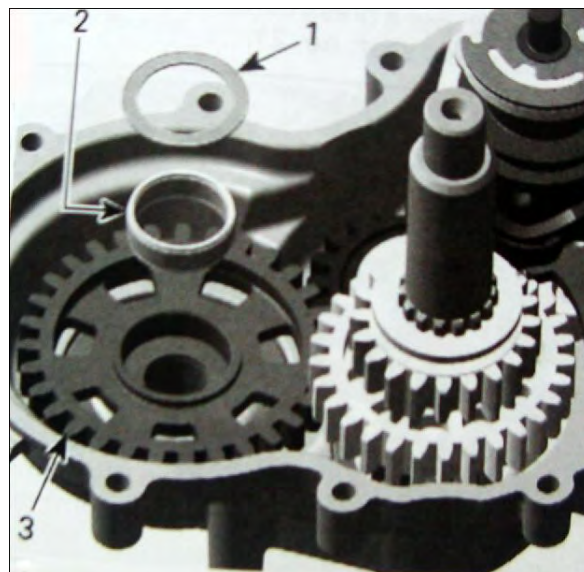

■ thrust washer CVT side

1. thrust washer CVT side



■ countershaft with low range gear and high range gear assembly.

1. countershaft
2. low range gear
3. high range gear

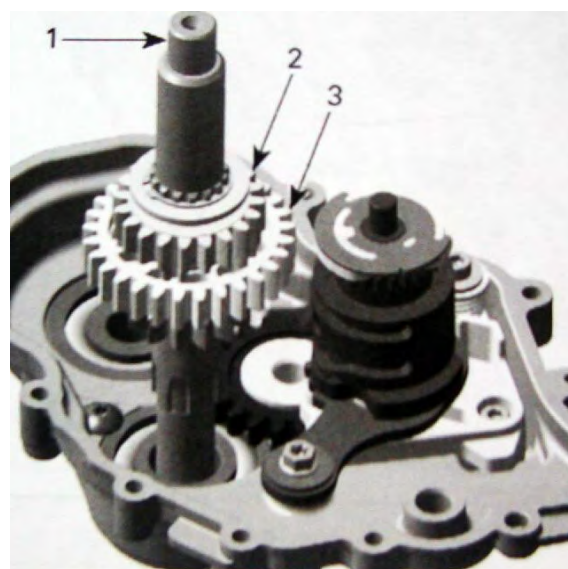

Insert a flat screwdriver in the slot of index lever.
Turn screwdriver clockwise and remove shift drum.

1. index level
2. shift drum



Continue by removing the following:

- parking lock lever

1. parking lock lever

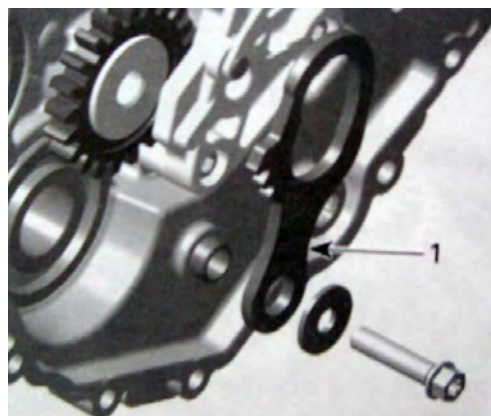

- index lever with washer, step ring and spring

1. index lever
2. washer
3. step ring]
4. index spring

- support flange.



To remove intermediate gear and needle bearing, use a press bench to push out the intermediate gear shaft.

PRESS SHAFT IN THE DIRECTION AS SHOWN BY THE ARROW

1. intermediate gear shaft
2. left housing



Bearing removal in Housing

If necessary heat housing up to 100 °C before removing ball bearings or needle bearings.

CAUTION: Always support gearbox housings properly when ball bearings or needle bearings are removed. Housing damages may occur if this procedure is not performed correctly.

To remove bevel gear needle bearing use a punch.

1. bevel gear needle bearing
2. punch
3. center housing

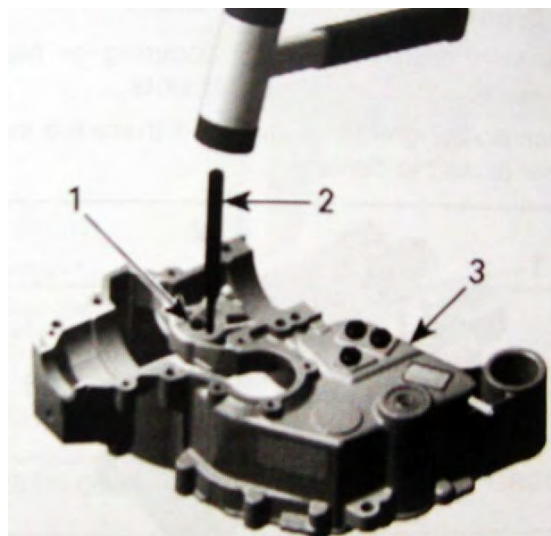

To remove ball bearings of bevel gear and needle bearing of countershaft, use a blind hole bearing puller.



For countershaft ball bearing, remove screw and intermediate gear shaft, then push with a suitable puller from outside in.

1. screw
2. intermediate gear shaft
3. ball bearing countershaft
4. bevel gear ball bearing

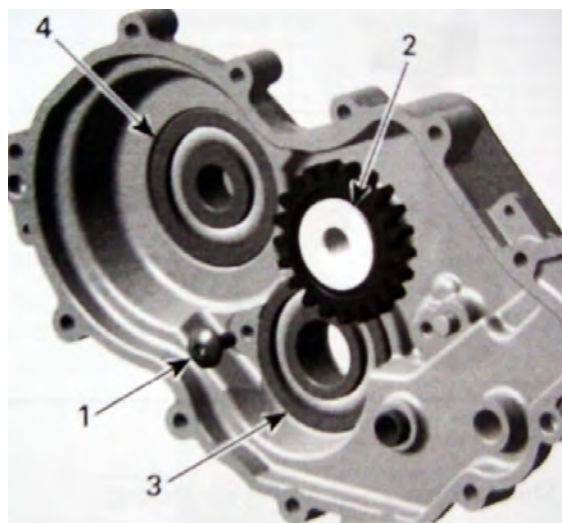
**Inspection**

Always verify for the following when inspecting gearbox components:

- gear teeth damage
- worn or scoured bearing surfaces
- worn or scoured shift fork
- worn or scoured shift fork shaft
- rounded engagement dogs and slots
- bent shift forks
- bent shift fork shaft
- worn shift fork engagement pins
- worn tracks on shift drum
- worn shift fork engagement groove
- worn splines on shafts and gears.

Bearing

Check if bearings as well as needle bearings turn freely and smoothly.

Check all bearings, bearing points, tooth flanks, taper grooves and annular grooves. Annular grooves must have sharp edges.

Shift Forks

Check both shift forks for visible damage, wear or bent shift fork claws.

Measure the shift fork claw thickness.

1. micrometer

A. shift fork claw thickness

Shift fork claw thickness	
New	4.95 to 5.05 mm
Service limit	4.80mm



Measure shift fork pins.

1. micrometer

A. shift fork pin diameter

Shift fork pin diameter	
New	6.942 to 7.00 mm
Service limit	6.850 mm

**Shift Drum**

Check shift drum tracks for scouring or heavy wear, like rounded engagement slots.

Replace isolating washer if there are signs of wear or visible damages.

1. track for the low/reverse gear shift fork

2. track for the high gear shift fork

3. isolating washer on the shift drum

**Levers**

Check parking lever for cracks or other damages.

Index lever with roller must move freely.

Gears

NOTE: Replace gears only together with the corresponding meshing gears. Always replace circlips and use special pliers to install them.

Measure the width of shift fork engagement groove.

1. main gear
2. caliper
- A. width for engagement of shift fork

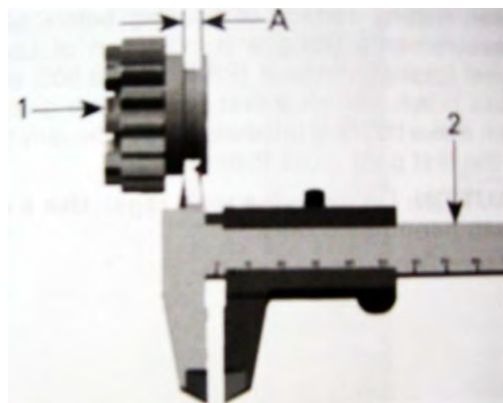

■ gear for high gear shifting.

Width of shift fork engagement groove (high gear shifting)	
New	5.10 to 5.17 mm
Service limit	5.20 mm

■ gear for low/ reverse gear shifting.

Width of shift fork engagement groove (low/reverse gear shifting)	
New	5.10 to 5.17 mm
Service limit	5.20 mm

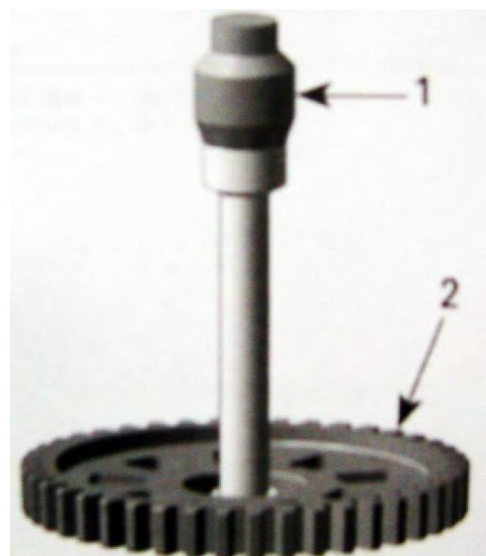

Check free pinion for wear.

1. micrometer
2. free pinion

Diameter free pinion	
New	29.007 to 29.028 mm
Service limit	29.030 mm

Shafts

Check shaft for worn splines and gears.

Check intermediate shaft for wear.

1. intermediate gear bearing

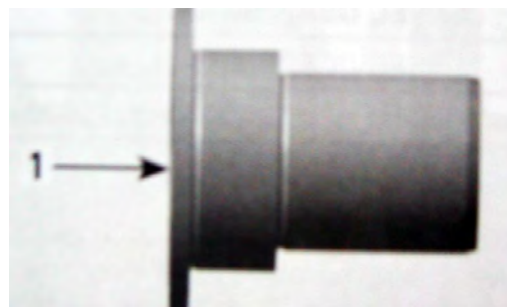

Intermediate gear shaft	
New	24.980 to 24.993 mm
Service limit	24.977 mm

Check countershaft for wear.

1. MAG side
2. free pinion bearing
3. CVT side



Countershaft	
Service limit	
MAG side	17.974 mm
Free pinion bearing	24.970 mm
CVT side	24.970

Check bevel gear shaft.

1. free pinion bearings

Bevel gear shaft	
Service limit	
Free pinion bearing	24.972 mm



Shims

Always replace shim by a new one with the same thickness, when reassembling the gearbox with existing output shaft and bevel gear shaft.

1. thrust washer for adjusting the bevel gear on center housing side
2. area where wear signs appear
3. thickness of the washer

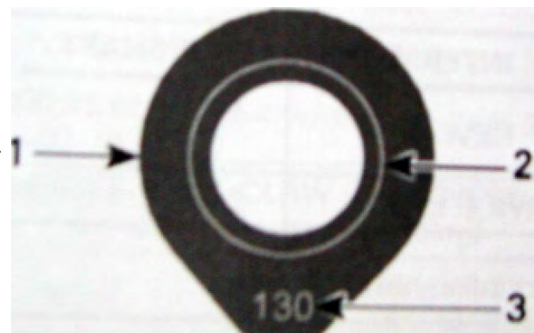

Bevel Gear Adjustment

NOTE: Only necessary if backlash and axial clearance of the bevel gear is out of specification or if parts are changed (output shaft, bevel gear shaft or housing).

There are 2 adjustments to perform on the bevel gear.

- bevel gear backlash on center housing
- bevel gear axial clearance on left housing.

The bevel gear backlash is adjusted by finding the proper thrust washer thickness E as per following illustration.

The bevel gear axial clearance is adjusted by finding the proper thrust washer thickness J as per following illustration.

Clean mating surface of housing before taking measurements.

CAUTION: Do not wipe with rags. Use a new clean hand towel only.

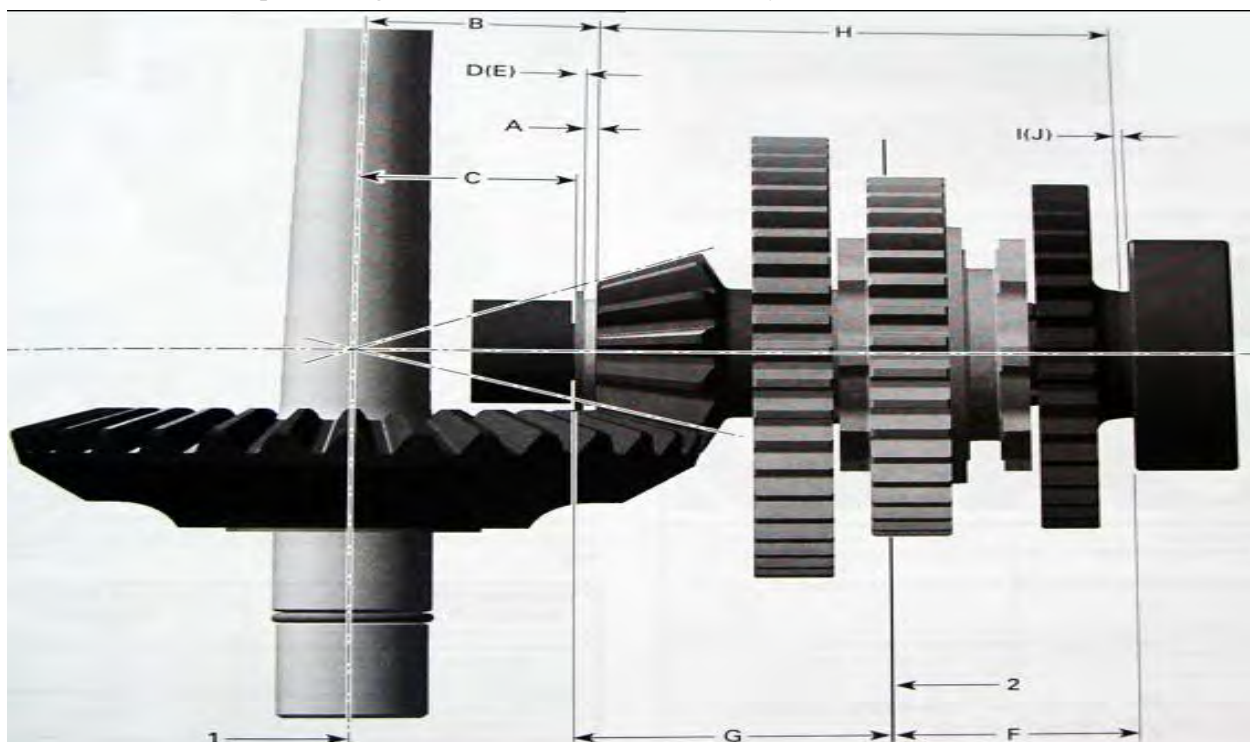

Bevel Gear Back lash Procedure

Use the following course of calculation to determine the theoretical thrust washer thickness D:

$$D = B - C - A$$

B = the distance between the thrust surface of the bevel gear and the theoretical center of its taper. This is defined by manufacturer and is written on the bevel gear shaft.

This bevel gear reference number could be between -10 and + 10.



1. bevel gear
2. bevel gear reference number

Use following formula to find out value **B**.

$$B = \frac{(\text{bevel gear reference number})}{100} + 37.8$$

For example: Bevel gear reference number = -3.

$$B = \frac{(-3/100)}{100} + 37.8 = 37.77$$

C = Distance between the shim thrust surface in the center housing and the mating surface to left housing.

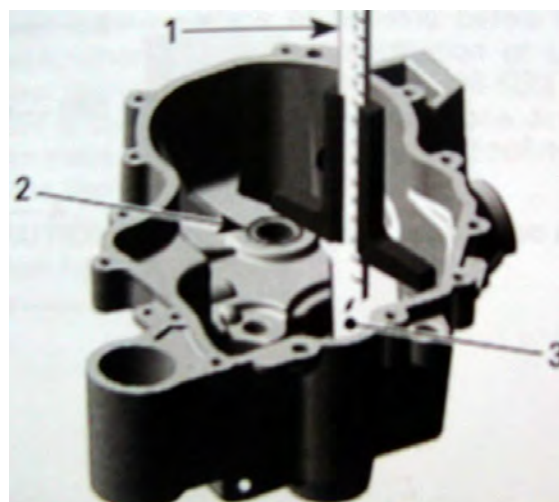

1. deep gauge – measurement C
2. thrust washer surface in center housing
3. mating surface to left housing

A = 2 mm nominal thickness of axial needle bearing .

When the measurements are taken, calculate the theoretical thrust washer thickness **D** using the formula (**D = B – C – A**)

Take the obtained theoretical thrust washer thickness **D** and choose the corresponding thrust washer number **E** according to the following table.

NOTE: For example, if the theoretical thrust washer thickness **D** is 1.53 mm, choose the corresponding thrust washer number 150 **E**. the thrust washer number 150 represents a nominal value equal to 1.50 mm.

Theoretical Thrust Washer Thickness D	Thrust Washer Number E
1.20 mm to 1.29 mm	120
1.30 mm to 1.39 mm	130
1.40 mm to 1.49 mm	140
1.50 mm to 1.59 mm	150
1.60 mm to 1.69 mm	160
1.70 mm to 1.79 mm	170
1.80 mm to 1.89 mm	180

Bevel Gear Axial Clearance Procedure

Use the following course of calculation to determine the theoretical thrust washer thickness **I**:

$$I = F + G - H - A - E$$

F = Distance between mating surface of left housing to ball bearing inner race.

1. ball bearing inner race
2. mating surface of left housing
3. depth gauge

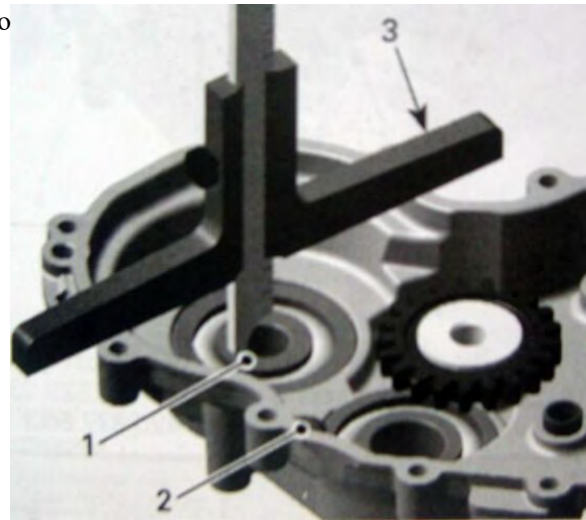

G = Distance between mating surface of center housing and thrust washer surface.

1. mating surface of center gear housing
2. thrust washer surface

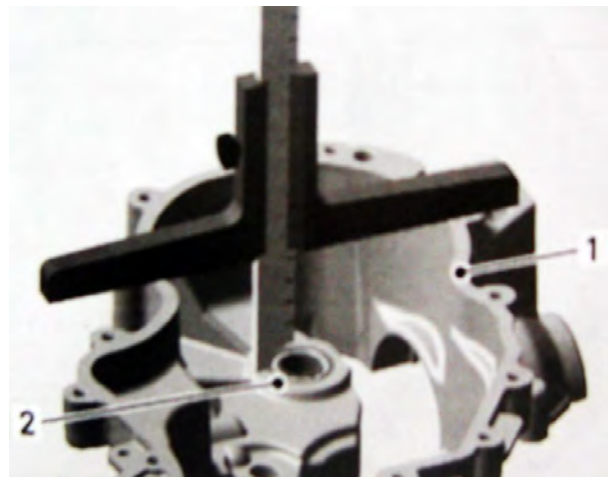

H = Distance between thrust surface of bevel gear shaft.



A = 2mm nominal thickness of axial needle bearing no. 12 .

E = the thrust washer number nominal value as found in the *BEVEL GEAR BACKLASH PROCEDURE*. For example, thrust washer number 150 represents a value of 1.50 mm.

When the measurements are taken, calculate the theoretical thrust washer thickness I using the formula $(I = F + G - H - A - E)$

Take the obtained theoretical thrust washer thickness I and choose the corresponding thrust washer number J according to the following table.

For example, if the theoretical thrust washer thickness I is 1.53 mm, choose the corresponding shim number 150 J.

Bevel gear axial clearance of 0.02 to 0.11 mm is included in the table.

THEORETICAL THRUST WASHER THICKNESS I	THRUST WASHER NUMBER J
1.22 mm to 1.31 mm	120
1.32 mm to 1.41 mm	130
1.42 mm to 1.51 mm	140
1.52 mm to 1.61 mm	150
1.62 mm to 1.71 mm	160
1.72 mm to 1.81 mm	170
1.82 mm to 1.91 mm	180

Assembly

The assembly of gearbox is essentially the reverse of disassembly procedure. However, pay attention to the following details.

Bearing Installation in Housing

Unless otherwise instructed, never use hammer to install ball bearings or needle bearings. Use press machine only.

If necessary heat housings up to 100°C before installing ball bearings or needle bearings.

Place new bearing in freezer for 10 minutes before installation.

Use a suitable installer for installing ball bearings of countershaft and bevel gear.

NOTE: Place gearbox housings on a wood stand before installing bearings.

Install countershaft needle bearing with the main shaft needle bearing installer and the installer handle in right housing.

1. needle bearing installer
2. installer handle



1. countershaft needle bearing
2. right housing
3. needle bearing installer
4. installer handle

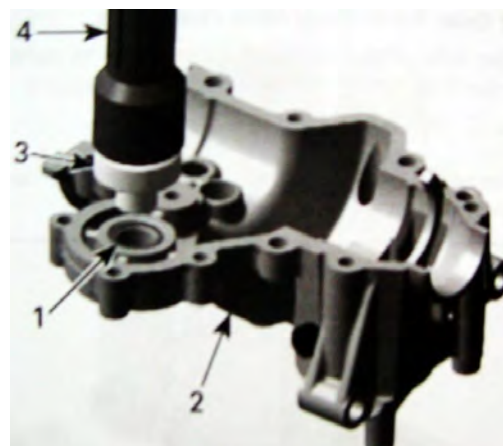

Install bevel gear needle bearing using the bevel gear needle bearing installer and the installer handle.

1. bevel gear needle bearing
2. center housing
3. needle bearing installer
4. installer handle

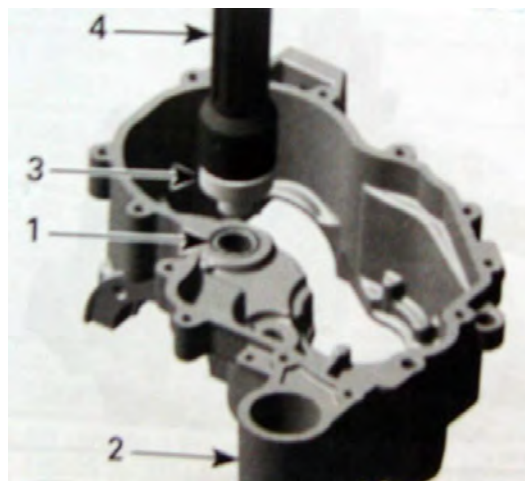

Install new oil seals with the proper installer.

Other Gearbox Components

Fit intermediate gear with needle bearing on intermediate gear shaft.

NOTE: Fit gear with collar face to housing side on the intermediate shaft.

1. intermediate gear
2. collar facing housing
3. needle bearing
4. intermediate gear shaft

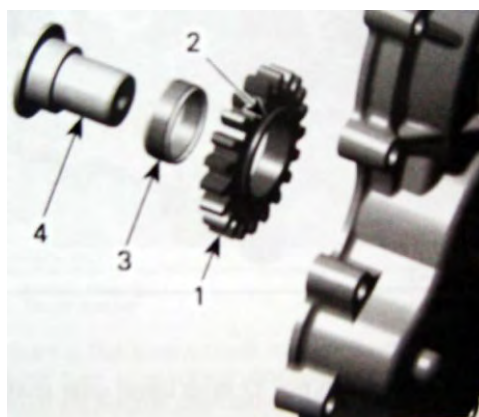

Press intermediate gear shaft in the left housing.

1. intermediate gear shaft



Fit support flange in the left housing and install index lever.

NOTE: Fit step ring into index lever.

1. shim
2. index lever
3. step ring
4. index spring

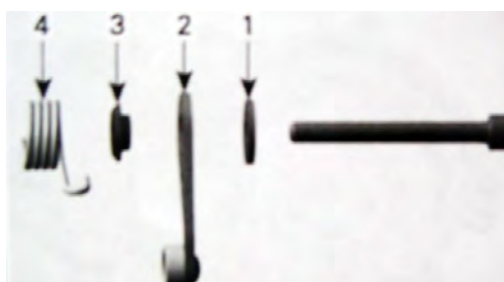

Install parking lock level, teeth showing to countershaft.

1. parking lock lever

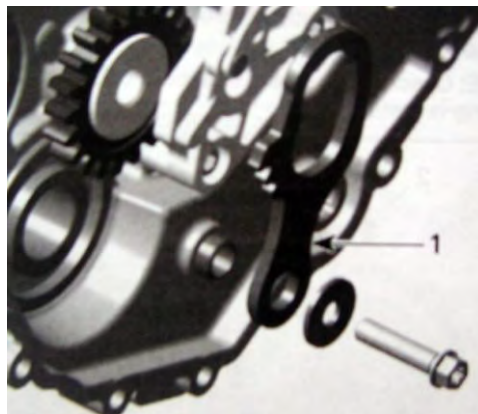

Place thrust washer CVT side on bearing.

1. thrust washer CVT side



Place reverse gear with needle bearing and thrust washer.

NOTE: Check if the screw to secure countershaft bearing is installed.

1. reverse gear
2. needle bearing
3. thrust washer
4. countershaft bearing screw

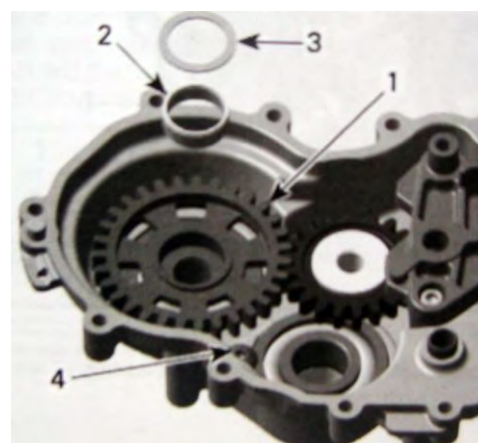

Install countershaft with low gear and high gear assembly.

1. countershaft
2. low gear
3. high gear

Install a new shim onto bevel gear shaft, fork side.

Install bevel gear with sliding gear assembly together with shift fork.

NOTE: If a new bevel gear and output shaft are used, it is necessary to verify the shim adjustment prior to

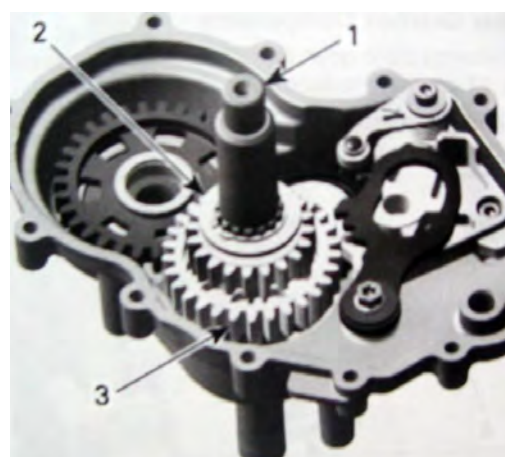

finalize assembly. Refer to *ADJUSTMENT* above in this section. If the existing bevel gear is used, it is mandatory to use a new shim with the same thickness, a new needle bearing and thrust washer .

1. bevel gear
2. sliding gear
3. shift fork



Install a new needle bearing and thrust washer.

1. needle bearing
2. thrust washer



Insert a flat screwdriver in the slot of the index lever, turn screwdriver clockwise and install shift drum on neutral position as per following illustration.

1. index lever
2. shift drum
3. neutral position



1. parking stop location
2. reverse stop location
3. neutral stop location
4. high gear stop location
5. low gear stop location

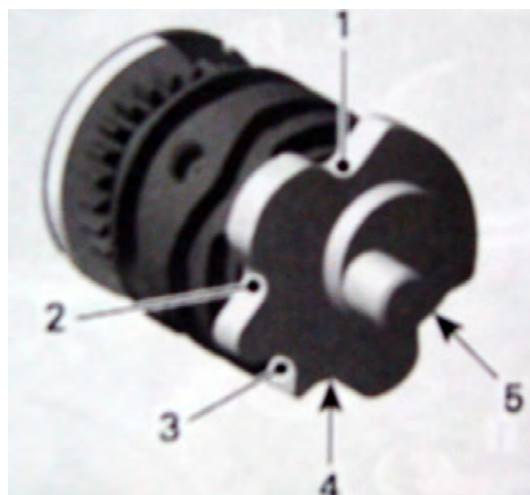

Install shift shaft assembly.

NOTE: Marks on shift drum/isolating washer and shift shaft must align.

1. shift shaft assembly
2. isolating washer
3. marks

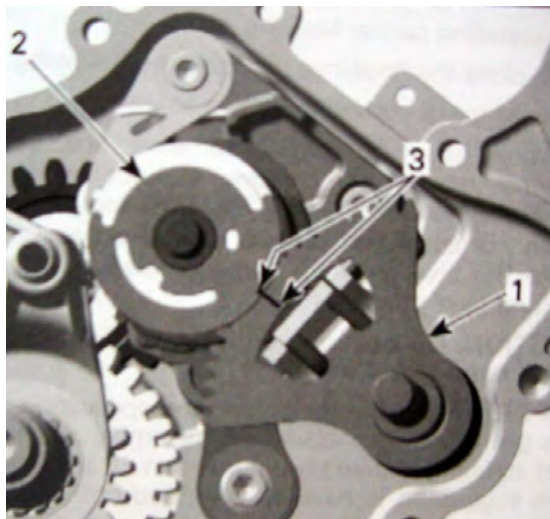

Install shift fork then engage both shift fork pins in their corresponding groove on the shift drum.

NOTE: move sliding gears to facilitate engagement of pins inside grooves.

1. shift fork pin
2. sliding gear

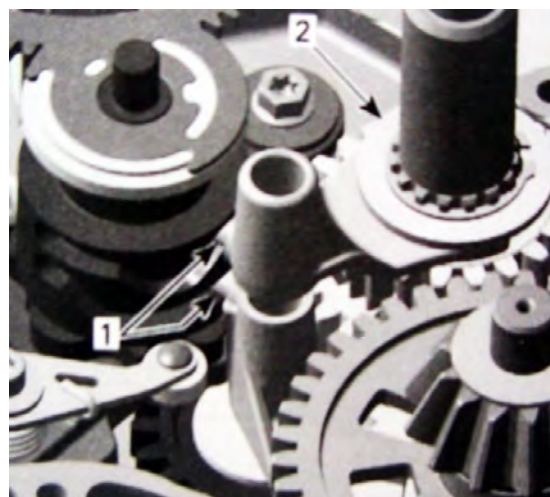

Install shift fork.

NOTE: Run all gears as a final function check before installing center housing.

Now, close the housings by doing the following:

Clean all metal components in a solvent.

Gearbox housing mating surfaces are best cleaned.

CAUTION: Do not wipe with rags. Use a new clean hand towel only.

IMPORTANT: When beginning the application of the gear housing sealant, the assembly and the first torquing should be done within 10 minutes. It is suggested to have all you need on hand to save time.

Use Loctite 5910 on mating surfaces.

Use a plexiglass plate and apply some sealant on it. Use a soft rubber (50-75 mm), available in arts products suppliers for printing, and roll the sealant to get a thin uniform coat on the plate (spread as necessary). When ready, apply the sealant on gear housing mating surfaces.

Do not apply in excess as it will spread out inside gear housing.

NOTE: It is recommended to apply this specification without lumps. If you do not use the roller method, you may use your finger to uniformly distribute the sealant (using a finger will not affect the adhesion).

Hand-torqued gear housing screws in a crisscross sequence. Repeat procedure, retightening all screws to **10 N.m**.

Install O-ring including distance sleeve on countershaft CVT side.

CAUTION: Place O-ring including distance sleeve right away. Chamfered bore of distance sleeve has to face the gearbox.

Installation

The installation is the reverse of the removal procedure.

Filling Procedure

Make sure that magnetic drain plug is reinstalled and tight.

With the gearbox on a level surface, fill the gearbox through the oil filler hole with GL-4-90 or with an equivalent product until the oil reaches the lower threads of the oil filler hole (about 420 ml).

ENGINE INSTALLATION

The engine installation is the reverse of the removal procedure. However, pay attention to the following.

1. Prior to install engine, inspect condition of engine mounts. If necessary, replace the engine mounts, you can insert a punch in hole of engine mount bushing and push the other bushing out of the housing.
2. Make sure coolant and oil drain plugs are reinstalled and tight.

Refill engine oil and check the oil level with the dipsti

4. COOLING SYSTEM

FAULT OVERHAULING	4-1	COOLING SYSTEM TEST	4-2
THERMOSTAT	4-3	RADIATOR AND CAP	4-3
COOLANT TANK	4-4	RADIATOR FAN	4-4
WATER PUMP HOUSING	4-6	WATER PUMP IMPELLER	4-6
WATER PUMP SHAFT AND SEALS	4-7		

Fault overhauling

1. If cover of radiator is open and temperature of cooling liquid is over 100°C, pressure of cooling liquid will be reduced rapidly and boiled. Vapor injection may cause danger and injuries. After drop of temperature of cooling liquid, use one cloth to cover the cover of radiator and then slowly open the cover. Cooling liquid can only be tested after complete cooling.
2. Cooling liquid is toxic. Do not drink it or splash it to skin, eyes or clothes. In case of splashing cooling liquid to your eyes, use clean water to wash your eyes completely and see the doctor. In case of splashing cooling liquid to your clothes, use soapy water to wash it rapidly. In case of drinking cooling liquid, vomit will be caused immediately. Please see the internist physician immediately. Store cooling liquid well and keep it out of reach of children.
2. Check whether soil of fins is blocked or damaged. Correct curved fins. Use water and compressed air to clean soil. If damaged area reaches 20%, please replace radiator.
3. Pump overhauling can be carried out before dismantling engine.
4. Add cooling liquid to water tank. In addition to adding or exhausting cooling liquid, please do not open cover of radiator.
5. Do not splash cooling liquid to plastic parts. Once splashed, please use clean water for washing.
6. After dismantling cooling system, check leakage situation of joint.

Sharp rise of water temperature

- z Faults of radiator cover
- z There is air in cooling system.
- z Faults of water pump
- z Faults of thermostat (thermostat is not open)
- z Blockage of radiator tube or cooling tube
- z Damage or blockage to radiator
- z Incomplete cooling liquid
- z Failure or faults of fan motor

No rise or slow rise of water temperature.

- Z Faults of thermostat (thermostat is not closed)
- Z Faults of line of water temperature display

Leakage of cooling liquid

- z Faults of water seal
- z Aging, damage or improper sealing to O-shaped ring.
- z Aging, damage or improper sealing to gasket
- z Improper installation of pipe or hose
- z Aging, damage or improper sealing to pipe and/or hose

! Warning

Never start engine without coolant. Some engine parts such as the rotary seal on water pump shaft can be damaged.

COOLING SYSTEM TEST

! WARNING

To avoid potential burns, do not remove the radiator cap or loosen the cooling drain plug if the engine is hot.

Open the upper cover of engine hood and remove the radiator cap.

Install the test cap and a small hose pincher on overflow hose.

Using pressure/ vacuum pump, pressurize system to 100 kPa.

Check all hoses, radiator and cylinder(s)/base for coolant leaks or air bubbles.



Inspection

Check general condition of hoses and clamps tightness.

Check the leak indicator hole if there is oil or coolant.

NOTE: Flowing coolant indicates a defective rotary seal. Oil indicates a defective inner oil seal. If either seal is leaking, both seals must be replaced at same time. Refer to *WATERPUMP SHAFT AND SEAL* in this section.

1. leak indicator hole

Another leak indicator hole is visible on the PTO side. It indicate if the PTO gasket is in good condition. If a liquid leaks by this hole, the PTO gasket replacement is necessary.

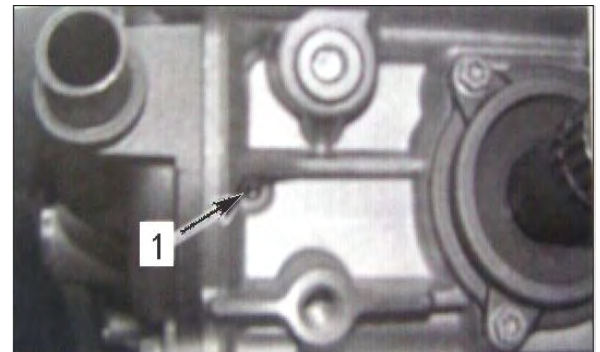

THERMOSTAT

The thermostat is a single action type. The thermostat is located on the top of cylinder head, on intake side.

Remove:

- thermostat housing screws and pull thermostat cover

1. Thermostat cover
2. Screws

- thermostat with gasket out of the hole.

Thermostat Test

To check thermostat, put in water and heat water.

Thermostat should open when water temperature reaches 65°C (149°F).

Check if the gasket is brittle, hard or damaged. If so replace gasket.

Thermostat Installation

For installation, reverse the removal procedure, pay attention to the following details.

Install the thermostat cover then torque screws to 6N.m.

Check coolant level in radiator and coolant tank and top up if necessary.

Do not forget to bleed the cooling system. Refer to *COOLANT REPLACEMENT*.

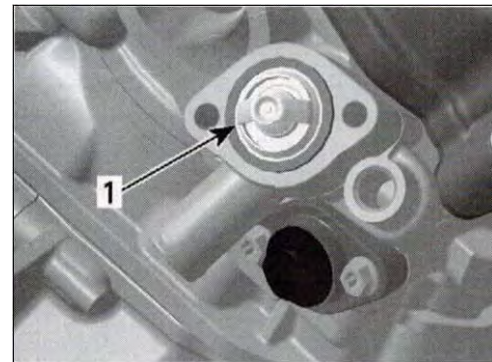
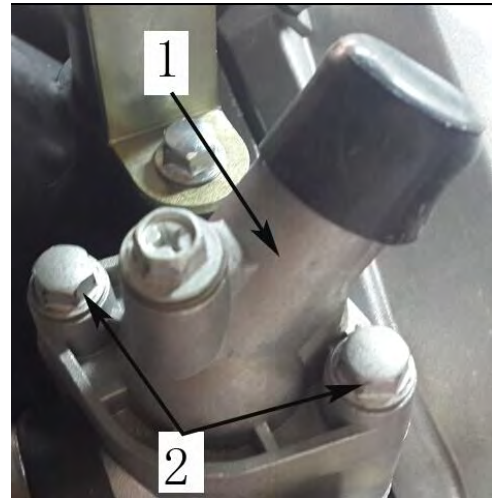

RADIATOR AND CAP

Using a pressure cap tester, check the efficiency of radiator cap. If the efficiency is feeble, install a new 100 kPa cap (do not exceed this pressure).

Radiator Inspection

Check radiating fins for clogging or damage.

Remove insects, mud or other obstructions with compressed air or low pressure water.

Radiator Removal

Drain cooling system.

Remove front fascia and radiator shroud.

Remove:

- Radiator inlet and radiator outlet hoses
- Overflow hose.
- Remove radiator.

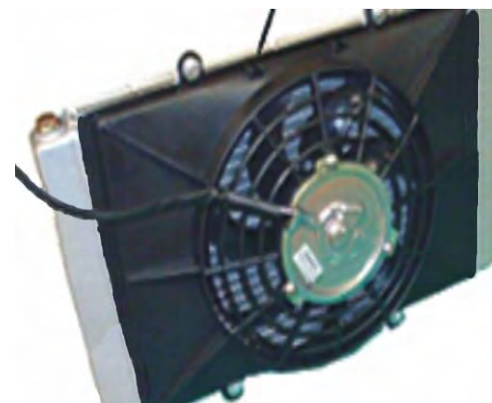

Radiator Installation

For installation, reverse the removal procedure.

Pay attention to the following detail.

Fill up the radiator. Refer to *COOLANT REPLACEMENT*, in this section.

Check for any coolant leakage from radiator and hoses.

COOLANT TANK

The coolant expands as the temperature (up to 100-110°C) and pressure rise in the system. If the limiting system working pressure cap is reached 110kPa, the pressure relief valve in the pressure cap is lifted from its seat and allows coolant to flow through the overflow hose into the overflow coolant tank.

Tank Removal

Remove:

- The upper cover of engine hood.
- Coolant tank support bolt and.
- Overflow hose and clamp.

Tank Installation

The installation is the reverse of the removal procedure.

RADIATOR FAN**Radiator Fan Removal**

Remove radiator shroud.

Remove bolts.

Remove the radiator fan.

Radiator Fan Test

NOTE: The ECM controls the radiator fan via the input of the coolant temperature sensor (CTS). The radiator fan should turn on when coolant temperature reaches 98°C and should turn off when the coolant cools down at 95°C.(203°F).

Connect the vehicle to B.U.D.S. Refer to ENGINE MANAGEMNT for procedure and connector location.

In ACTIVATION folder, press COOLANT FAN button.

If fan turns, check CTS, wiring harness and connectors. If all parts are good, replace the ECM.

If fan does not turn when COOLANT FAN button is pressed, use the following troubleshooting chart to resolve the problem.

Radiator Fan Installation

For the installation, reverse the removal procedure

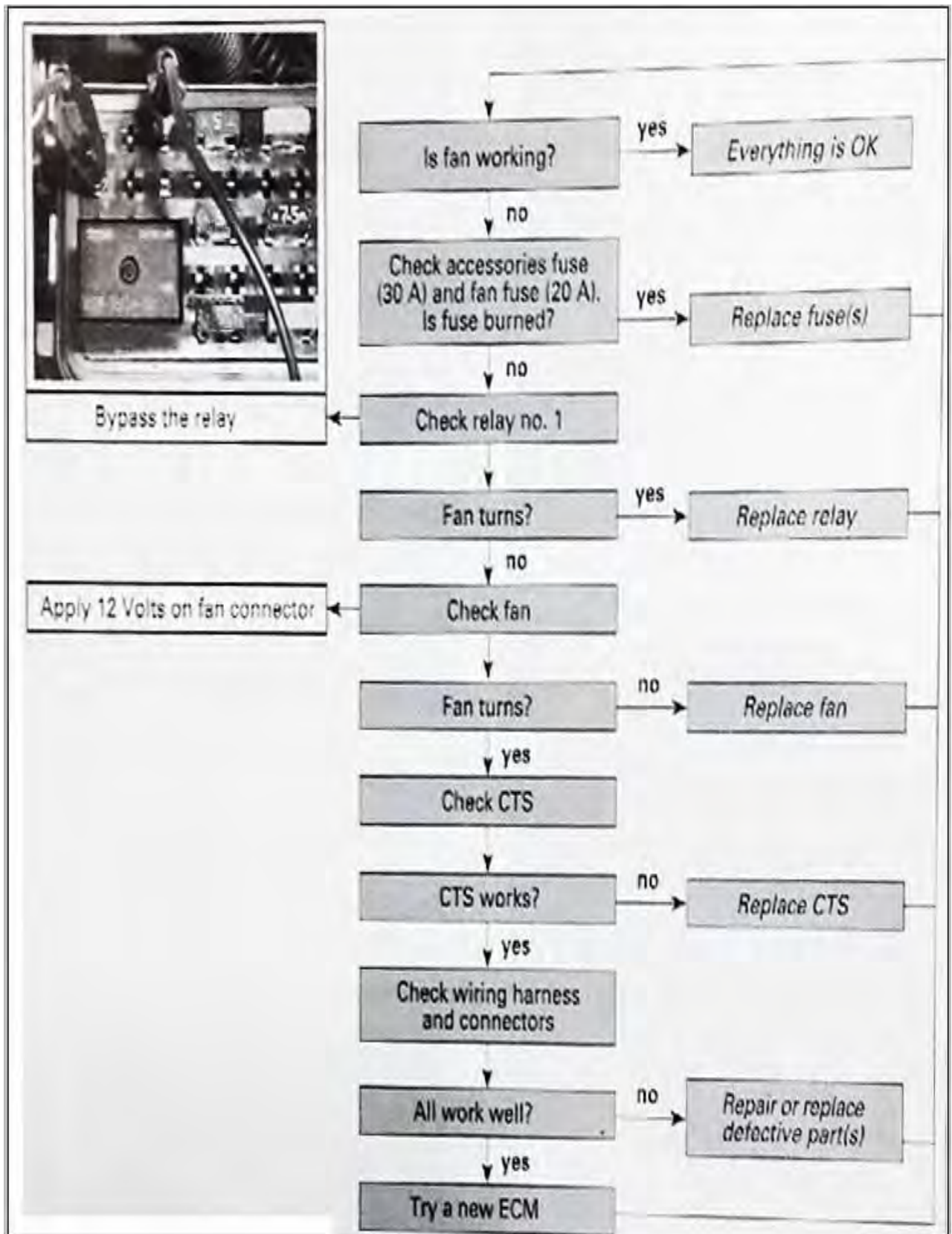

WATER PUMP HOUSING

It is located on the engine MAG side.

Water Pump Housing Removal

Drain cooling system.

Remove radiator outlet hose from water pump housing.

Remove screws retaining water pump housing.

1. Screws
2. Water pump housing
3. Sealing ring

Pull water pump housing to remove it.

Water Pump Housing Inspection

Check if gasket is brittle, hard or damage and replace as necessary.

1. Gasket

Water Pump Housing installation

The installation is the opposite of the removal procedure.

CAUTION: To prevent leaking, take care that the gasket is exactly in groove when you reinstall the water pump housing.

Tighten screws of water pump housing in a criss-cross sequence.

WATER PUMP IMPELLER

Impeller Removal

Remove water pump housing.

Unscrew impeller.

1. Impeller

CAUTION:

Water pump shaft and impeller have right-hand threads. Remove by turning counterclockwise and install by turning clockwise.

Check impeller for cracks or other damage. Replace impeller if damaged.

Impeller Installation

The installation is the opposite of the removal procedure. Be careful not damage impeller wings during installation.

! WARNING

To avoid potential burns, do not remove the radiator cap or loosen the cooling drain plug if the engine is hot .

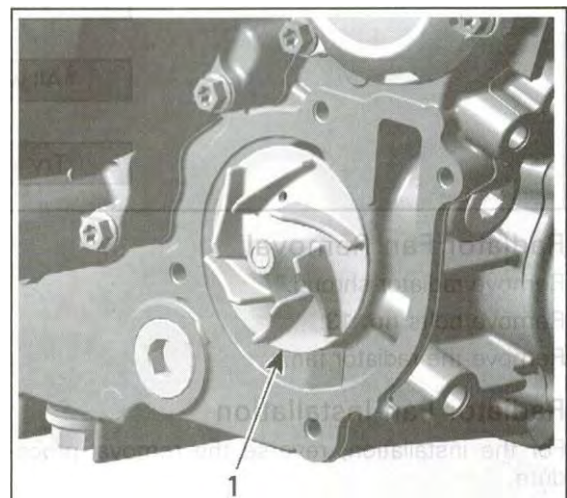
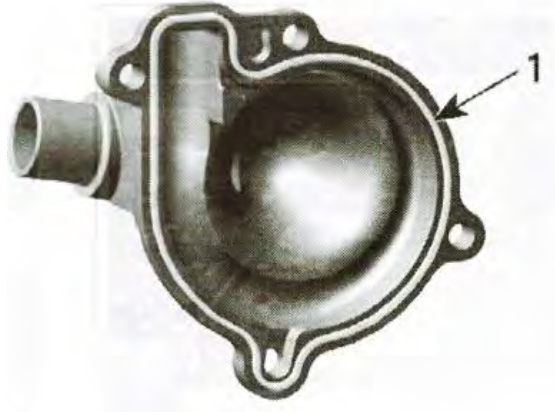
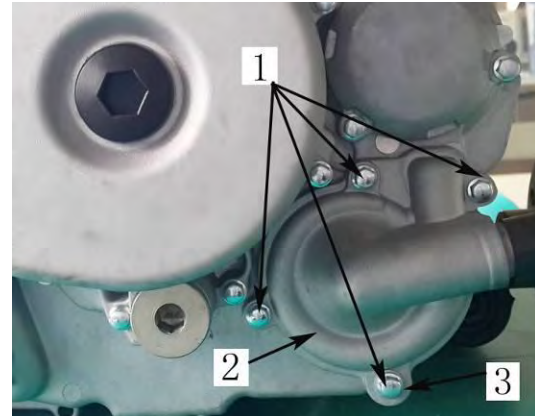

WATER PUMP SHAFT AND SEALS

Shaft/Seal Removal

NOTE: It is not required to split crankcase to replace the water pump shaft and seals, but engine removal is necessary.

Drain engine oil.

Remove engine from vehicle. Refer to ENGINE REMOVAL AND INSTALLATION section.

Detach gearbox from engine.

Remove engine drive shaft and engine PTO cover.

Remove water pump housing and impeller. See procedures in this section.

Pull out water pump gear to disengage the inner drive gear.

1. water pump gear
2. Inner drive gear

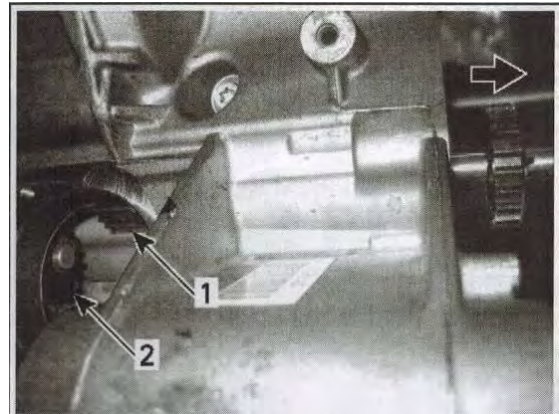

Sharply strike water pump shaft out with a plastic hammer

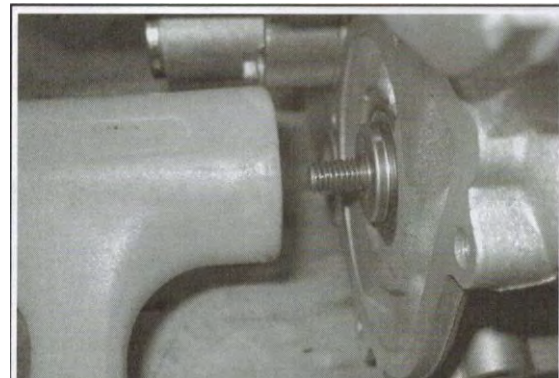

Pull out water pump shaft through the engine drive shaft opening.

NOTE: Pay attention to hold thrust washer to prevent it from falling in crankcase.

1. Thrust washer here

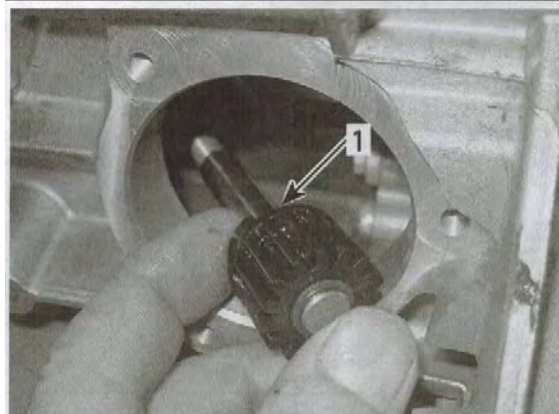

CAUTION: If thrust washer is not on water pump shaft, use a magnet to retrieve it inside crankcase. Using appropriate pliers remove and discard the retaining ring securing water pump gear on water pump shaft.

To remove plastic gear from water pump shaft place gear between your fingers and briskly tap shaft end.



Using 2 screwdrivers, pry out inner part of the rotary seal.



To remove outer part of rotary seal, use an expander from puller kit. Install expander snugly against outer part and pull rotary seal out.

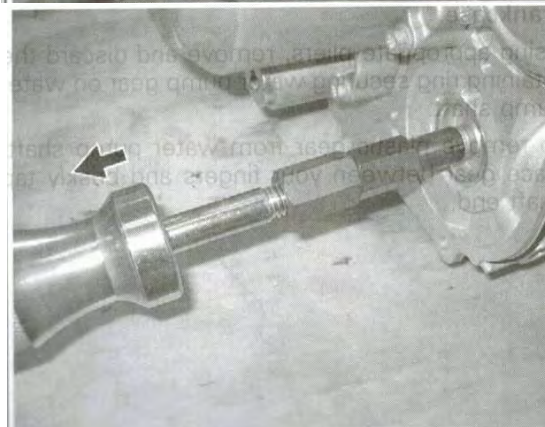

Remove inner oil seal.

1. Inner seal
2. Rotary seal surface

CAUTION: Be careful not to damage the rotary seal surface in crankcase.

Part Inspection

Inspect water pump gear for wear and damage on the snap mechanism to the needle pin. Replace if damaged.

Shaft/Seal Installation

For installation, reverse the removal procedure. However, pay attention to the following.

NOTE: For installation use the torque values. Ensure to use multipurpose grease oil seal.

CAUTION: Always replace rotary seal and water pump shaft together. Also, install a new inner oil seal (behind rotary seal) at the same time.

Apply engine oil on the water pump shaft and intermediate shaft.

NOTE: Never use oil in the press fit area of the oil seal and rotary seal.

Use the oil seal pusher and the installer Handle to install inner oil seal.

1. Handle
2. Pusher

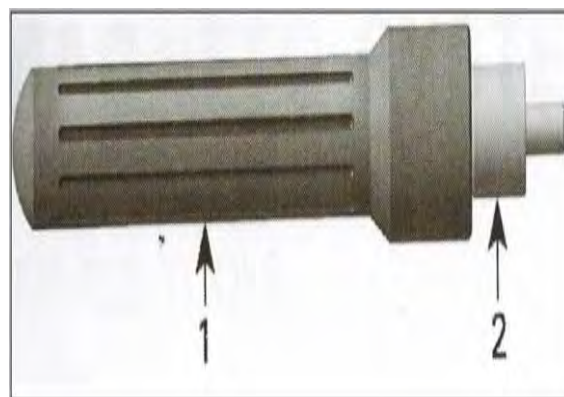
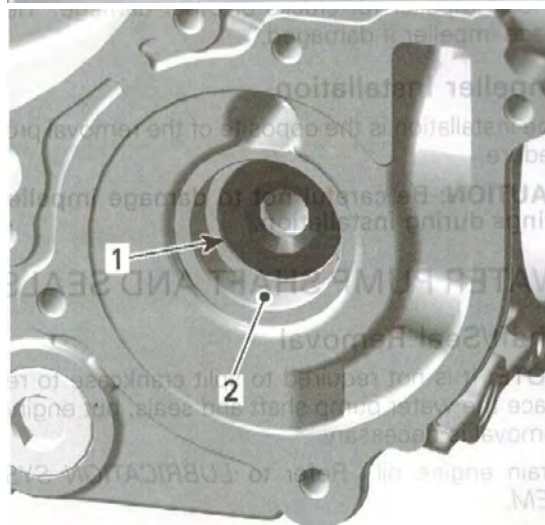

Apply MOLYKOTE inside lips oil seal when installing the oil seal on the pusher, make sure sealing lip points outside.
Push inner oil seal in place.

1. Inner oil seal
2. Installer handle with oil seal pusher

Slide water pump shaft with the new rotary seal into crankcase.

To properly install water pump shaft with rotary seal, use the rotary seal installer.



Use a plastic hammer and drive rotary seal into crankcase.

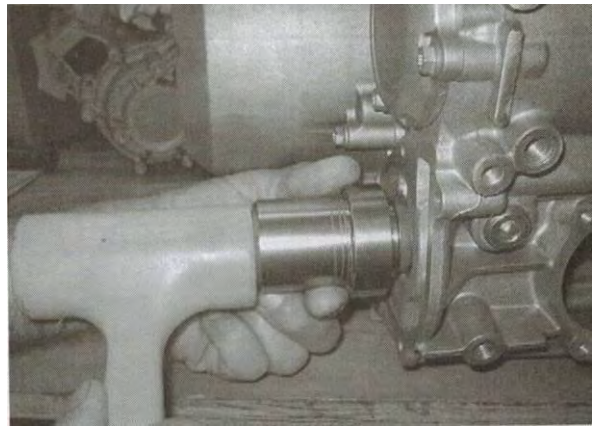

From engine drive shaft opening. Insert thrust washer pump shaft in crankcase.
Using a flashlight and a mirror, position the shaft hole so that pin can be installed.
Position pin between your fingers, push in water pump

shaft to fully expose hole then install pin.
Position pin equal distance out of shaft hole so gear can be installed.
Install water pump shaft gear.

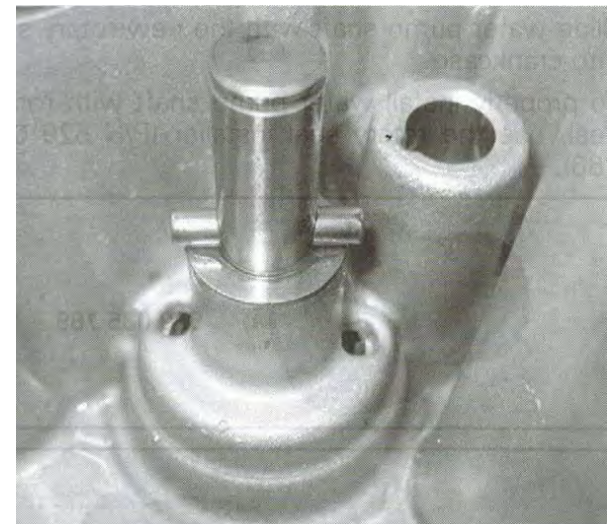

NOTE: Ensure gear properly snaps on pin.
A screwdriver may have to be used to push gear in place.
Use a 45° snap-ring pliers and install a NEW retaining ring on pump shaft end.

CAUTION: Never use the retaining ring a second time. Always install a new one.

After installation, water pump shaft with rotary seal must rotate freely.

Carefully push in water pump gear while turning to mesh with the inner drive gear.

1. Water pump gear
2. Inner drive gear

Tighten Screws of the water pump housing crosswise.

Refill all fluids.

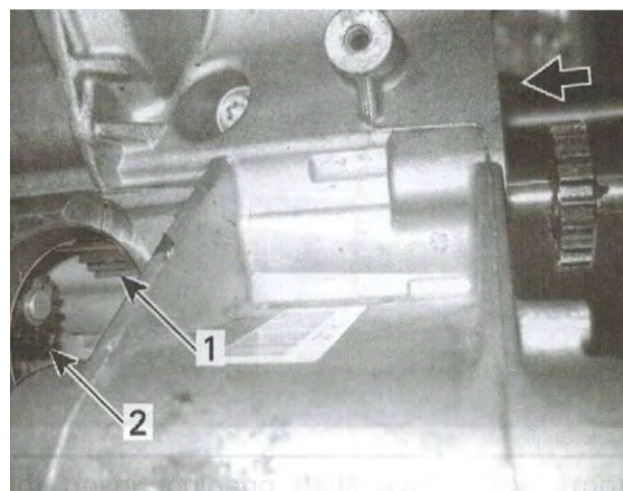

Preparation of tools for routine maintenance of vehicle

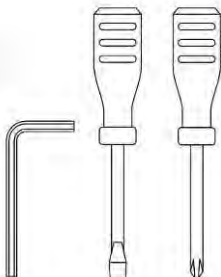
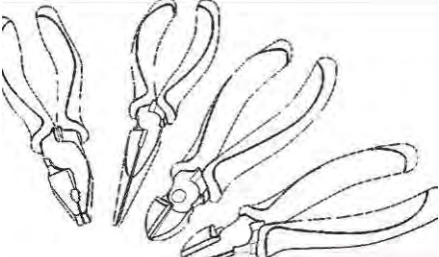
General tool	Name	Operation
	Electronic runner, Spanner	Be use to disassemble and tighten bolts
	Hexagon socket wrench, Screwdriver	Be use to remove cover bolts and screws
	Pliers	Be use to tighten component

V. Vehicle dismantling

External components	5-1	Air inlet and exhaust systems	5-15
Fuel oil system	5-17	Muffler combination	5-21
Gear shift handle and vehicle handle	5-25	Traction engine and water tank combination	5-29
Engine combination	5-31	Rear reducer combination	5-34
Front reducer combination	5-38		

5.1. External components

I. Structure

Figure 5.1.1

Front panel combination

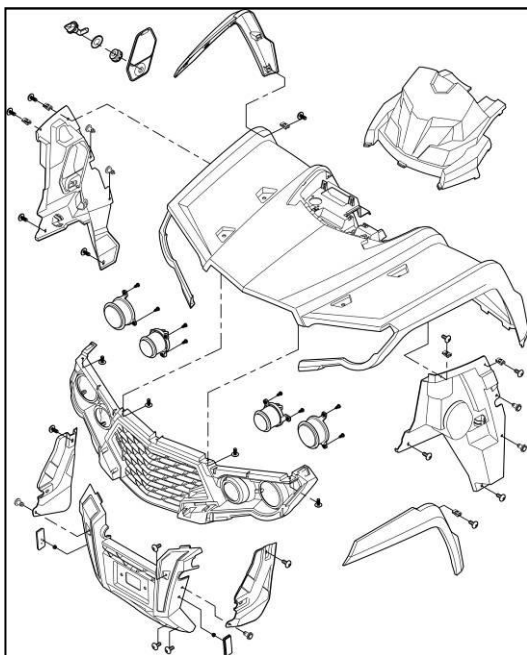

Middle guard board combination

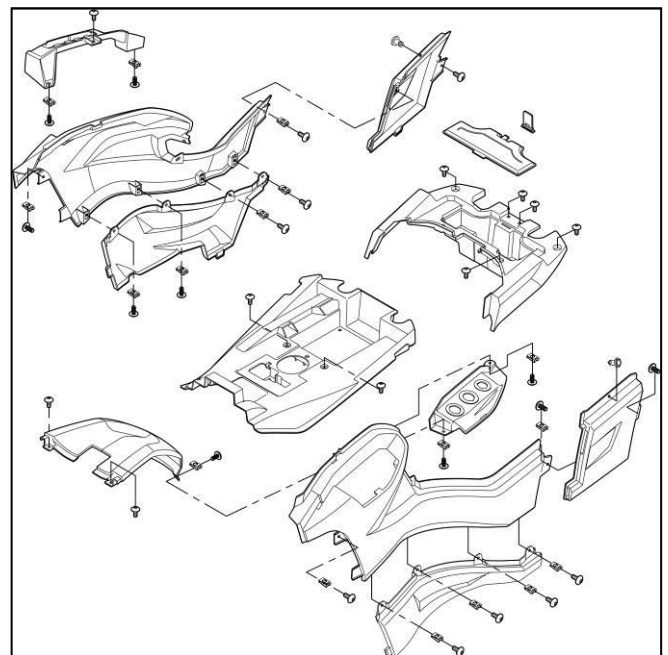

Foot rest combination

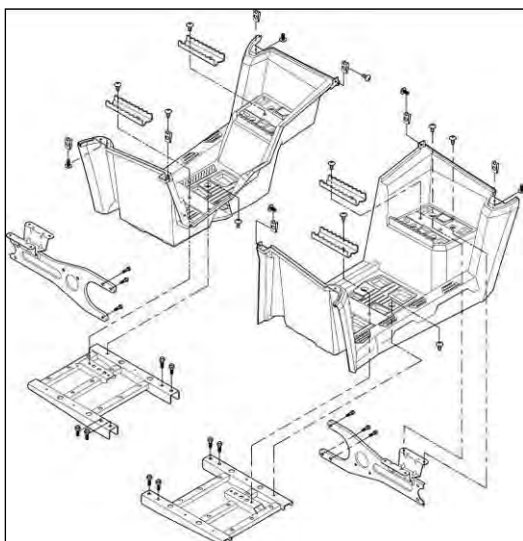

Rear plastic part combination

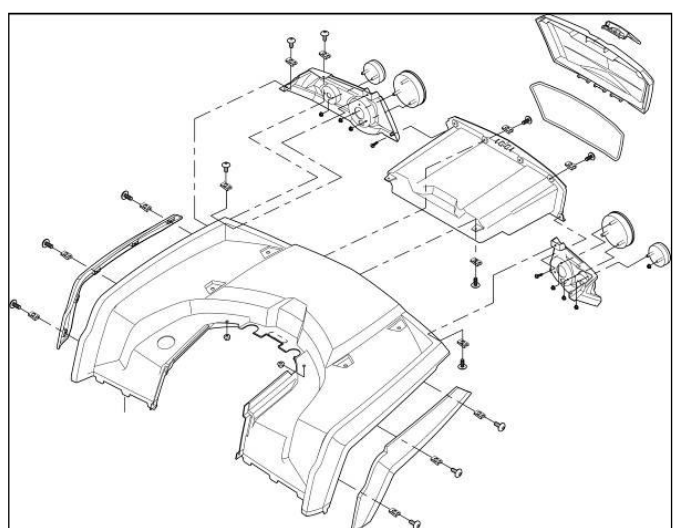

II. Dismantling
Rearview mirror

Figure 5.1.1

Move dust cap upwards, loose two lock nuts of rearview mirror, rotate main body of rearview mirror anticlockwise to remove left and right rearview mirror combination ①.

Tool: 17mm open spanner

Available overhaul: replace rearview mirror

Figure 5.1.1

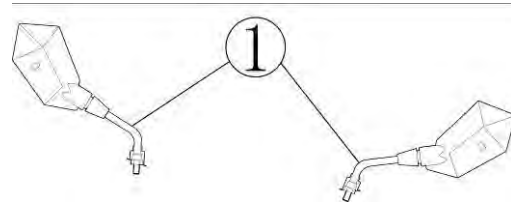

Intermediate shield of handlebar

Figure 5.1.2

Remove one fastening screws and intermediate shield of handlebar.

Available overhaul: replace intermediate shield of handlebar

Figure 5.1.2

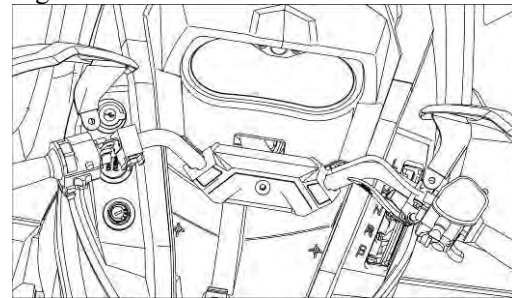

Rear seat

Figure 5.1.3

Place both hands to the back of rear seat, pull left and right lock handle upwards and draw rear seat combination simultaneously.

Available overhaul: replace rear seat

Figure 5.1.3

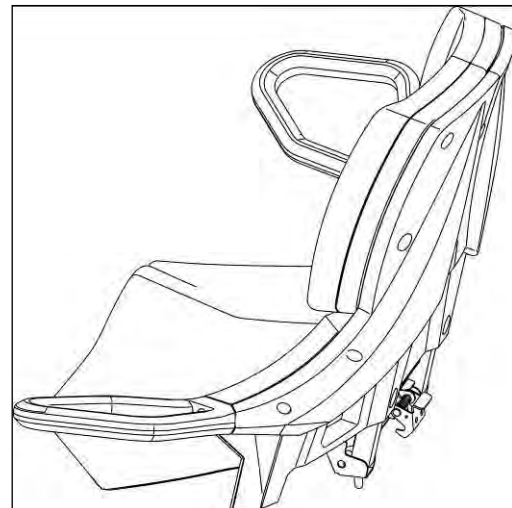

Front seat

Figure 5.1.4

Lift up lock catch at the rear of front seat by the left hand, and pull up and remove front seat by the right hand.

Available overhaul: replace front seat

Available overhaul: replace front seat and battery

Figure 5.1.1.4

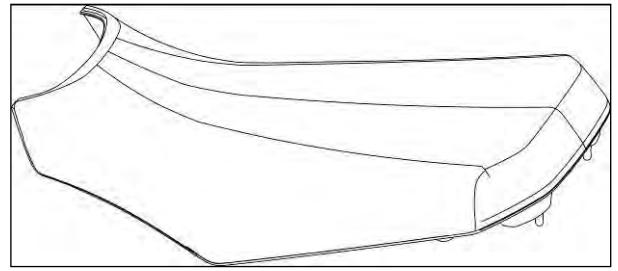

Seat bottom

Figure 5.1.5

Withdrawing battery platen and take out battery, then remove 2 plastic push pin on the both sides of front seat, finally remove correlated bolts. Front and rear seat bottom can be taken out after completion of the previous steps.

Figure 5.1.5

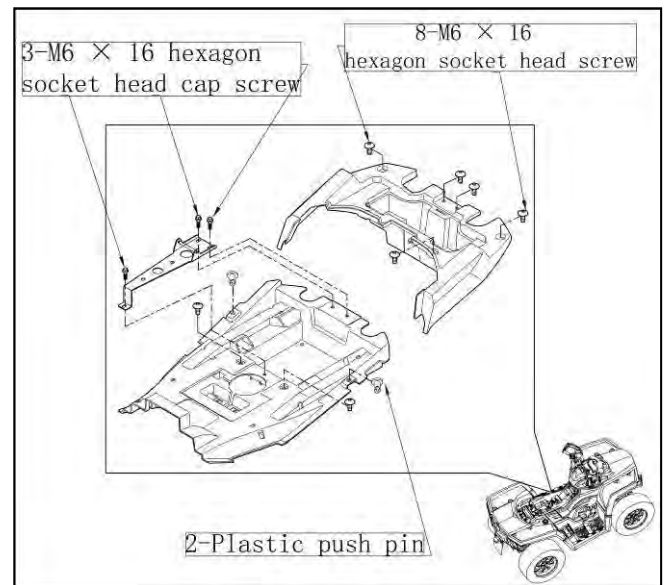

Dash board cover

Figure 5.1.6

Remove dash board cover according to the direction of the arrow (Attention: Dash board cover is not fitted with bolts, so needn't to remove bolts, and strength of dismantling should be controlled by yourself.

Available overhaul: Replace dash board cover

Figure 5.1.6

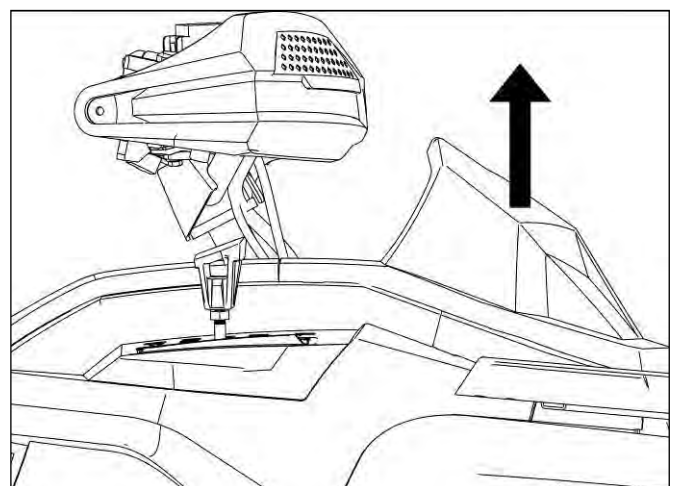

Figure 5.1.7

Remove interior of dash board cover as shown in the figure

Figure 5.1.7

After removing dash board, remove bolts related to auxiliary water tank, radiator cap, relay box and shift controller.

Available overhaul: replace auxiliary water tank, add antifreezing, replace relay.

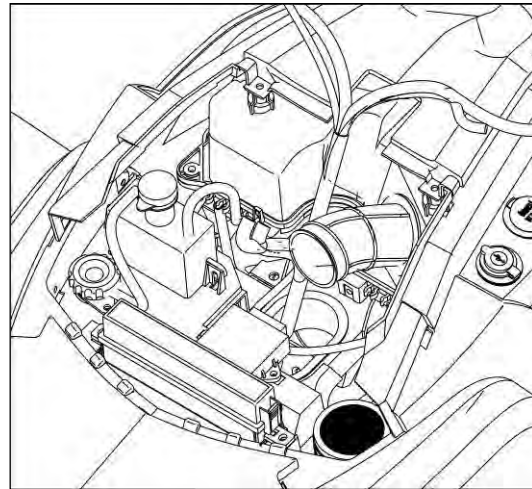

Figure 5.1.8

Mudguard

Figure 5.1.8

Remove two mudguards by the arrow (both sides need to be removed). Remove hoist cover when mudguards are removed.

Available overhaul: replace two mudguards and hoist cover.

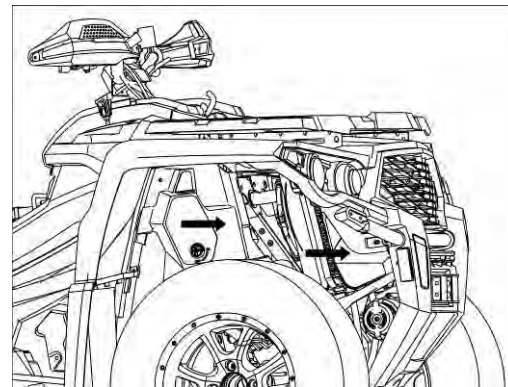

Figure 5.1.9

Rack

Figure 5.1.9

Remove four nuts holding the rack and remove the rack and set aside.(The front and rear shelves are disassembled in the same way)

Available overhaul: Replace rack

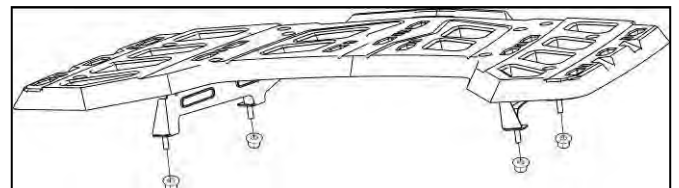

Figure 5.1.10

Front plastic covers combination

Figure 5.1.10

Remove the bolts at the front plastic part and the foot rest , and remove the bolts at the main part of the front plastic part and the frame.Then, the front panel assembly can be removed after pulling out the plug of the electrical components.

Available overhaul:

Replace front plastic covers combination

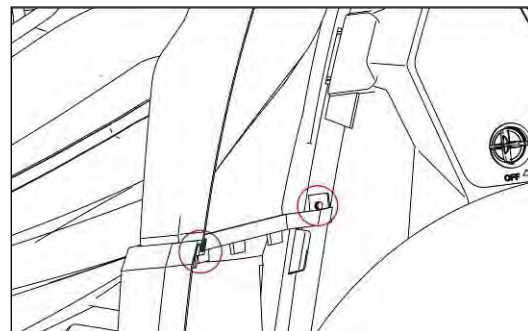

Left and right lateral plates

Figure 5.1.11

Remove one fastening screws of left and right lateral plates

When disassembling the lateral plate on one side, Lift the front and rear three side board up at the same time and then push forward.

Available overhaul: replace left and right lateral plate

Figure 5.1.11

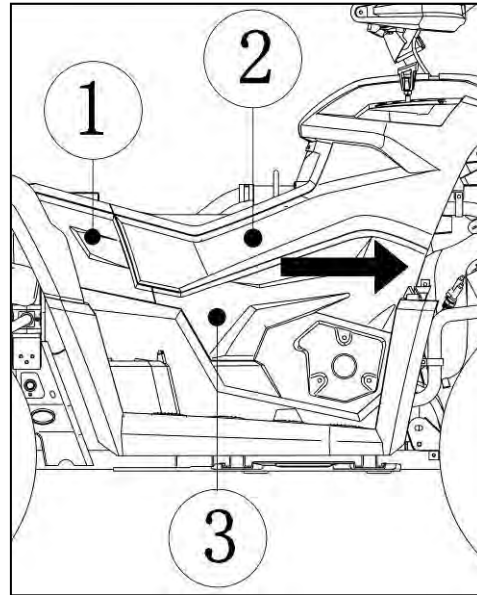

Rear plastic covers combination

Figure 5.1.12

First remove the two bolts between the rear plastic parts and the foot pedal, the bolts under the left and right sides of the container, remove the bolts connected to the frame and the rear plastic parts. After the bolt is removed, pull out the plug of the electrical parts and remove the plastic parts

Available overhaul: Replace rear plastic covers combination

Figure 5.1.12

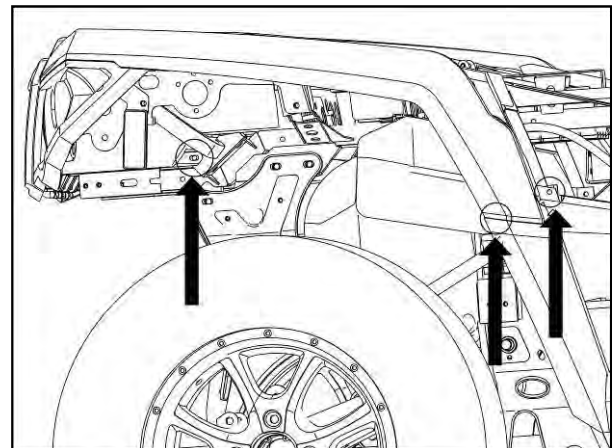

Foot rest

Figure 5.1.13

Remove the 10 bolts fixed between the foot rest and the frame, and remove the foot rest from the frame after removal.

Available overhaul: **Replace foot rest**

Figure 5.1.13

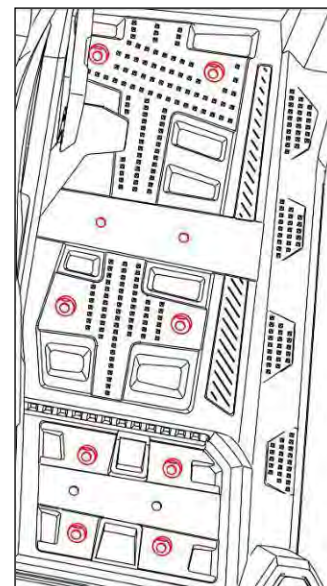

5.2. Air inlet and exhaust system

I. Structure

Figure 5.2.1

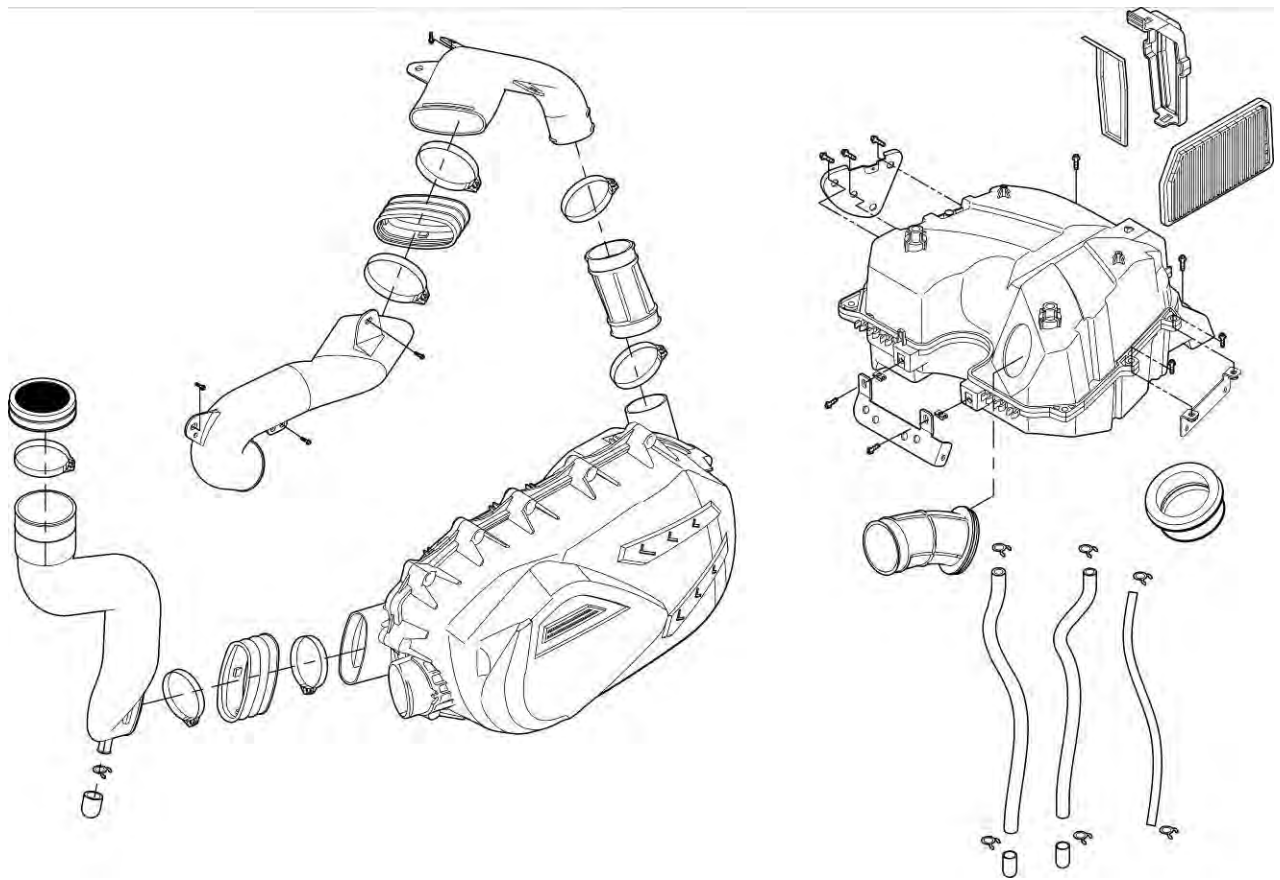

1. CVT intake and outlet system

2. Air filter combination

II. Dismantling

CVT air inlet pipe combination

Figure 5.2.2

Loosen the bolts of the three clamps of the CVT air inlet pipe combination at one time. After loosening, maintenance and replacement of relevant parts can be carried out.

Available overhaul: replace CVT exhaust pipe combination

Figure 5.2.2

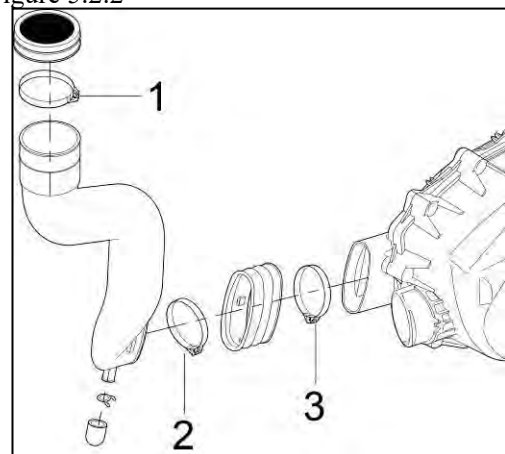

CVT exhaust pipe combination

Figure 5.2.3

Remove the bolt No. ① and loosen the clamp No. ②. Then, the relevant components of exhaust pipe combination can be maintained

Available overhaul: replace CVT air inlet pipe combination

Figure 5.2.3

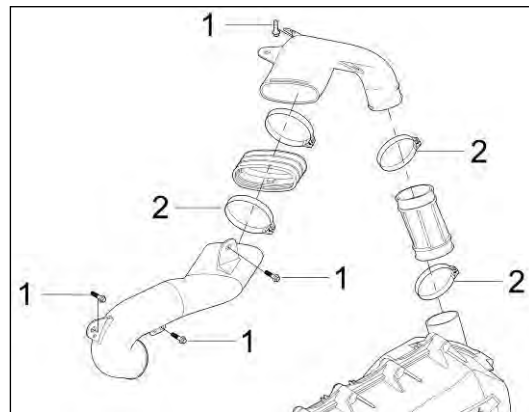

Air filter combination

Figure 5.2.4

First loosen the clamp① between the throttle valve and the air filter, then remove the four bolts② connecting the air filter and the frame, and finally remove the shift arm. Complete the above steps to maintain the air filter

Air filter element combination

Figure 5.2.5

Remove the cover ①of the air filter element, and then pull out the filter element in the direction of the arrow. The filter element can be cleaned or replaced after removal.

Available overhaul:

Replace and conduct daily maintenance of air filter combination

Figure 5.2.4

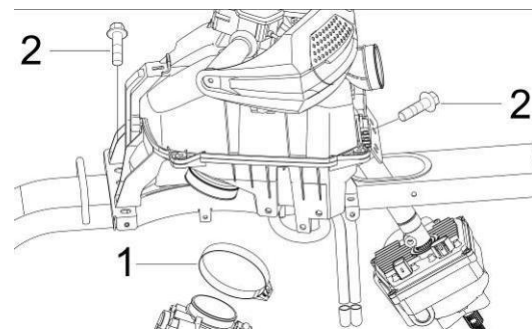
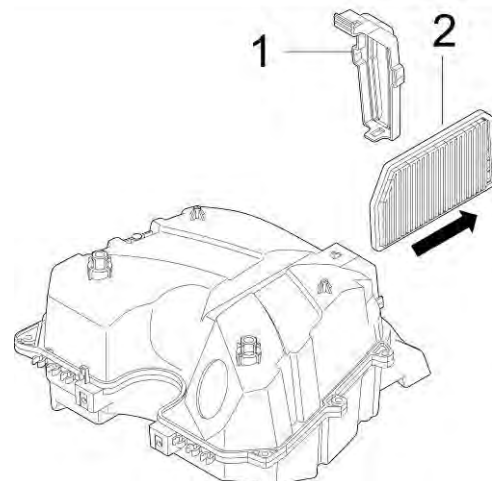

Figure 5.2.5



5.3. Fuel oil system

I. Structure

Figure 5.3.1

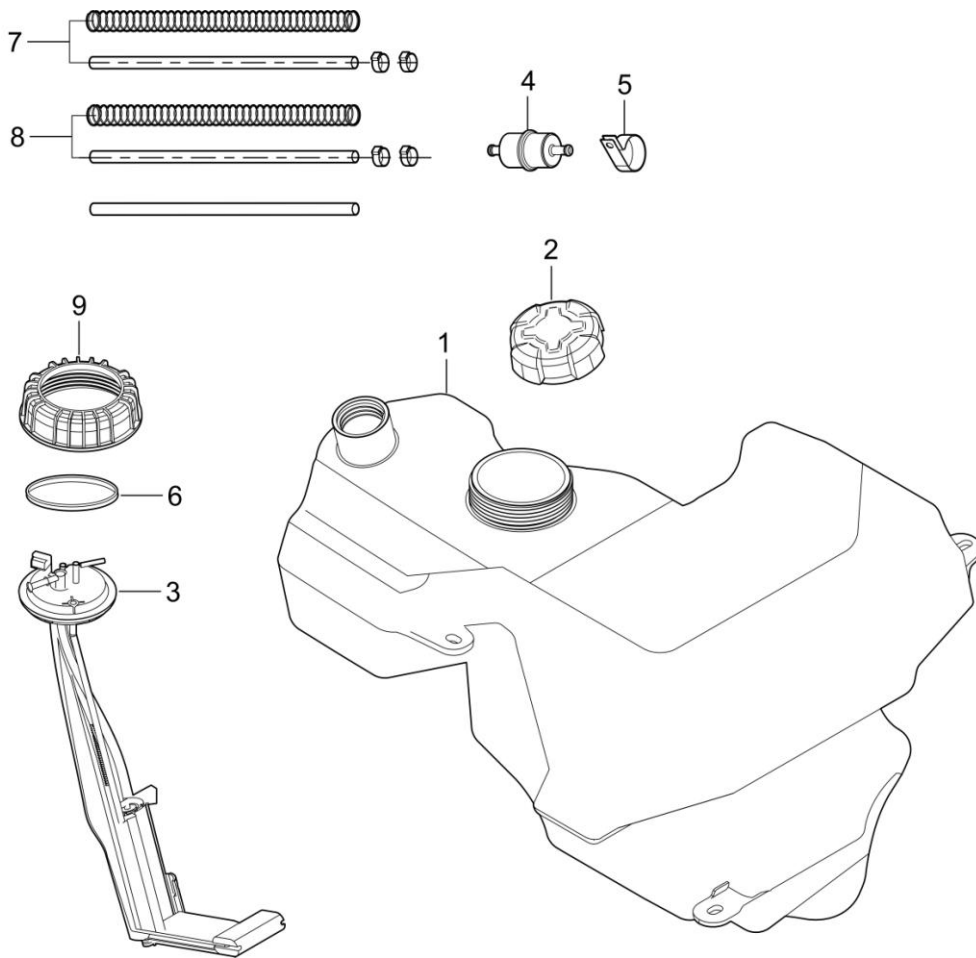

Names of components:

- | | | | | |
|--------------------------|--------------------------------------|-------------------------------------|------------------------------|----------------------------|
| 1. Fuel tank combination | 2. Fuel tank cover | 3. Fuel pump combination | 4. Fuel filter | 5. Gasoline filter support |
| 6. Seal ring | 7. Cylinder II fuel pipe combination | 8. Cylinder I fuel pipe combination | 9. Fuel pump cap combination | |

II. Dismantling

Fuel tank combination

Figure 5.3.2

Disconnect wire group plug-in of fuel sensor, separating fuel sensor from wire group. Note: Do not pull the plug directly when you pull it out. Press the plug by hand and pull it out at both ends.

Warning: special attention should be paid to explosive gasoline

Figure 5.3.2

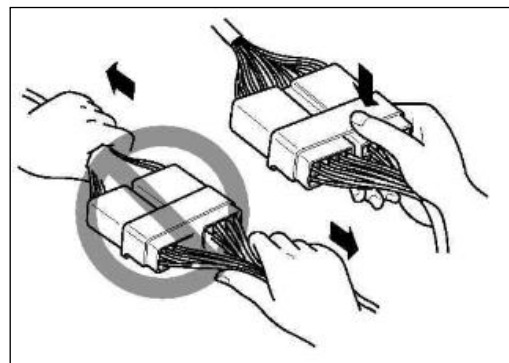

Figure 5.3.3

Unplug the tubing and tank vent after releasing the hose clamp, and then rotate the oil pump cap in the direction of the arrow. After completing the above steps, the oil pump can be removed from the tank for repair or replacement.

Note: ear clamp should not be used repeatedly; new clamp should be used upon installation. When pulling out fuel pipe, attention should be paid to pressure inside fuel pipe, splash proof measures should be taken and vessel should be prepared to discharge fuel inside fuel pipe in advance.

Figure 5.3.3

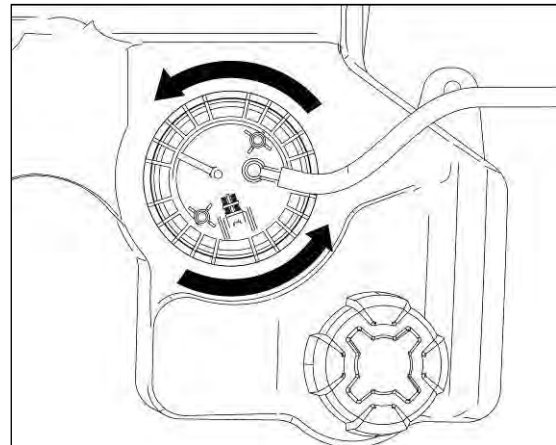

Figure 5.3.4

Loose the clamp below the throttle valve, unplug the relevant connector, and remove the throttle valve from the body for maintenance. Unplug the high voltage coil and remove the spark plug with a tool. Available overhaul: Replace and conduct daily maintenance of spark plug

Figure 5.3.4

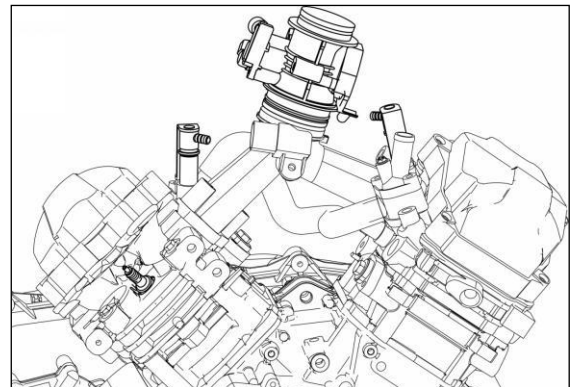

Figure 5.3.5

After removing the screw with a screwdriver, open the throttle valve cover and remove the pin of the throttle cable head from the throttle cable. Then separate the throttle cable and throttle valve. Available overhaul: Replace and conduct daily maintenance of throttle valve combination and accelerator cable combination

Figure 5.3.5

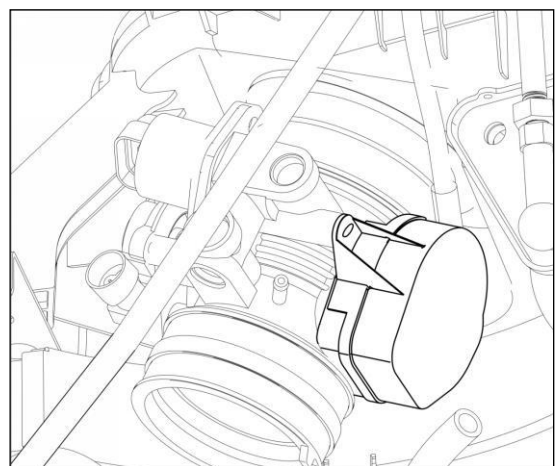

Figure 5.3.6

Disconnect cylinder I fuel nozzle, crankshaft position sensor and stepping motor plug-in separately.
Remove the hose clamp 14.5mm and pull out the two fuel hose connected to the fuel injector
Available overhaul:
Replace and conduct daily maintenance of fuel pipe

Fuel pipe combination

Figure 5.3.6

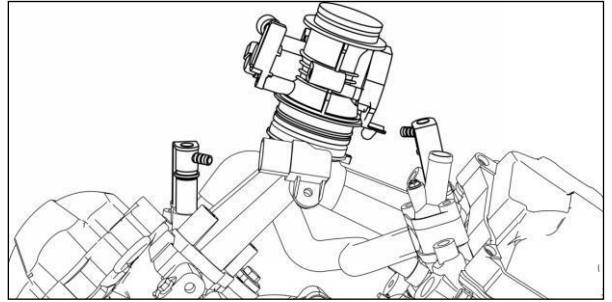

Figure 5.3.7

Remove one screws, fuel filter support and fuel filter. one end of filter boss faces cylinder head upon installation.

Note: ear clamp should not be used repeatedly; new clamp should be used upon installation.

After completing dismantling fuel system, check fuel pipe, fuel filter and fuel pump filter element for block and crack. Replace the component with a new one, if necessary.

Figure 5.3.7

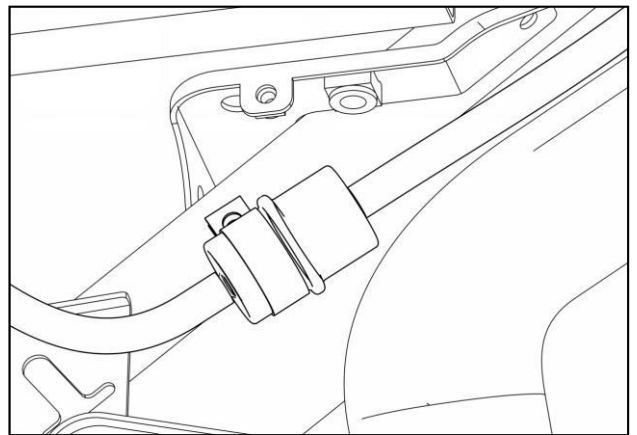

Re-installation

Conduct re-installation based on reversed sequence of dismantling.

Warning:

To prevent fuel leakage, seal gasket, O-ring and ear clamp should be replaced upon re-installation.

Fuel pipe should be replaced once every two years.

Do not smoke or near an open flame when performing maintenance on the fuel system

5.4. Muffler combination

I. Structure

Figure 5.4.1

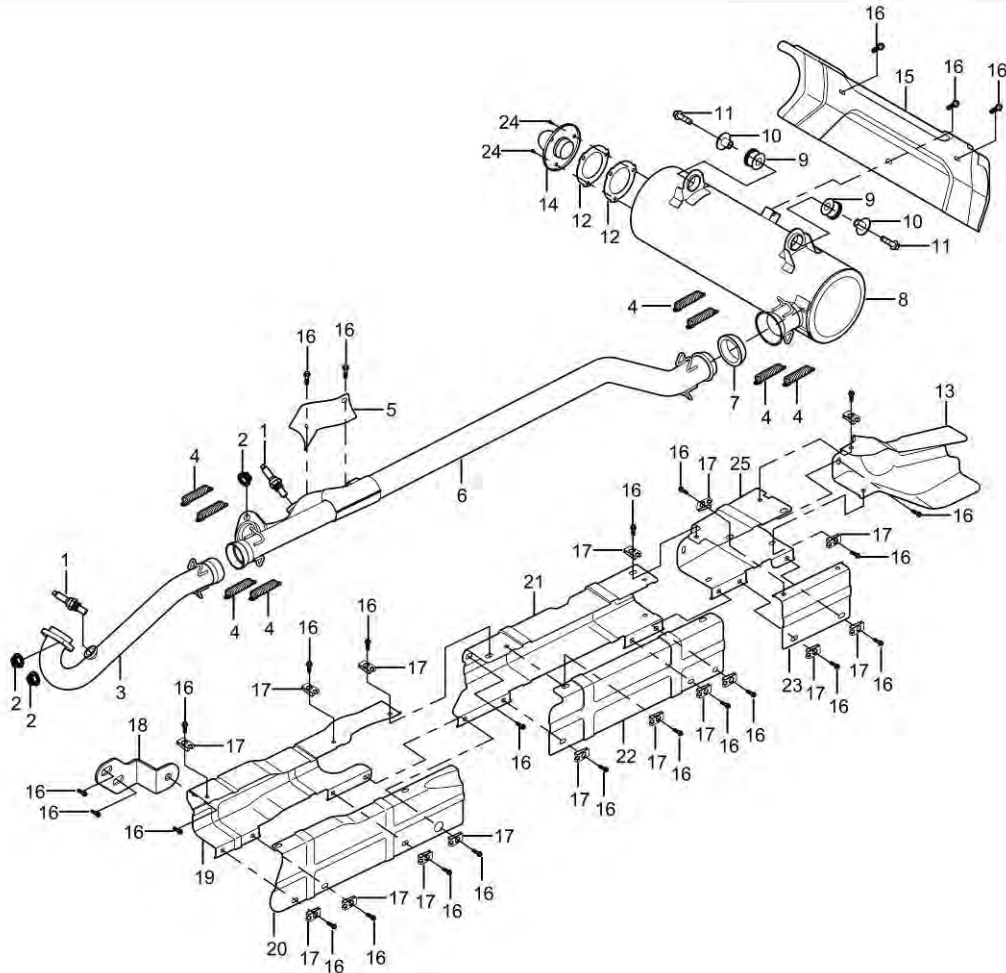

Names of components:

- | | | |
|---|---|--|
| 1. O2 sensor | 2. Locking Nut | 3. Front Exhaust Pipe |
| 4. Spring | 5. Rear Cylinder Exhaust Pipe Insulation Board | 6. Rear Exhaust Pipe |
| 7. Graphite Seal Cartridge | 8. Muffer tube | 9. Muffer Hang Rubber Sleeve |
| 10. Muffer Hang Neck Bushing | 11. M8Hex Flange Bolt | 12. Graphite shim |
| 13. Front muffer protection | 14. Rear exhaust combination | 15. Muffer tube guard board |
| 16. M6 Hex Flange Bolt | 17. Splint nut | 18. Heat protection mounting bracket |
| 19. Front Cylinder Exhaust Pipe Insulation Board (Inner) | 20. Front Cylinder Exhaust Pipe Insulation Board (Outer) | 21. Rear Cylinder Exhaust Pipe Insulation Board (Rear) |
| 22. Rear Cylinder Exhaust Pipe Insulation Board (Front) | 23. Middle Cylinder Exhaust Pipe Insulation Board (Outer) | 24. Flanged head screw |
| 25. Middle Cylinder Exhaust Pipe Insulation Board (Inner) | | |

II. Dismantling

Figure 5.4.2

Separate the oxygen sensor from the front exhaust pipe and the rear exhaust pipe, and then separate the O2 sensor from the connector of the main cable
(Refer to relevant contents in section I of the chapter for dismantling vehicle plastic parts)

Figure 5.4.2

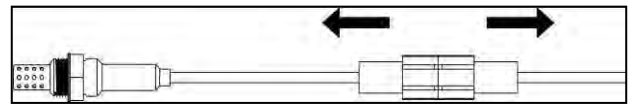

Figure 5.4.3

Remove the 3 exhaust pipe covers as shown on the right, 15 bolts in total.

Figure 5.4.3

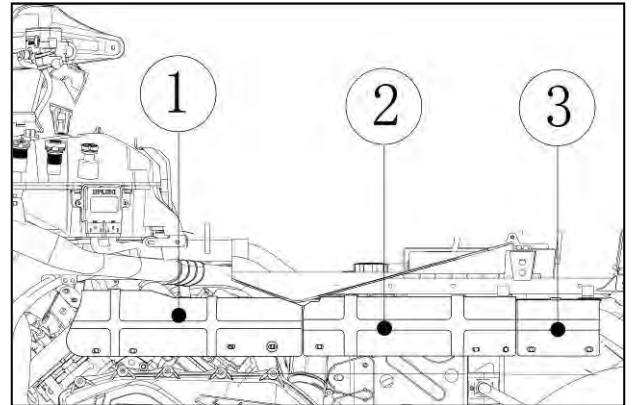

Figure 5.4.4

First remove the tension springs on the hook (remove all four springs at the rear exhaust pipe at the same time), then remove the two bolts at the upper end of the muffler, finally remove the muffler and graphite seal gasket according to the direction of the arrow.

Available overhaul: Maintenance and replacement of muffler

Figure 5.4.4

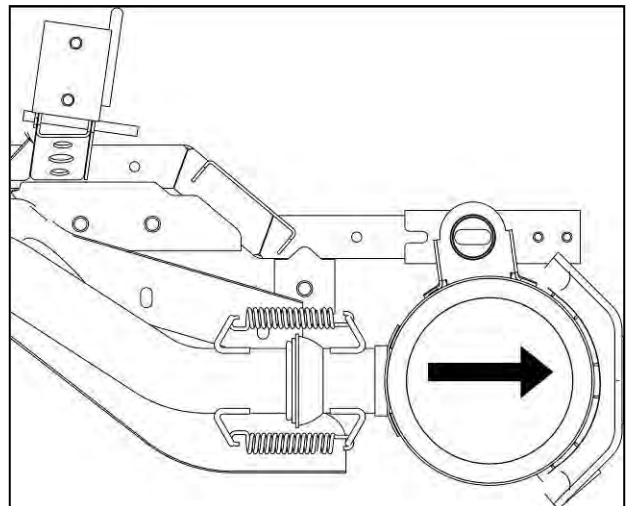

Figure 5.4.5

First, loosen the cover of the rear exhaust pipe, then remove the two M8 lock nuts of the rear exhaust pipe, and finally remove the rear exhaust pipe from the vehicle

Finally, remove the two M8 locking nuts of the front exhaust pipe and remove the front exhaust pipe from the vehicle.

Figure 5.4.5

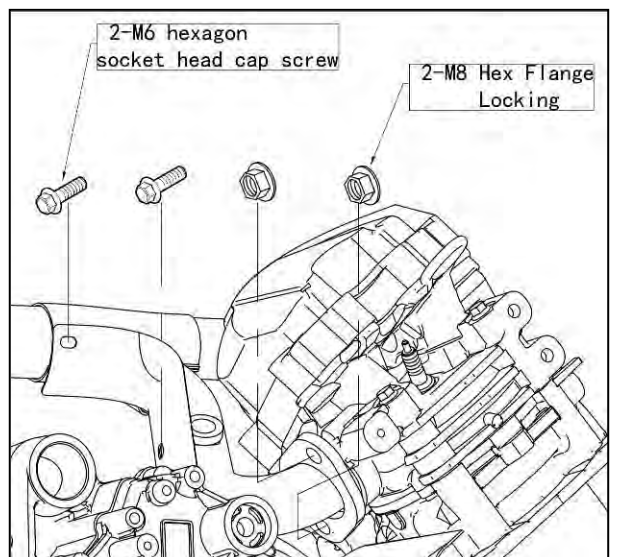

Figure 5.4.6

Remove the four heat insulation plate (short type without heat insulation plate No. 3) on the inside of the exhaust pipe, a total of 10 M6 hex flange bolts.

Available overhaul:

Replace and conduct daily maintenance of cylinder I exhaust pipe

Figure 5.4.7

Remove muffler trim cover, total 4 M6 hex flange bolts. Remove 3 countersunk allen screw on muffler tail cover.

Available overhaul:

Daily maintenance of muffler

Re-installation

Conduct re-installation based on the reversed sequence of dismantling.

Warning:

After dismantling muffler, seal gasket of exhaust pipe should not be used repeatedly; new component should be used upon installation.

To prevent exhaust pipe leakage, high polymer sealant should be applied to cylinder I exhaust pipe port and surface of exhaust pipe seal gasket upon muffler assembly installation.

Figure 5.4.6

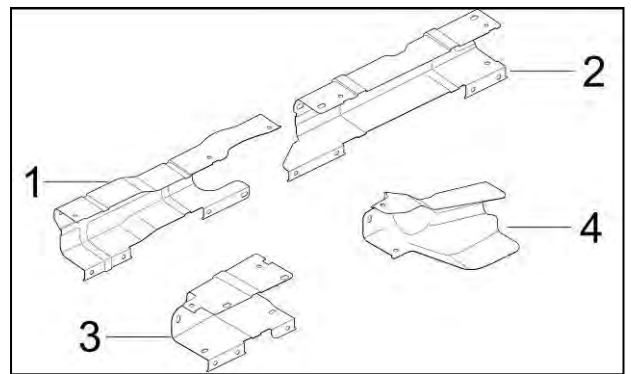
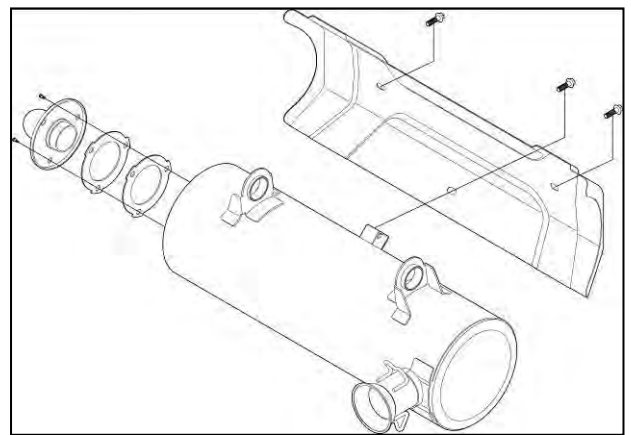

Figure 5.4.7



5.5. Gear shift handle and handlerbar combination

I. Structure

Figure 5.5.1

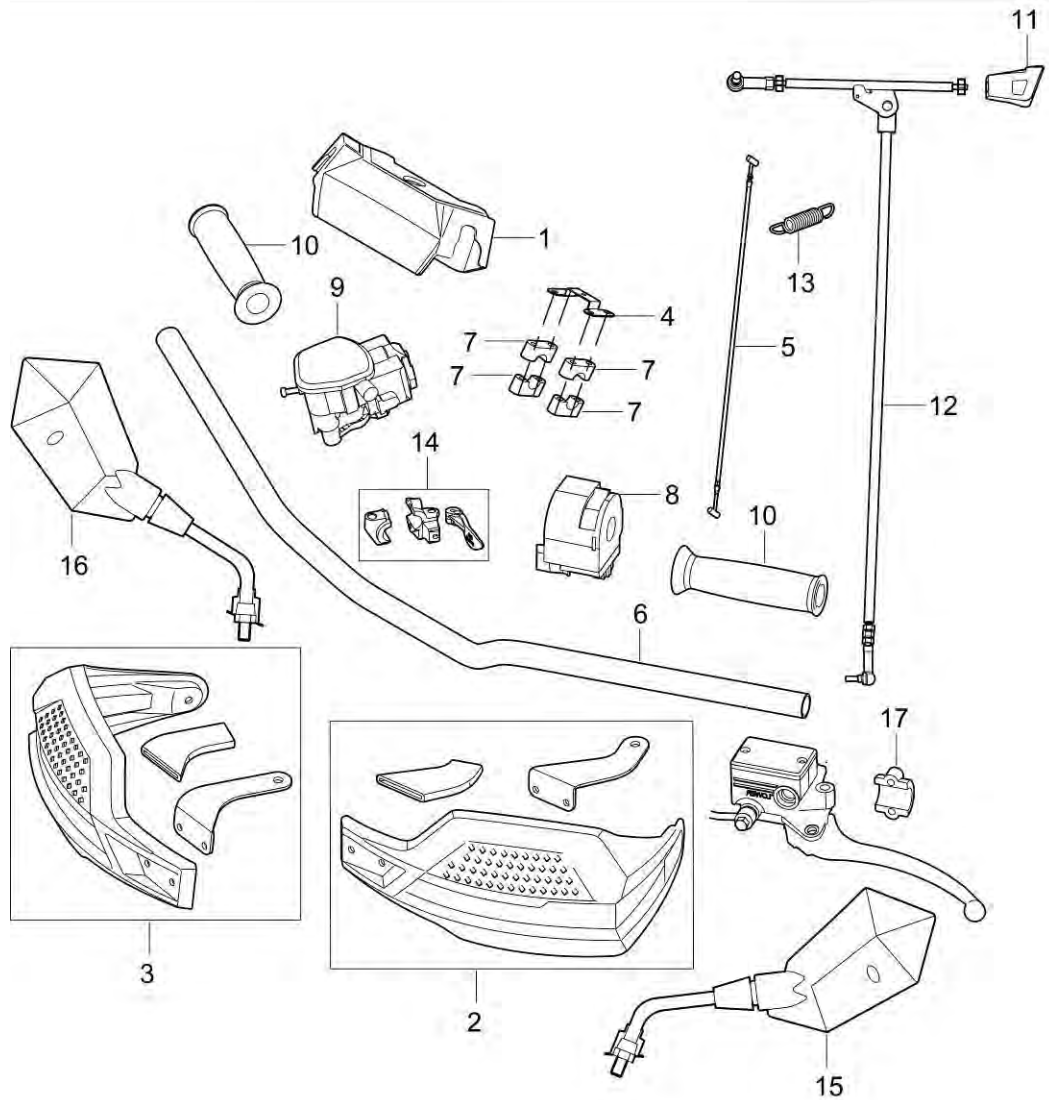

Names of components:

- | | | | |
|-------------------------------------|--------------------------------------|---------------------------------------|--|
| 1. Intermediate shield of handlebar | 2. Left handlebar shield combination | 3. Right handlebar shield combination | 4. Positioning plate of intermediate shield of handlebar |
| 5. Accelerator cable | 6. Handlebar bend | 7. Handlebar hold-down block | 8. Combination switch |
| 9. Fuel charger | 10. Handle grip | 11. Gear shift ball | 12. Gear shift handle |
| 13. Gear shift tension spring | 14. Parking combination handle | 15. left rear view mirror | 16. right rear view mirror |
| 17. Grip brake block | | | |

II. Dismantling

Gear shift handle combination

Figure 5.5.2

Remove lock nut of gear shift handle on the right side of a vehicle.

Remove gear shift tension spring, separating the upper part of gear shift handle combination from a vehicle.

(Refer to relevant contents in section I of the chapter for dismantling vehicle plastic parts)

Figure 5.5.2

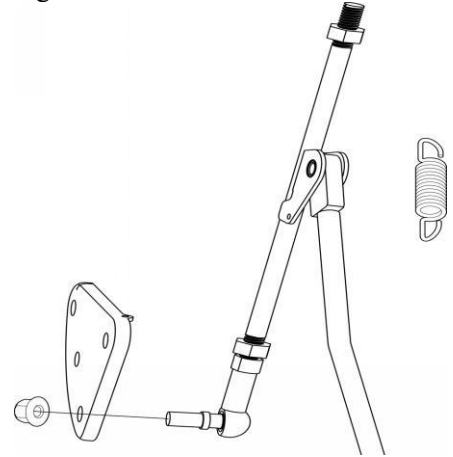

Figure 5.5.3

Remove lock nut of gear shift handle combination at gear shift rocker arm before removing gear shift handle combination.

Available overhaul:

Replace gear shift handle combination

Figure 5.5.3

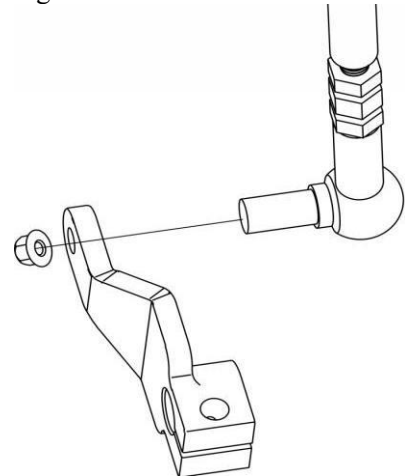
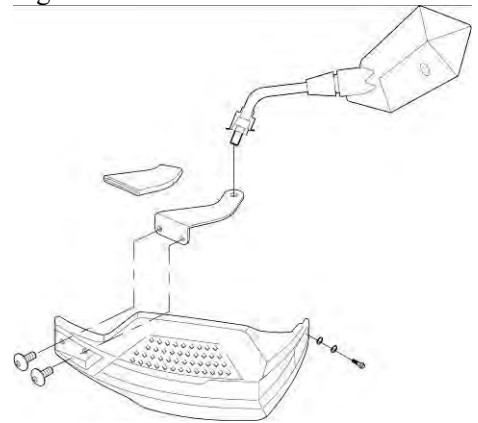

Figure 5.5.4

Handlebar combination

Figure 5.5.4

First remove the left rear view mirror and then remove the 3 bolts on the handlebar guard.(Remove the right hand in the same way)



5. VEHICLE DISMANTLING

Figure 5.5.6

Remove three screws and upper cover of fuel charger. Separate the throttle cable

Available overhaul:

Replace and adjust accelerator cable and manual brake master cylinder

Figure 5.5.6

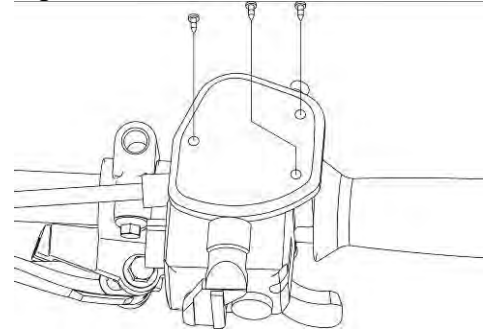

Figure 5.5.7

Remove two screws and fuel charge combination .

Available overhaul:

Replace fuel charge combination

Figure 5.5.7

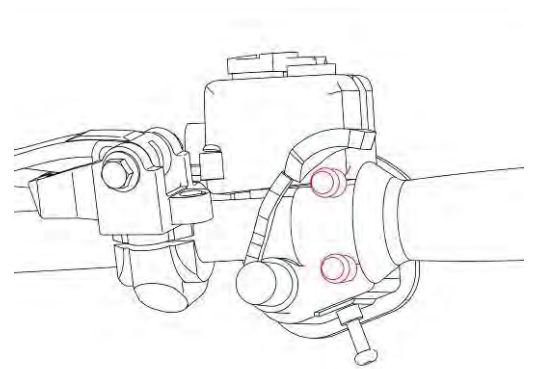

Figure 5.5.8

Remove four screws and relay shield of traction engine.

Figure 5.5.8

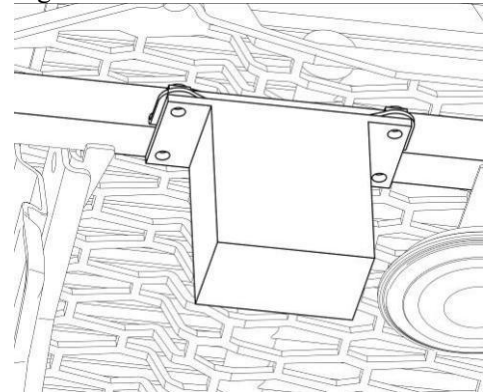

Figure 5.5.9

Remove four electrode lock nuts of traction engine relay, separating positive and negative electrode ① of traction engine, positive and negative cable ② of battery from wire group.

Figure 5.5.9

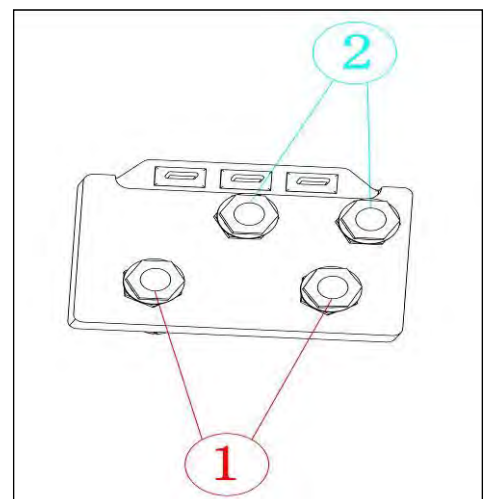

Figure 5.5.10

Disconnect switch plug-in ③ of traction engine and remove relay assembly ④ of traction engine.

Available overhaul:

Replace and test relay assembly of traction engine.

Figure 5.5.10

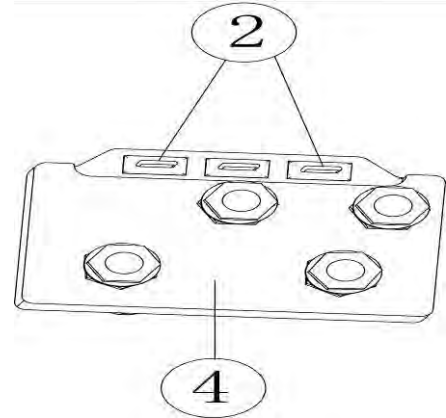

Figure 5.5.11

Remove the two bolts numbered 1 to remove the winch switch, and remove the bolts numbered 2 to remove the winch switch bracket.

Available overhaul:

Replace and test control switch and combination switch of traction engine

Figure 5.5.11

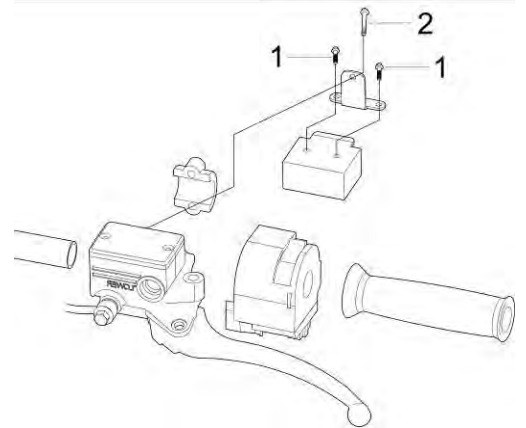
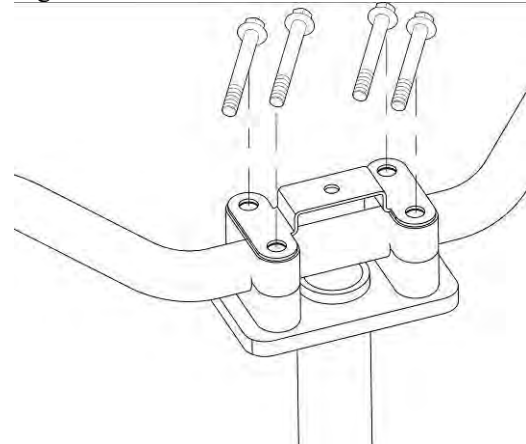

Figure 5.5.12

Remove four screws, positioning plate of handlebar intermediate shield, handlebar hold-down block and handlebar combination (include left and right handlebar grip), completing dismantling handlebar combination.

Figure 5.5.12



Re-installation

Conduct re-installation based on reversed sequence of dismantling.

5.6 Traction engine and water tank combination

I. Dismantling

Figure 5.6.1

Rotate control handle of traction engine clockwise , releasing lock-up status of cable. Pull out cable for about 30cm along .

Figure 5.6.1

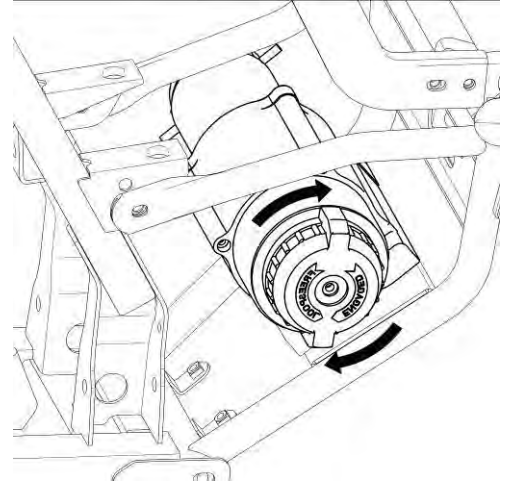
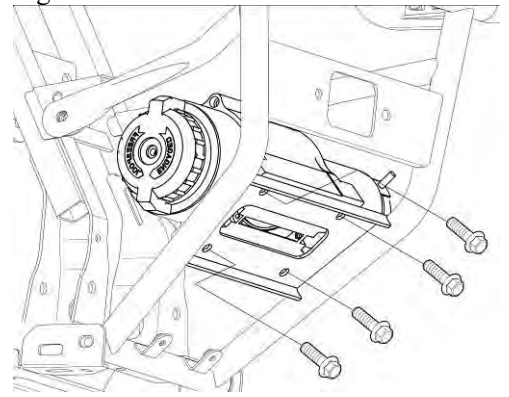

Figure 5.6.2

First remove the hoist cover, and then remove the four fixed bolts at the bottom of the hoist, pull out the relevant connector and cable, and finally remove the hoist for routine maintenance

Figure 5.6.2



Available overhaul:

Replace traction engine main body and cable guide combination

Figure 5.6.3

Water tank

Figure 5.6.3

Disconnect temperature sensor plug-in ① of water tank, separating it from water tank.

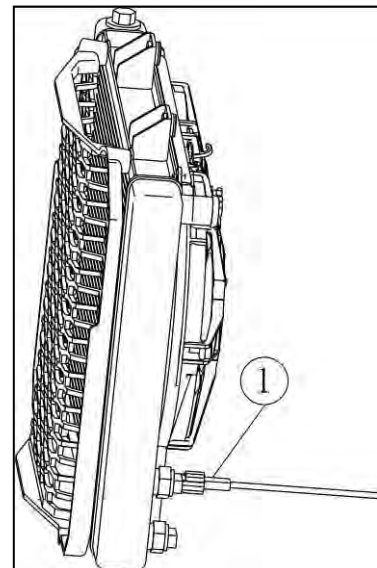

Figure 5.6.4

Prepare a clean container (capacity?) and place it under the vehicle.

Remove water inlet pipe clamp of cylinder head and outlet water pipe clamp of engine, separating inlet water pipe ① of cylinder head and outlet water pipe ② of engine from vehicle, and leading coolant inside pipe to prepared container.

(Refer to relevant contents in section I of the chapter for dismantling vehicle plastic parts)

Figure 5.6.5

Remove clamp ④ of water tank cover, pull out water pipe ⑤ of water tank and plug pipe port to prevent leakage.

Remove two screws, separating water tank cover ⑥ and vehicle.

Figure 5.6.6

Remove two screws and auxiliary water tank combination ⑦ (include water pipe and clamp).

Available overhaul:

Replace auxiliary water tank

Figure 5.6.7

Remove two screws and water tank combination ⑧, completing dismantling water tank combination.

Available overhaul:

Replace and check water inlet and outlet pipe and water tank cover

Replace and check water tank

Re-installation

Conduct reinstallation based on reversed sequence of dismantling.

Figure 5.6.4

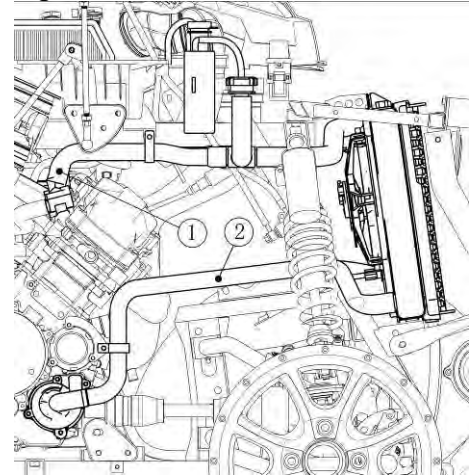

Figure 5.6.5

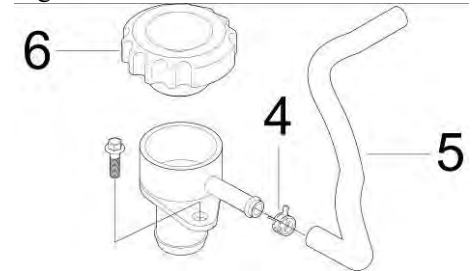

Figure 5.6.6

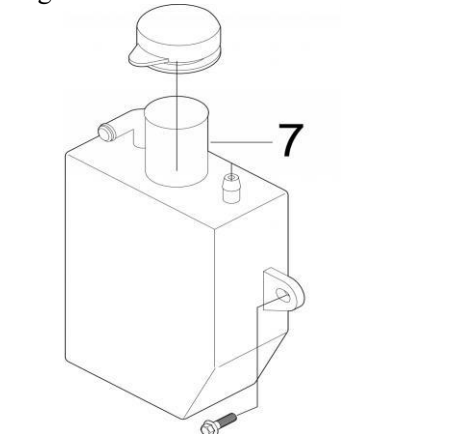
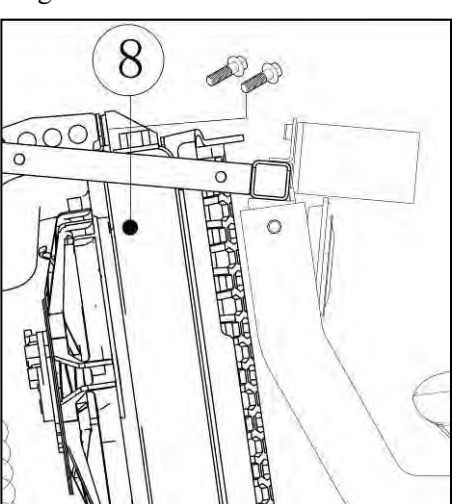

Figure 5.6.7



5.7. Engine combination

I. Dismantling

Foot brake master cylinder combination

Figure 5.7.1

Remove the two installing bolts of the main brake pump and then remove the foot brake rest. Finally, remove the four fixed bolts of the main pump bracket and take out the injector pump bracket
(Refer to relevant contents in section I of the chapter for dismantling vehicle plastic parts)

Tightening bolt torque of foot brake master cylinder: 24-28 N.m

Figure 5.7.2

Remove two screws and brake oil cup combination .

Available overhaul:

Check oil cup level and replace oil cup

Engine

Figure 5.7.3

Disconnect the speed sensor plug on the engine and the gear display cable, disconnect the oil pressure sensor plug, and disconnect the engine wiring harness from the main harness. Disconnect the engine harness. (Installation should follow position indicated in figure corresponding to gear line tag serial number! Random connection is not allowed to avoid gear indication out of order)

Figure 5.7.1

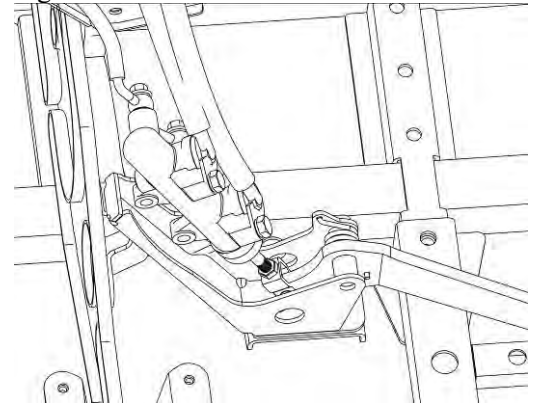

Figure 5.7.2

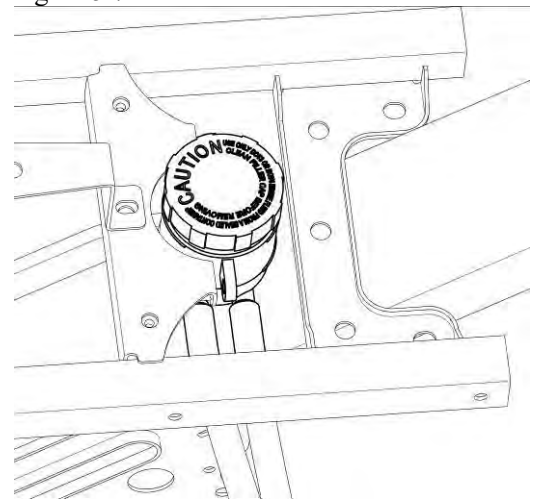

Figure 5.7.3

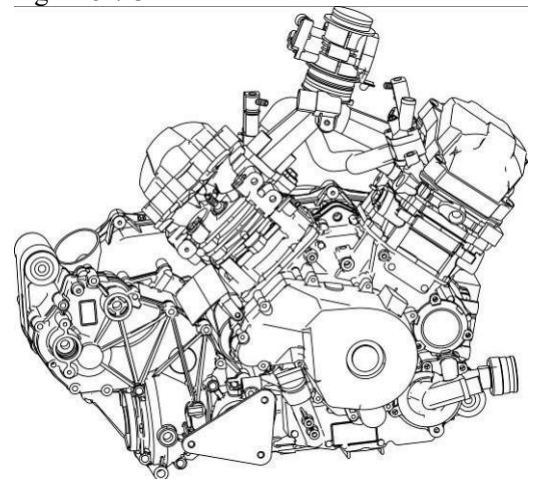

Figure 5.7.4

Remove three screws and engine hanging combination .

Tightening torque of engine hanging bolt: 60-65 N.m

Figure 5.7.4

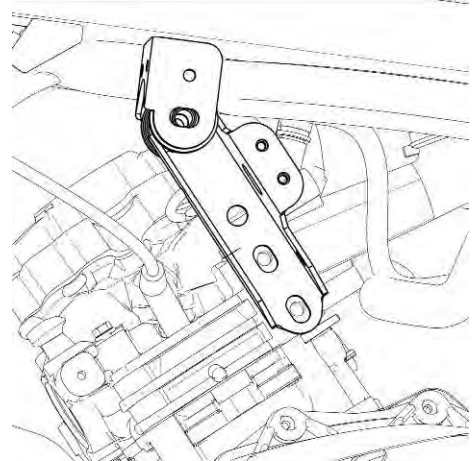

Figure 5.7.5

Remove one fixing screw of vehicle in the front of engine.

Tightening screw torque of front transmission shaft: 70-80 N.m

Tightening screw torque of engine: 60-65 N.m

Figure 5.7.5

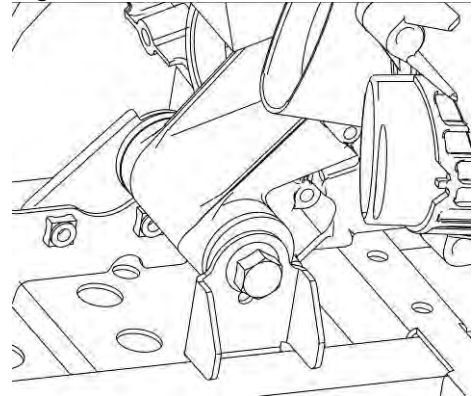

Figure 5.7.6

Remove three fixing screw of vehicle behind engine.

The front and rear drive shafts are connected by splines. After the engine fixing bolts are removed, the front and rear drive shafts can be directly released from the splines.(Rear drive shaft and engine can not be separated)

Tightening screw torque of vehicle behind engine: 60-65 N.m

Figure 5.7.6

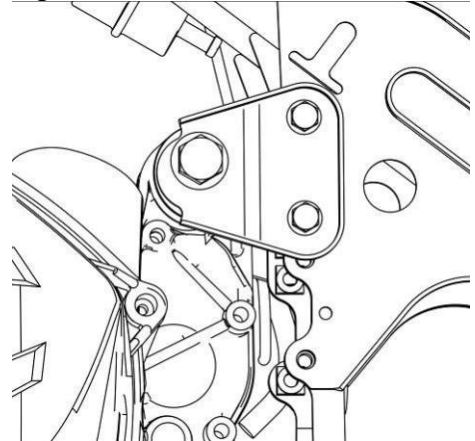
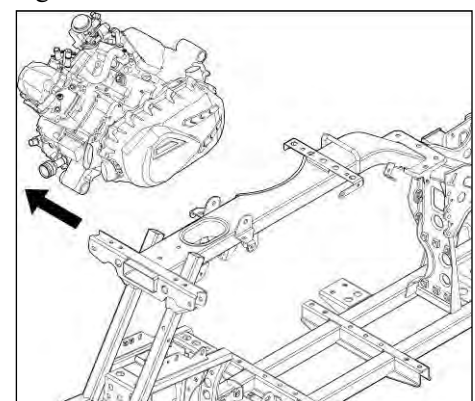

Figure 5.7.7

After the engine bolts are removed, check whether there are any plugins forgotten to remove, and finally lift the engine and rear transmission shaft from the right side of the frame.

Figure 5.7.7



5.8. Rear retarder combination

I. Dismantle the left side

(Left and right disassembly steps are the same, and the process is carried out at the same time)

Figure 5.8.1

First place intermediate part of vehicle to a dedicated support, leaving front and rear wheels of a vehicle in suspended status.

Remove four nuts, pull along axial direction and remove rear wheel combination.

Figure 5.8.1

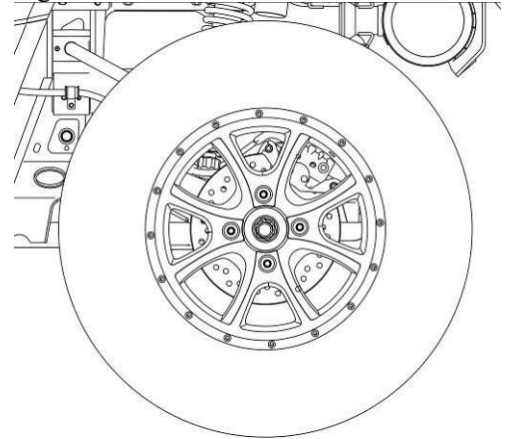

Tightening torque of rear wheel nut: 70-80 N.m

Available overhaul: replace rear wheel combination

Figure 5.8.2

Place transmission case gear to "P", leaving left and right semi-axis in lock-up status.

Remove split pin and lock nut of rear semi-axis on the left side.

Figure 5.8.2

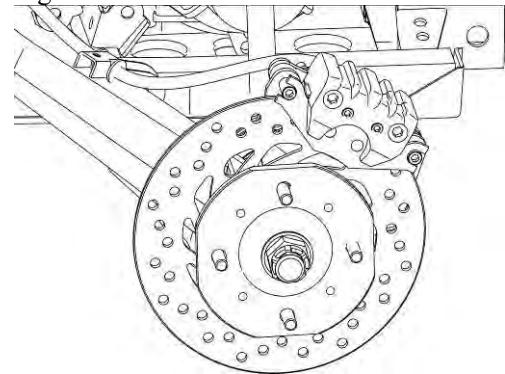

Tightening torque of drive disk lock nut: 280-300 N.m

Figure 5.8.3

Remove one screws and brake oil pipe clip, separating rear brake oil pipe on the left side from upper swing arm.

Figure 5.8.3

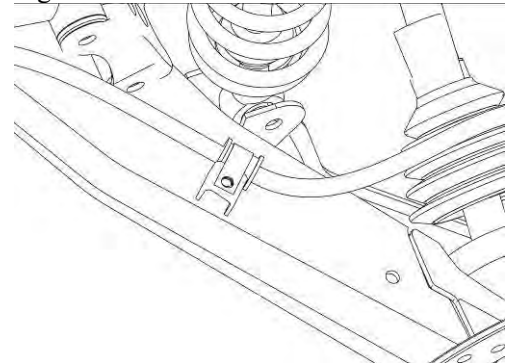

Figure 5.8.4

Remove the two installing bolts of the left brake caliper and remove the caliper from the disc brake.

Tightening torque of main body bolt of rear brake pump: 45-55 N.m

Available overhaul:

Replace and conduct maintenance of rear brake pump main body and rear drive disk combination

Note: during dismantling, brake action is prohibited to be conducted, avoiding brake friction plate close or placing spacer between friction plates to avoid friction plate close and to facilitate future installation.

Figure 5.8.4

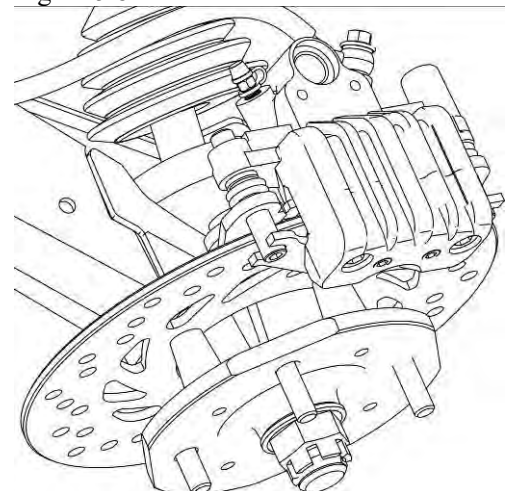

Figure 5.8.5

Remove the installing bolts on the sway bar. There are altogether 8 bolts on the left and right sides. After the disassembly, take out the sway bar for maintenance.

Fastening bolt torque of horizontal stabilizer pull rod: 60-65 N.m

Available overhaul: replace horizontal stabilizer pull rod

Figure 5.8.5

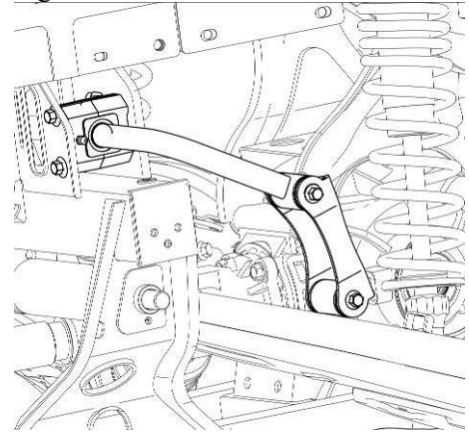

Figure 5.8.6

Remove the 2 installing bolts of the rear A-arm and take out the shock absorber.

Fastening bolt torque of shock absorber: 60-65 N.m

Figure 5.8.6

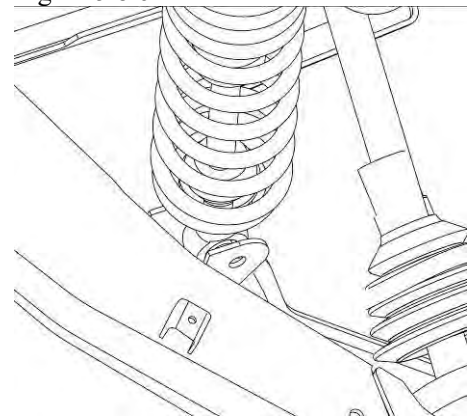

Figure 5.8.7

Pull along axial direction and remove rear semi-axis assembly on the left side.

Available overhaul:

Replace rear semi-axis assembly on the left side

Figure 5.8.7

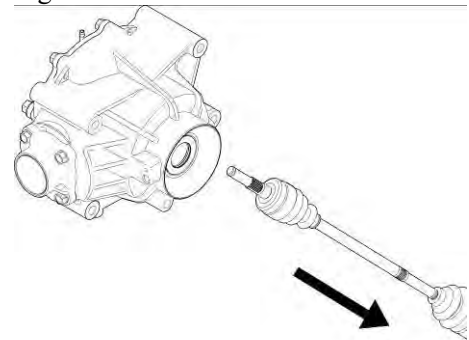
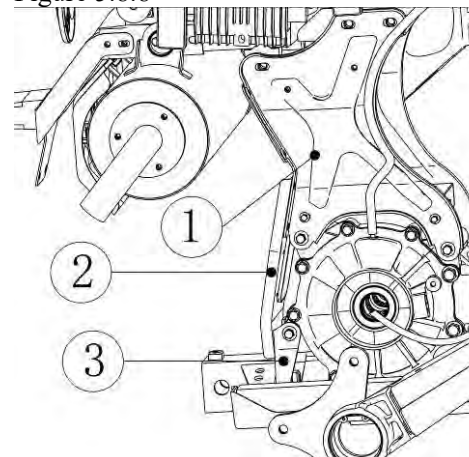

Figure 5.8.8

Remove the rear retarder installing plate numbered ① (only the right side needs to be removed), the rear reducer strengthening plate numbered ② and ③, and finally remove the installing bolt to take out the rear retarder.

Tightening screw torque of rear retarder: 60-65 N.m

Figure 5.8.8



5.9. Direction column and front retarder combination

I. Dismantle direction column combination

Figure 5.9.1

Remove two bolts, separating fixture block combination ① of direction column from vehicle.

Figure 5.9.1

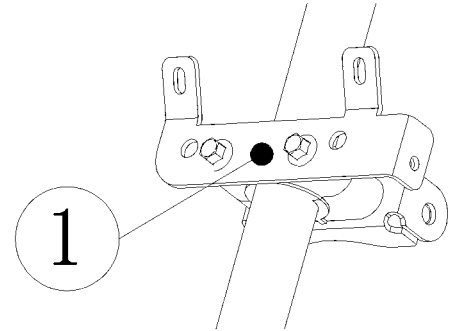

Figure 5.9.2

Remove split pin ② and spline nut ③ (two pieces for each), separating left and right steering pull bar ④ from direction column ⑤.

Remove two screws and lift along axial direction to remove column direction column combination ⑤.

Figure 5.9.2

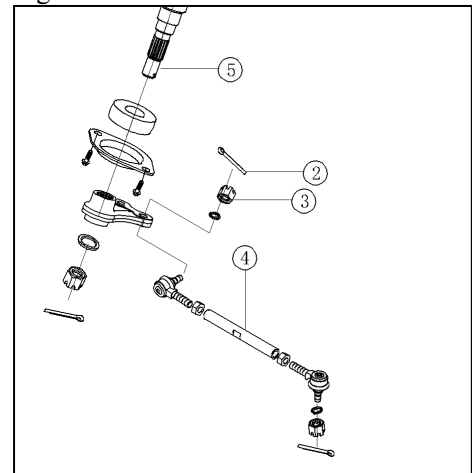
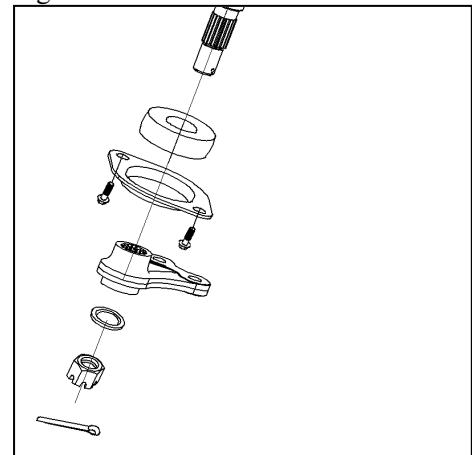

Figure 5.9.3

Remove the cotter pin, remove the nut, take out the rocker arm, loosen the two bolts and remove the bearing set plate.

Figure 5.9.3



II. Dismantle left side of front retarder assembly

Figure 5.9.4

First place intermediate part of a vehicle to a dedicated support, leaving front and rear wheels of the vehicle in suspended status.

Remove four nuts and pull along axial direction to remove front wheel combination ⑥.

Tool: 19mm sleeve

Tightening torque of front wheel nut: 70-80 N.m

Available overhaul:

Replace front wheel combination

Figure 5.9.4

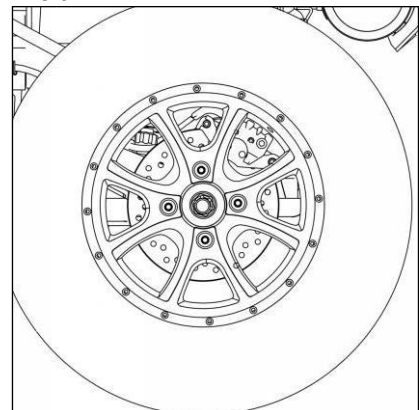

Figure 5.9.5
Remove split pin at the left drive disk.

Figure 5.9.6
Remove two bolts and remove main body combination of front brake pump along arrow direction.

Tightening torque of main body bolt of front brake pump: 24-28 N.m

Available overhaul: replace and conduct maintenance of main body of front brake pump

Figure 5.9.7
Remove the cotter pin, loosen the castle nut and take out the front drive disk combination.
Tightening torque of drive disk lock nut: 280-300 N.m

Available overhaul: replace and conduct maintenance of drive disk combination

Figure 5.9.8
Remove the cotter pin of the upper and lower A-arms, loosen the castle nuts of the upper and lower A-arms at first, and then loosen the castle nuts of the direction pull rod, and finally take the steering knuckle out of the vehicle.
Bolt tightening torque of front lower swing arm: 60-65 N.m
Available overhaul: replace steering pull bar on the left

Figure 5.9.5

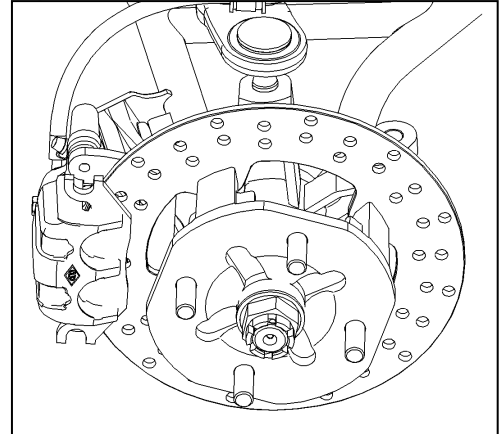

Figure 5.9.6

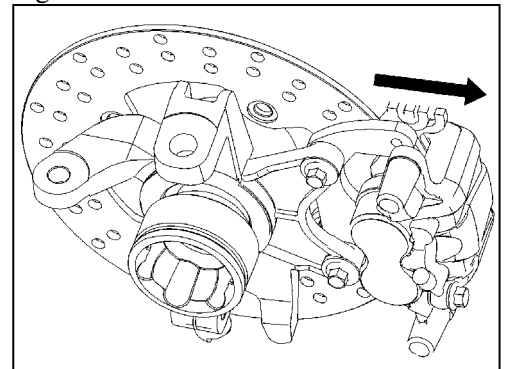

Figure 5.9.7

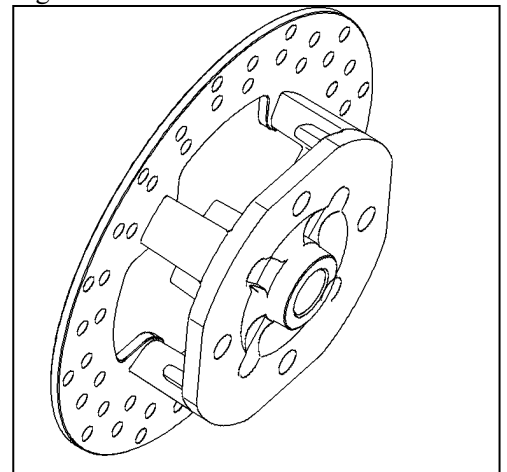

Figure 5.9.8

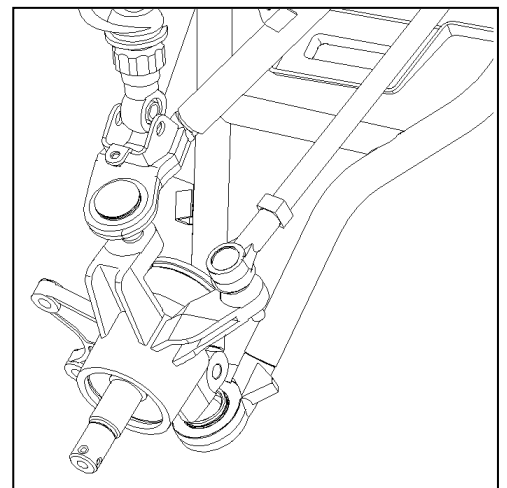

Figure 5.9.9

Remove tightening bolt and nut below left front shock absorber (one piece for each), separating left front shock absorber and front upper swing arm, and separating front upper swing arm and steering knuckle before removing left steering knuckle assembly along axial direction.

Pull along axial direction and remove left front semi-axis.

**Bolt tightening torque of front shock absorber:
60-65 N.m**

Available overhaul:

Replace left front semi-axis

Figure 5.9.9

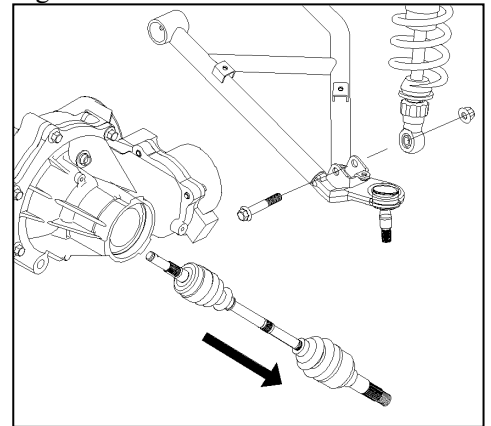

Figure 5.9.10

Figure 5.9.10

Remove the three bolts of the front reducer, remove the hoop of the front drive shaft sleeve after the plug, move a certain distance forward, withdraw the front drive shaft, take out the front reducer from the right side of the body for maintenance.

Note: Removal of the front reducer does not require removal of any bolts of engine.

**Vehicle tightening bolt torque of front retarder:
60-65 N.m**

Available overhaul:

Replace front retarder assembly

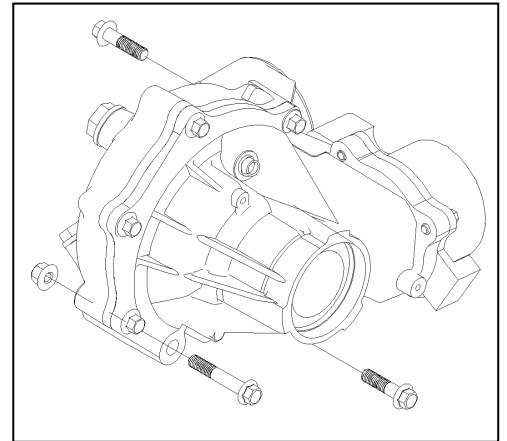

Re-installation

Conduct reinstallation based on reversed sequence of dismantling.

5.10 Attentions and Detection

5.10.1 FUEL SYSTEM

The fuel system of a fuel injection system holds much more a pressure than on carbureted vehicle. Prior to disconnecting a hose or to removing a component from the fuel system, follow the recommendation described here.

Fuel lines remain under pressure at all times. Always proceed with care and use appropriate safety equipment when working on pressurized fuel system. Wear safety glasses. Proceed with care when removing/installing pressure test equipment or disconnecting fuel line connections. Cover the fuel line connection with an absorbent shop rag. Slowly disconnect the fuel hose to minimize spilling. Wipe off any fuel spillage in the engine compartment. Do not allow fuel to spill on hot engine parts and/or electrical connectors. Never use a hose pincher on injection system high pressure hoses. Replace any damage or deteriorated fuel lines.

When the repair is completed, ensure that all hoses are connected and secured.

Always perform the fuel pressure test if any component has been removed. A pressure test must be done before turning the ignition key to ON and setting the engine stop switch to RUN. The fuel pump is activated each time in these conditions.

To locate a leak, pressurize the system. Check for leaking fuel or fuel odor. Spray soapy water on all hose connections and injectors. Air bubbles will show the leaking area.

Inspect the fuel lines, fuel tank, fuel tank cap for damage, clogging and leakage of fuel. If any damages are found, replace the defective parts with the new ones.

FUEL PRESSURE TEST

The pressure test will show the available pressure at the fuel pump outlet. It validates the pressure regulator, the fuel pump and leaks in the system.

Before proceeding to the pressure test ensure the battery is fully charged. Battery voltage must be over 12 volts. Ensure there is enough gas in fuel tank.

Disconnect outlet hose.

Install fuel pressure gauge and T-fitting between disconnected hoses.

Turn ignition key ON and set engine stop switch to RUN and observe fuel pressure. Turn ignition key off then back on. Repeat the test.



Standard fuel pressure: 350kpa.

A rapid pressure drop indicates leakage is from the fuel rail, If there is not leaking then replace fuel pump.

A slow pressure drop indicates leakage either from the fuel injector or from the fuel pressure regulator. Check fuel injector and the fuel pressure regulator for leaks. If it is not leaking then replace fuel pump module.

If no leakage, start engine and observe fuel pressure. The fuel pressure should be the same as above.

If pressure is within limits, fuel pump and the fuel pressure regulator are working adequately.

Remove pressure gauge from inlet hose. Reconnect inlet hose.

FUEL FILTER

Replace fuel filter as per amintenance schedule.

Filter Removal

Remove oetiker clamps and pull hoses off. Detach filter from body.

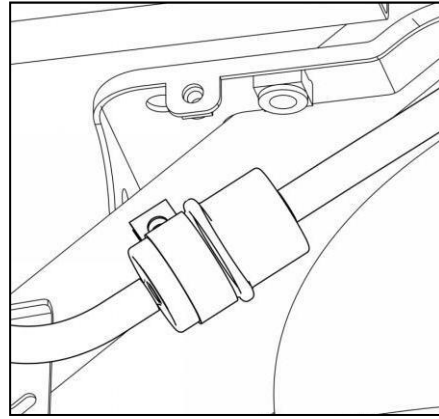

Filter inspection

If fuel filter is suspected to be clogged, it may be checked as follows:

Using low compressed air, check if fuel filter is clogged. Air should flow easily through filter. In doubt, install a new filter.

Filter installation

Use arrow on filter to position it according to fuel flow.

FUEL PUMP

Fuel pump electrical test.

When turning ignition key ON, the fuel pump should run for 5 seconds to build up the fuel pressure in the system.

If the pump does not work, disconnect the connector from the fuel pump.

Install a temporary connector to the fuel pump connector. Apply 12V to this test harness.

CAUTION

Running the fuel pump a few minutes with reverse polarity can damage the pump.

If pump does not run, replace a new pump.

Other wise, check fuse and if good, probe terminals of fuel pump connector on vehicle harness or its connector, Repair or replace appropriate part.

Fuel pump removal

Remove fuel pump outlet hose and harness.

Remove fuel pump retaining screws.

Gently push pump up.

CAUTION

While pulling out the fuel pump, pay attention to fuel sensor float arm. Float arm can get stuck and bend which can reduce the fuel sensor capabilities.

Fuel pump installation

For installation, reverse the removal process but pay attention to the following.

Install a new gasket.

Pay attention to pump orientation.

Tighten retaining screws as per illustrated sequence.

Install hose properly on OUT nipples and harness.

FUEL TANK

Fuel tank draining

Never perform this operation when the engine and/or the exhaust system is/are hot.

Never use a hose pincher on injection system high pressure hoses.

Remove fuel tank cap and siphon gas in an approved fuel container.

Fuel tank removal

Remove

Disconnect vent line from body.

Fuel tank inspection

Inspect fuel tank for any damage or cracks which may result in fuel leaks. If so replace tank with a new one.

Inspect tank and protector attachment points for damage. Inspect protector for damage.

Fuel tank installation

5.10.2 DRIVE TRAIN

FRONT DRIVE	6-1	REAR DRIVE	6-8
FRONT PROPELLER SHAFT	6-8	REAR PROPELLER SHAFT	6-8
FRONT WHEEL HUB	6-8	REAR WHEEL HUB	6-8
FRONT DRIVE SHAFT	6-8	REAR DRIVE SHAFT	6-8
FRONT DIFFERENTIAL	6-8	REAR DIFFERENTIAL	6-8
TIRES AND WHEELS	6-8		

FRONT DRIVE

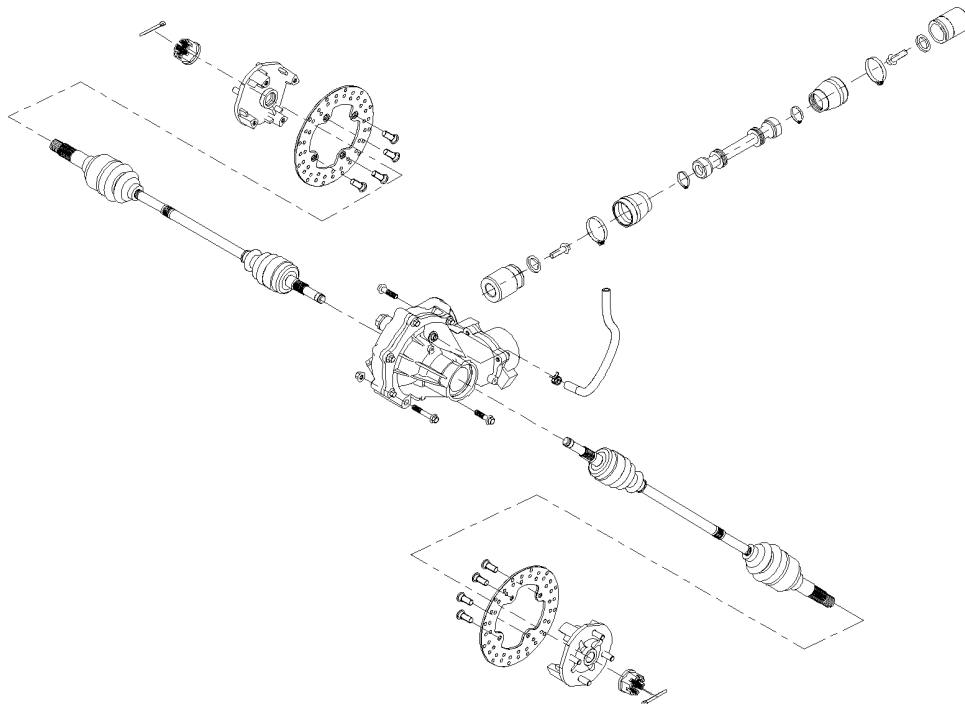

FRONT PROPELLER SHAFT

Inspection

Inspect the propeller shaft for wear or damage. If any defects are found, replace the propeller shaft with new one.

Check if U-joint moves freely in all direction.

Check bellows for holes or brittleness.

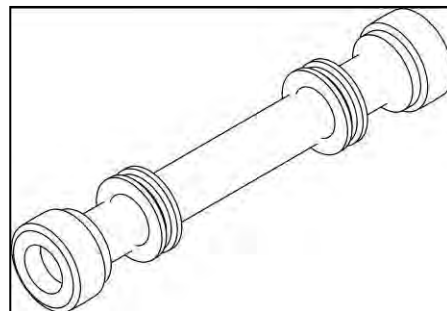

FRONT WHEEL HUB

Inspection

Check wheel hub for cracks or other damages.
 Check inner splines and wheel rim bolts for wear or other damages.
 If any damage is detected on wheel hub, replace it with a new one.

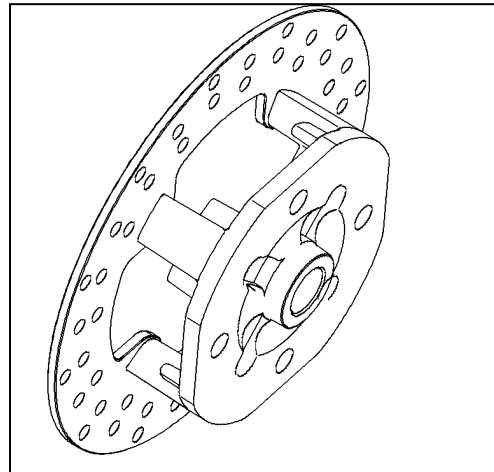

FRONT DRIVE SHAFT

Inspection

Inspect the condition boots. If there is any damage or evidence of leaking lubricant, replace them.
 Check splines for excessive wear. Replace if necessary.
 If the splines on plunging joint are worn, a check of differential inner splines should be done.

Check the ring at the end of drive shaft. If wear is apparent, replace the wear ring.

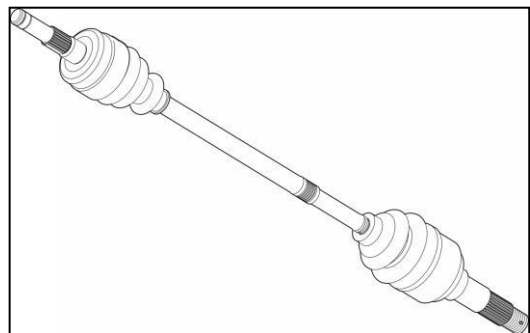

Check if the bearing in knuckle move freely and smoothly. If not, replace them.

Installation

Apply grease to the splines and insert the end of drive shaft in differential and pull joint a little to make sure that the stop ring is locked in differential side gear groove.

Insert the other end of drive shaft in the knuckle and install the knuckle to the lower suspension arm. Install and torque the ball joint retaining bolts to 45N.m

Install all other removed parts.

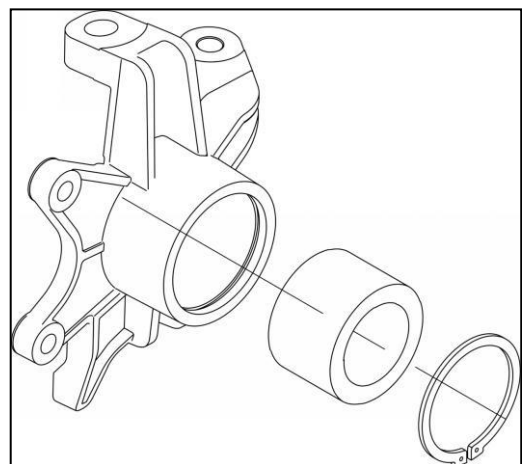

FRONT DIFFERENTIAL

Remove

Clean the drain plug area. Place an oil pan under the front reducer case, and then drain oil completely by removing the drain plug.

Inspection

Inspect the gear case, case cover, bearing, oil seals and dust seal for wear or damage. If any damage or wear is found, replace the oil seal or dust seal with a new one.

Check backlash and drag torque.

Check the breather rubber case for wear or damage. Also, check that the joint of rubber case fits tightly.

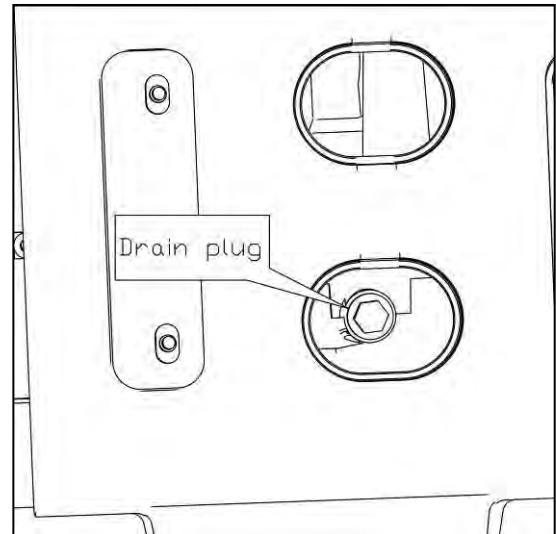

REAR DRIVE

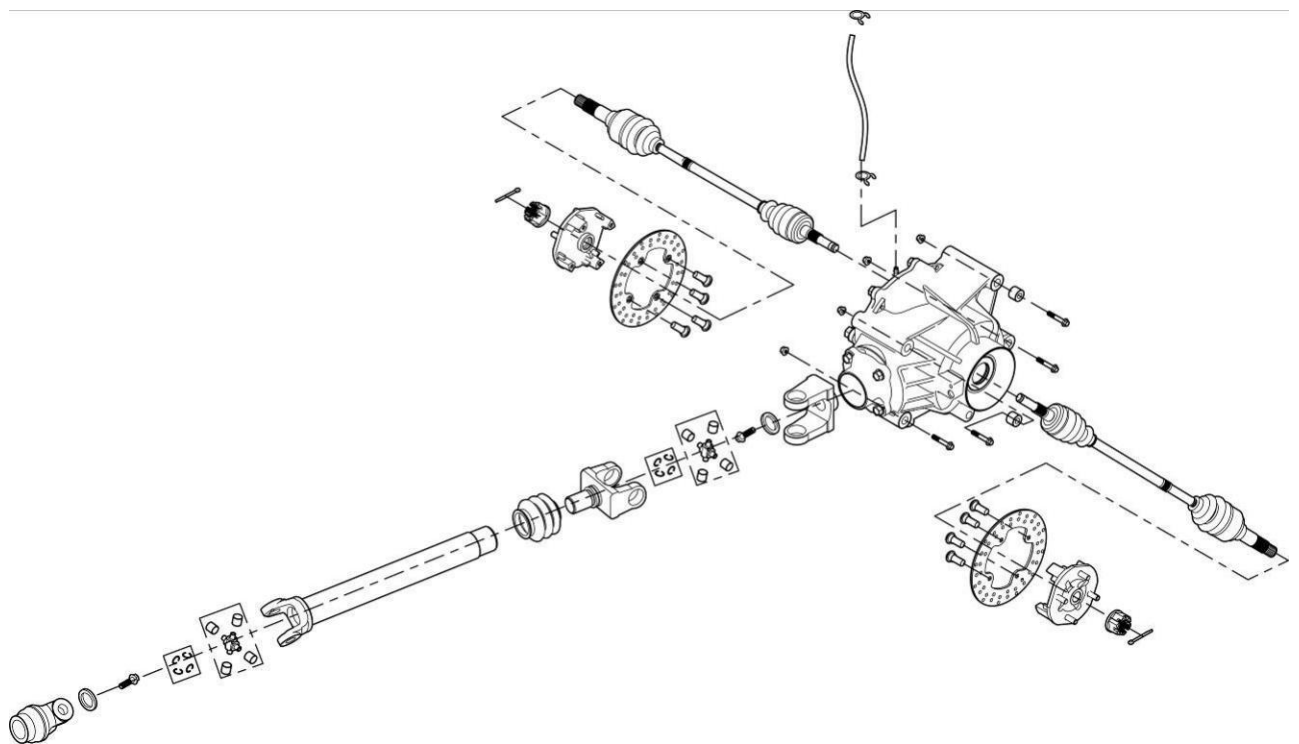

REAR PROPELLER SHAFT

Inspection

Inspect the propeller shaft for wear or damage. If any defects are found, replace the propeller shaft with new one.

Check if U-joint moves freely in all direction.

Check bellows for holes or brittleness.

REAR WHEEL HUB

Inspection

Check wheel hub for cracks or other damages.

Check inner splines and wheel rim bolts for wear or other damages.

If any damage is detected on wheel hub, replace it with a new one.

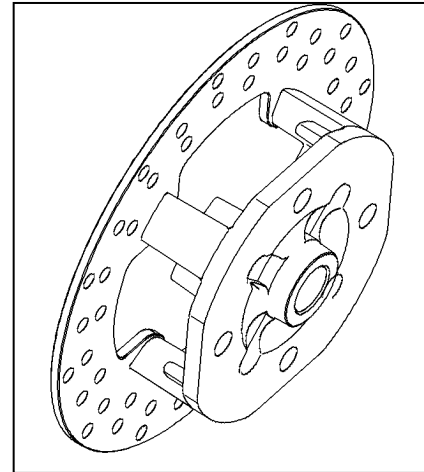

REAR DRIVE SHAFT

Inspection

Inspect the condition boots. If there is any damage or evidence of leaking lubricant, replace them.

Check splines for excessive wear. Replace if necessary.

If the splines on plunging joint are worn, a check of differential inner splines should be done.

Check the ring at teh end of drive shaft. If wear is apparent, replace the wear ring.

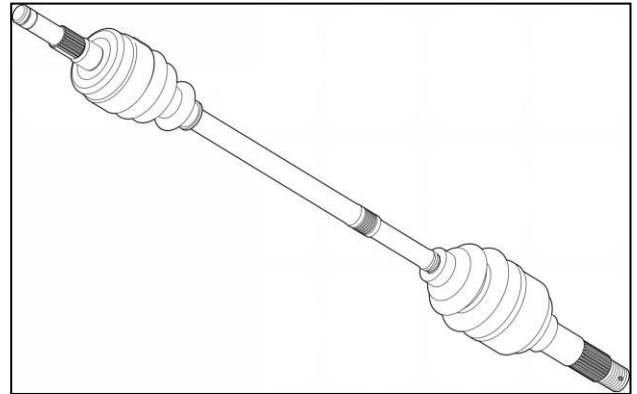

Check if the bearing in kunckle move freely and smoothly. If not, replace them.

Installation

Apply grease to the splines and insert the end of drive shaft in differential and pull joint a little to make sure that the stop ring is locked in differential side gear groove.

Insert the other end of drive shaft in the knuckle and install the knuckle to the upper suspension arm.

Install all other removed parts.

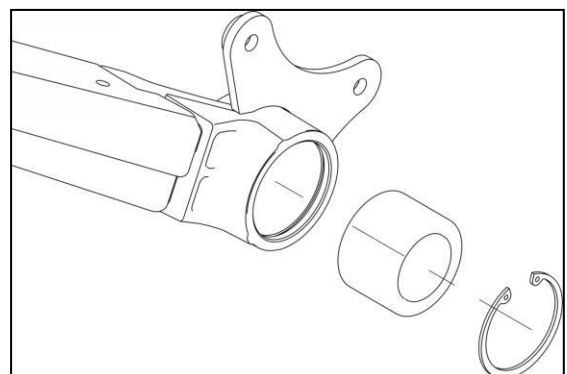

REAR DIFFERENTIAL**Remove**

Clean the drain plug area. Place an oil pan under the front reducer case, and then drain oil completely by removing the drain plug.

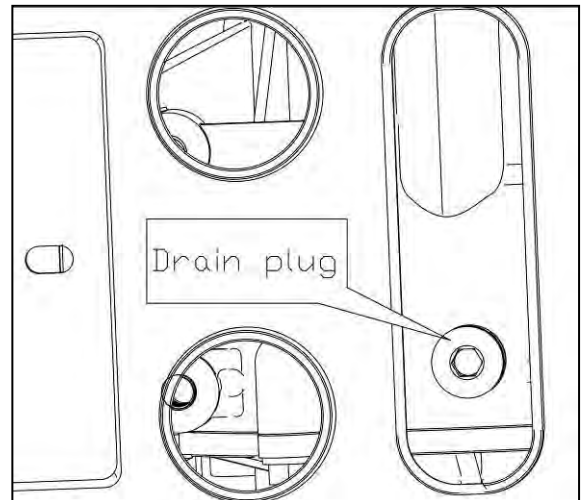
**Inspection**

Inspect the gear case, case cover, bearing, oil seals and dust seal for wear or damage. If any damage or wear is found, replace the oil seal or dust seal with a new one.

Check back lash and drag torque.

Check the breather rubber case for wear or damage.

Also, check that the joint of rubber case fits tightly.

5.10.3 TIRES AND WHEELS

When the tires are replaced, never install a bias tire with a radial tire. such a combination could create handling and/or stability problems.

Dot mix tires of different size and/or de-sign on the same axle.

Front and rear tire pairs must be the identical model and manufacturer.

For unidirectional tread pattern, ensure that the tires are installed in the correct direction of rotation.

The radial tires must be installed as a complete set.

In dismantling tires, use special crowbar and rim protection device.

Tire replacement

Use jack to support vehicle and ensure its no dropping.

Remove the wheels.

After removing the air valve cap, release the tire pressure by depressing the valve.

Dismount the bead from the rim completely.

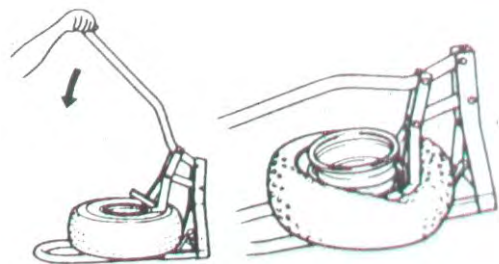

Separate the tire from the rim by using a set of tire levers and rim protectors.

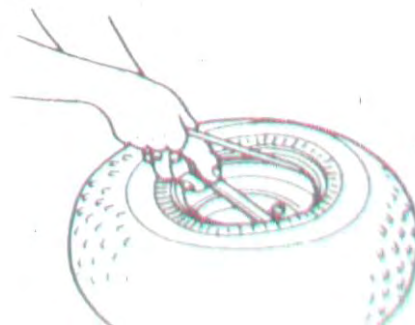

CAUTION

When using the tire lever, do not scratch or hit the sealing portion of the wheel or it may cause air leakage.

Apply tire lubricant to the new tire bead and the flange of the rim. But never apply grease, oil or gasoline to the tire bead because they will deteriorate the tire.

CAUTION

The standard tire fitted on this vehicle is AT26×9-14 for the front and AT26×11-14 for the rear.

The use of tires other than the standard may cause instability. It is highly recommended to use the specified tire.

Inspect the sealing portion of the rim for contamination and distortion before installing the

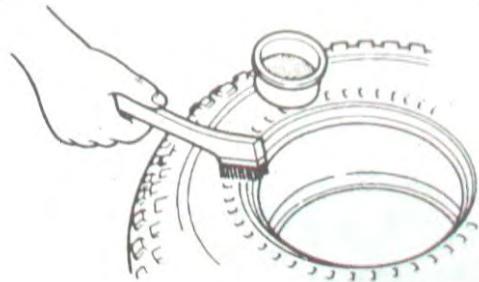

Mount the new tire on the rim.

CAUTION

When installing each tire, make sure the arrow on the tire points in the direction of rotation. Also make sure the outer side of the wheel rim is facing outward.



Inflate the tire to seat the tire bead.

Check the rim line cast on the tire side walls. It must be equidistant from the wheel rim all the way around. If the distance between the rim line and the wheel rim varies this indicates that the bead is not properly seated. If this is so, deflate the tire completely, and unseat the tire bead on both sides. Then coat the bead with clean water and re-seat the tire.

Adjust the tire pressure to specification.

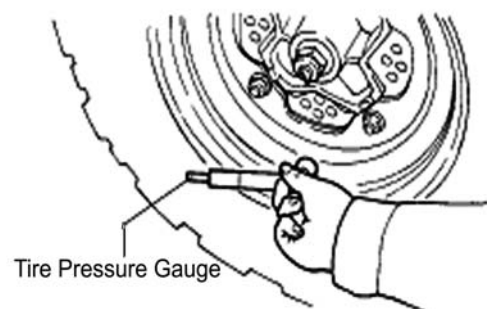

5.10.4 STEERING SYSTEM

Inspect the tie rod for distortion or damage. If any damage are found, replace the tie rod with a new one.

Inspect the tie ends for smooth movement. If there are any abnormalities, replace the tie rod end with a new one.

Inspect the tie rod end boot for wear or damage.

If any damage are found, replace the tie rod end with a new one.

STEERING ALIGNMENT

Park vehicle on flat ground, make sure the tire pressure for right and left tires is same and set to the proper specification, set the front wheels in the straight position, then place a load of 75kg on the seat.

Measure the distance A and B of the front wheels and calculate the difference.

Toe-in.: $B - A = 5\text{mm}$

A: front of front wheel

B: rear of front wheel

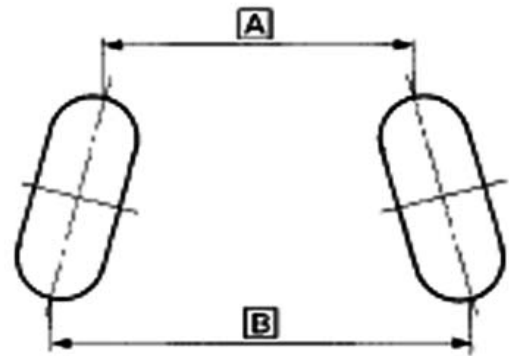

Out of range of toe-in: → Adjust nut of tie rod

CAUTION

After adjusting toe-in, first rotate steering wheel from center position to the left and right completely, to ensure that is the same corner, then slowly run vehicle to see whether its direction can be controlled.

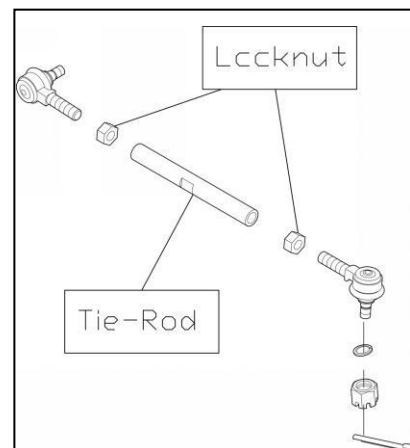

5.10.5 SUSPENSION SYSTEM

FRONT SUSPENSION

The procedure explained below is the same for the RH and LH sides unless otherwise noted. During assembly or installation, use the torque values and service products as in the torque table.

In order to prevent collapse of vehicle, please do not dismantle left and right suspensions simultaneously.
Before overhauling front suspension system, please ensure stable support of vehicle

INSPECTION

Shock absorber

Inspect the shock absorber for oil leakage or damage, inspect the bushing for wear or damage. If any damage are found, replace the front shock absorber with a new one.

Extend and compress the piston several times over its entire stroke. Check that it moves smoothly and with uniform resistance with rod up. Any of the following conditions will denote a defective shock:

- A skip or hang up when reversing stroke at mid-travel.
- Seizing or binding conditions except at extreme end of either stroke.
- A gurgling noise after completing one full compression and extension stroke.

Replace shock if any these conditions are found.

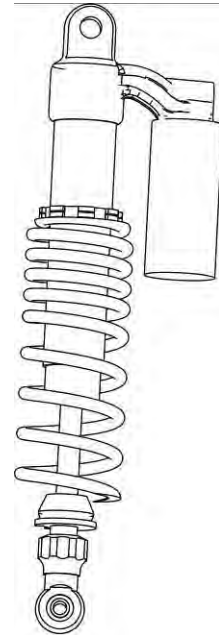

Knuckle

Inspect the knuckle for damage. If any damages are found, replace the knuckle with a new one.

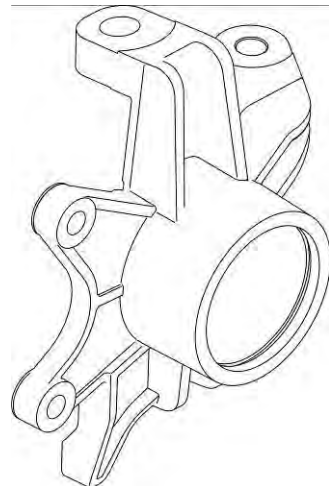

Check bearing and seal for damage or wear, If any damages or wear are found, replace a new one. Rotate the inner race by hand to inspect for abnormal noise and smooth rotation.

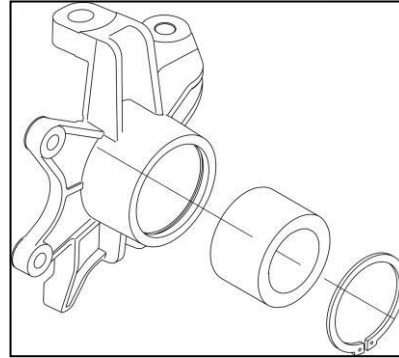

Lower Suspension Arm

Inspect the suspension arm and for damage or distortion. If any damages or distortion are found, replace the suspension arm with a new one.

Move suspension arm from side to side. There should be no noticeable loose. Replace bushing if necessary. Move suspension arm up and down. There should be no noticeable loose. Replace bushing if necessary.

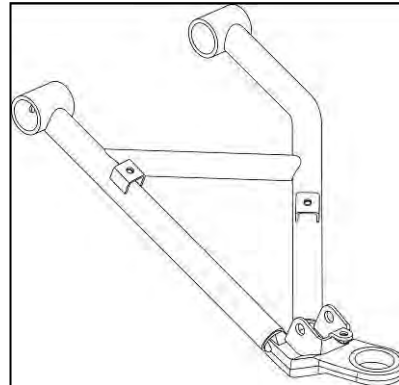

Upper Suspension Arm

Inspect the suspension arm and for damage or distortion. If any damages or distortion are found, replace the suspension arm with a new one.

Move suspension arm from side to side. There should be no noticeable loose. Replace bushing if necessary. Move suspension arm up and down. There should be no noticeable loose. Replace bushing if necessary.

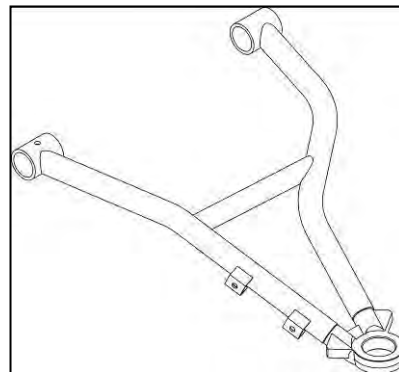

Check ball joint for damage, pitting, looseness and roughness. If so, replace it. Check ball joint bellows for cracks. Change if necessary.

REASSEMBLY

Pay attention to the following points.

1. Install the washers and tighten the knuckle nuts to the specified torque.
2. Replace the removed cotter pins with new cotter pins.

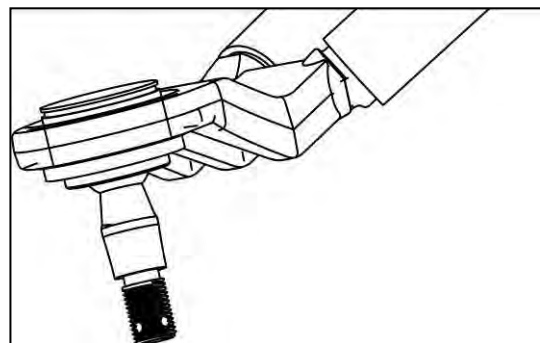

REAR SUSPENSION

The procedure explained below is the same for the RH and LH sides unless otherwise noted. During assembly or installation, use the torque values and service products as in the torque table

INSPECTION

Shock absorber

Inspect the shock absorber for oil leakage or damage, inspect the bushing for wear or damage. If any damage are found, replace the rear shock absorber with a new one.

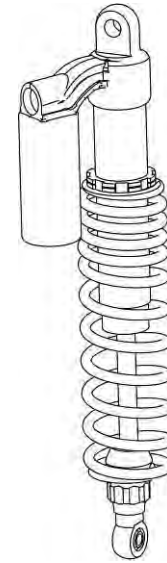

Extend and compress the piston several times over its entire stroke. Check that it moves smoothly and with uniform resistance with rod up. Any of the following conditions will denote a defective shock:

- A skip or hang up when reversing stroke at mid-travel.
- Seizing or binding conditions except at extreme end of either stroke.
- A gurgling noise after completing one full compression and extension stroke.

Replace shock if any these conditions are found

Knuckle

Inspect the knuckle for damage. If any damages are found, replace the knuckle with a new one.

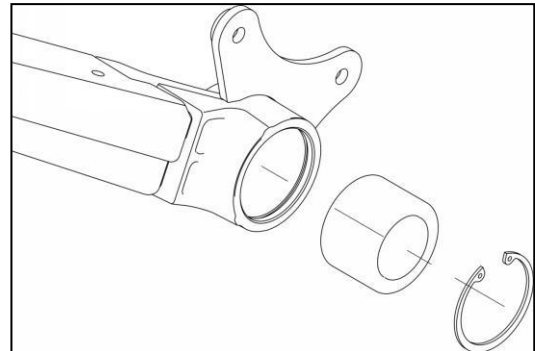

Check bearing and seal for damage or wear, If any damages or wear are found, replace a new one. Rotate the inner race by hand to inspect for abnormal noise and smooth rotation

Suspension Arm

Inspect the suspension arm and for damage or distortion. If any damages or distortion are found, replace the suspension arm with a new one.

Move suspension arm from side to side. There should be no noticeable loose. Replace bushing if necessary. Move suspension arm up and down. There should be no noticeable loose. Replace bushing if necessary.

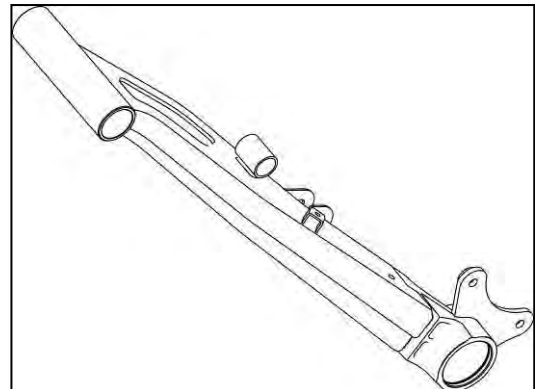

REASSEMBLY

Pay attention to lubricate rear knuckles with lithium-soap based grease.

5.10.6 BRAKES SYSTEM

This brake system is filled with an ethylene glycol-based DOT4 brake fluid. Do not use or mix different types of fluid, such as silicone-based or petroleum-based brake fluids.

Do not use any brake fluid taken from old, used or unsealed containers. Never reuse brake fluid left over from the last servicing or which has been stored for a long periods of time.

When storing brake fluid, seal the container completely and keep it away from children.

When replenishing brake fluid, take care not to get dust into fluid.

When washing brake components, use new brake fluid. Never use cleaning solvent.

A contaminated brake disc or brake pad reduces braking performance. Discard contaminated pads and clean the brake disc with high quality brake cleaner or neutral detergent.

Brake fluid may cause damage to surfaces of plastic and rubber parts. Keep it far away from these parts.

BRAKE FLUID REPLACEMENT

Place the vehicle on a level surface.

Remove the master cylinder reservoir cap and diaphragm.

Suck up the old brake fluid as much as possible.

Fill the reservoir with new brake fluid.

Remove the dust cap of air bleeder valve. Connect a clear hose to the air bleeder valve and insert the other end of the hose into a receptacle.

Loosen the air bleeder valve and pump the brake pedal until the old brake fluid is completely out of the brake system.

Close the air bleeder valve and squeeze and release the brake pedal several times in rapid succession and hold the pedal fully squeezed. Loosen the air bleeder valve for about quarter of a turn so that the brake fluid runs into the receptacle, this will remove the tension of the brake pedal. Then close the bleeder valve, pump and squeeze the pedal and open the valve. Repeat this process until the fluid flowing into the receptacle contains no air bubbles.

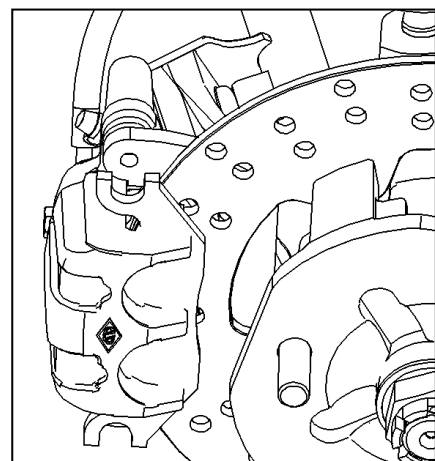
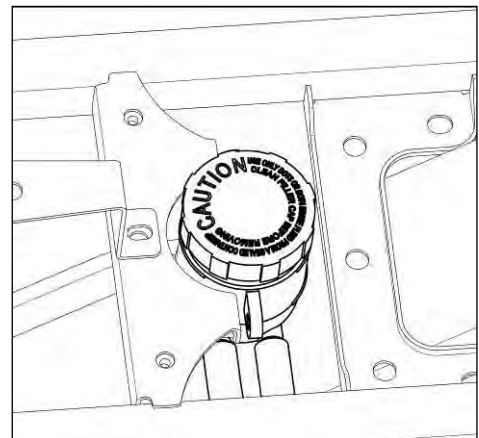
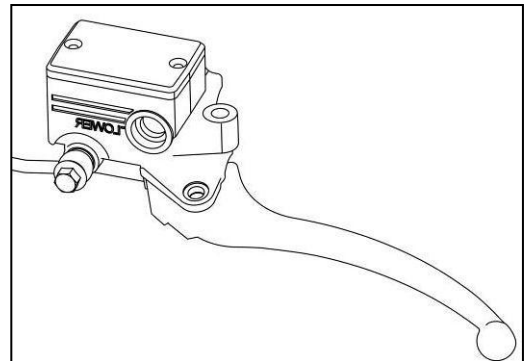

Tighten the air bleeder valve to 6N.m.

Disconnect the clear hose and install the dust cap of air bleeder valve.

Fill the reservoir with new brake fluid to the upper edge of the inspection window.

Install the master cylinder reservoir cap and diaphragm.

CAUTION

While bleeding the brake system, replenish the brake fluid in the reservoir as necessary. Make sure that there is always some fluid visible in the reservoir.

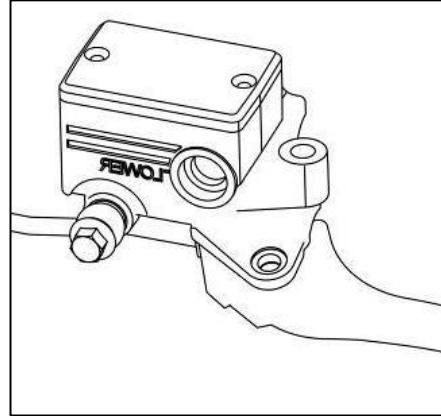

BRAKE PADS REPLACEMENT

Remove the wheel.

Remove the brake caliper mounting bolt and brake pads mounting pins.

Remove the brake pads.

Make sure that pad spring is in position. Install the new brake pads.

Install pad pins by pushing in the pads against pad spring to align pad slots in the pads and caliper body.

Tighten the brake pad mounting pins to 18N.m.

Tighten the brake pad mounting pins to 80N.m.

CAUTION

Do not operate the brake pedal during or after brake pad removal.

Replace the brake pads as a set, otherwise braking performance will be adversely affected.

After replacing the brake pads, pump the brake pedal a few times to check for proper brake operation and then check the brake fluid level.

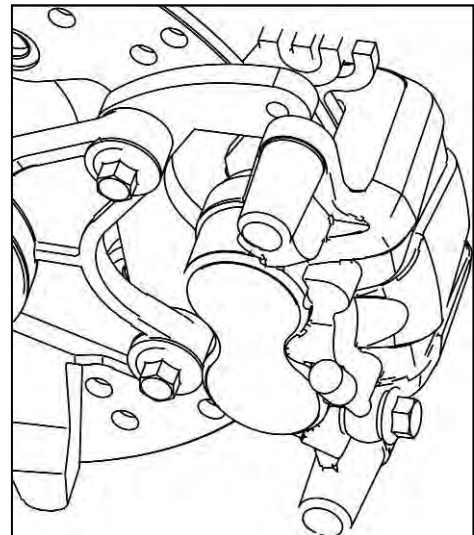

BRAKE DISC

Removal and disassembly

Remove the wheel.

Remove the caliper and hub.

Remove the brake disc.

Inspection

Inspect the brake disc for cracks or damage and measure the thickness using the micrometer. If any damage are found or the thickness is less than the service limit, replace the brake disc with a new one.

Minimum thickness of front brake disc: 3.5mm.

Minimum thickness of rear brake disc: 3.0mm

Measure the warpage using the dial gauge. If the warpage exceeds the service limit, replace the brake disc with a new one.

Maximum warpage of brake disc:0.3mm.

Reassembly and remounting

Reassemble and remount the brake disc in the reverse order of removal and disassembly. Pay attention to the following points:

Install the disc to the wheel hub with the punching letters on the disc showed up.

Make sure that the disc is clean and free of any greasy matter.

Apply THREAD LOCK to the brake disc bolts and tighten them to 26N.m.

BRAKE CALIPER

Removal

Loosen wheel nuts.

Raise vehicle and support it securely.

Remove appropriate wheel.

Remove the caliper bolts then the caliper. If the caliper is not being removed from the vehicle as during brake pad replacement, simply hang the caliper with a piece of wire to take the weight off the brake hose.

If the caliper is being removed for replacement, drain brake system before removing the banjo fitting and its sealing ring. Remove the caliper from the vehicle.

Catch spilled fluid with a rag. Attach the brake hose in a position to prevent the fluid from flowing out.

Disassembly

Remove brake pads.

Remove slide caliper support and pad spring.

Place rag over piston.

Place caliper body with piston down and apply small squirts of air pressure to the fluid inlet to remove piston.

Remove piston seal.

Clean piston grooves, caliper cylinder and piston with clean brake fluid.

Clean slide pins with brake cleaner and a rag.

Inspection

If boots are deteriorated or hard, replace with new ones.

Check caliper cylinder for scratches, rust or other damages. If so, replace caliper.

Check piston for scratches, rust or other damages. If so, replace caliper.

Assembly

Coat piston seal with clean brake fluid and install it into piston grooves in caliper.
 Coat piston with clean brake fluid and install into cylinder with the closing toward caliper body.
 Apply dielectric grease into sliding bores and install slide pins.
 Install pad spring, caliper bracket and pads.

Installation

For installation, reverse the removal procedure, pay attention to the following details:
 Use new sealing washers when installing banjo fitting retaining brake hose to caliper.
 Install caliper in its original position.
 Bleed the brake system
 Check for leaks and make sure the brakes operate normally before driving.

BRAKE LIGHT SWITCH

The brake light switch is located on the brake master cylinder. It can not be adjusted.

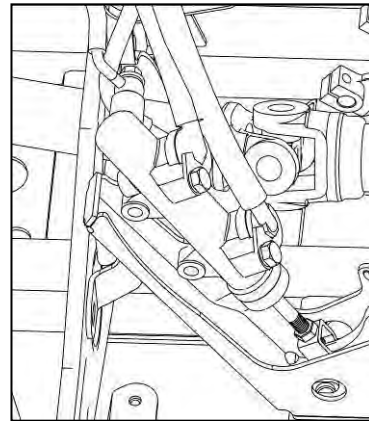

Inspection

First ensure brake light is good.
 Check switch for dirt or corrosion. Make sure it is operating properly.
 Depress brake pedal and check for brake light to turn on. Repeat with the brake pedal.

Test

Disconnect switch connectors.
 Check switch operation as follows.

SWITCH POSITION	PIN		RESISTANCE
Firmly pushed	1	2	0.2Ωmax
Released			Infinite

If switch is defective, replace with a new one. If switch tests good, check wiring harness.

Remove

Disconnect switch connectors.
 Drain brake system.
 Unscrew brake light switch from master cylinder.
 Catch spilled fluid with a rag.

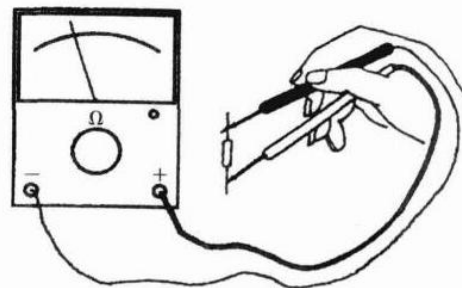

Installation

For installation, reverse the removal procedure.
 Bleed the brake system
 Check for leaks and make sure the brakes operate normally before driving.

BRAKE HOSE

Inspection

Brake hose should be inspected frequently for leaks and damages.

Check if the hoses are crushed or damaged. Any deformation can restrict the proper flow of fluid and cause braking problems.

Check hoses for cracking scrapes. This damage can cause hose failure under pressure.

When hoses are removed or disconnected, cleanliness must be observed. Clean all joints and connections before disassembly. New hoses should be cleaned with brake fluid before installation to remove any contamination.

Replace any defective parts.

Removal

Before removing any hoses, drain brake system.

Remove all necessary parts to reach the hoses.

Thoroughly clean the area around the joints that will be disconnected.

Place a pan under the joint that will be disconnected.

Disconnect any retaining clips or brackets holding the hose and remove the defective parts.

Installation

Install the new hose.

Make sure the piece will not rub against any other part.

When there is a banjo fitting securing the hose to the caliper or to the master cylinder, always replace the sealing washers with new ones.

Install any retaining clips or brackets.

Refill and bleed the brake system.

Check for leaks and make sure the brakes operate normally before driving.

6. ELECTRICAL SYSTEM

Overhauling information

Warning

- < Bulb will be very hot after turning on headlamp. Please do not touch it immediately after its off. In operation, bulb needs to be cooled.
- < In warning inspection of water temperature, fire or high temperature liquid may be needed. Keep it far away from inflammables and do not to be burnt.
- < The temperature will be very high in turning of headlamp. For replacement, grease dirt will be splashed to glass in case of operation with bare hands or wearing dirty gloves. As a result, hot spots and glass deformation may be caused with damage to bulb as well.
- < Pay attention to the following in replacing bulb:
 - Do not replace bulb when it is on. Turn off ignition switch and replace it after cooling bulb.
 - In order to avoid splashing grease to glass, wear clean gloves in replacing bulb.
 - Use cloth with alcohol or banana water to clean glass to prevent any grease sticking to glass.
- < Check battery to confirm whether it is normal.
- < Regularly check switch and do not dismantle it from vehicle in inspection.
- < Cables and wires of each part need to be arranged reasonably. (→Chapter 1) For dismantling and installation of tail lamp and rear steering lamp, please refer to chapter 2.

**Electrical
Charging system**

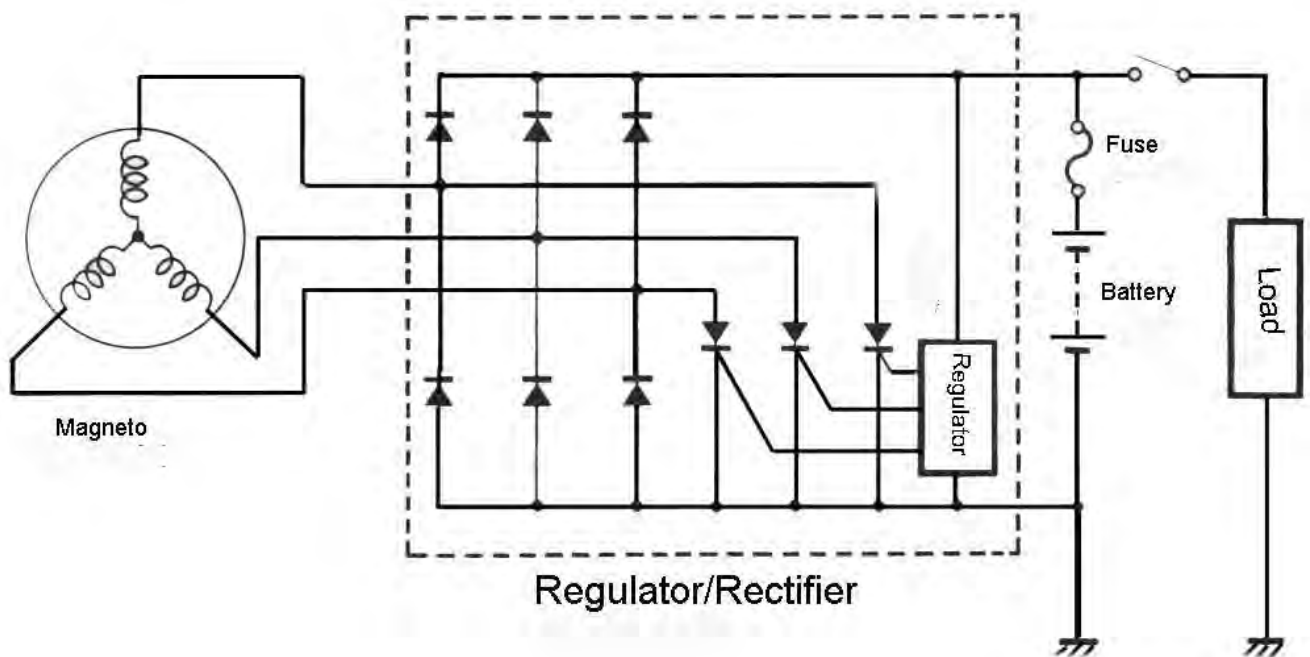

**GENERAL
SYSTEM DESCRIPTION**

The purpose of the charging system is to keep the battery at a full state of charge and to provide the electrical system with the required electrical power for normal vehicle operation.

Magneto

The magneto is the primary source of electrical energy. It transforms magnetic field into electric current (AC).

The magneto has a 3 phase series stator.

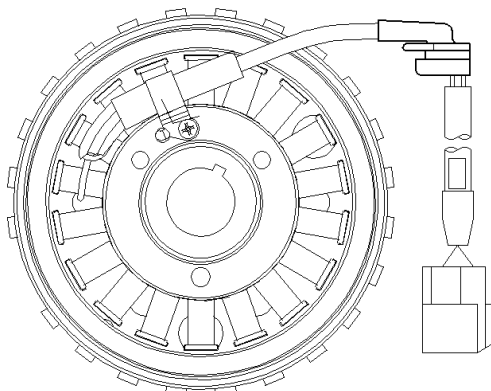

Voltage Regulator/Rectifier

The rectifier receives AC current from the magneto and transforms it into direct current (DC).

The voltage regulator, included in the same unit, limits voltage to prevent any damage to electrical components.

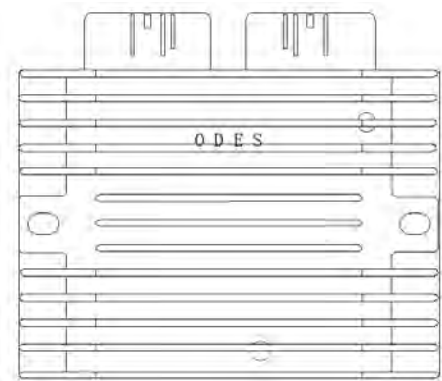

Battery

The battery supplies DC power to the electric starter for cranking the engine. During engine starting, it also supplies DC power to the entire electrical system.

At low engine RPM operation and high current load conditions, it supplements the magneto output and helps to maintain a steady system voltage.

**INSPECTION
CHARGING SYSTEM OUTPUT**

First ensure that battery is in good condition prior to performing the following tests.

Testing the Output Voltage Using multimeter.

1. Start engine with the less consumption as possible (no lights, no accessories).
2. Increase engine RPM as specified in the following table and read voltage in the multimeter.

OUTPUT VOLTAGE TEST

ENGINE SPEED	VOLTAGE (DC)
4000 RPM	14.5 ± 0.5V

If voltage is above specification, replace voltage regulator/rectifier.

If voltage is below specification, check stator output and wiring harness prior to concluding that voltage regulator/rectifier is defective.

Check stator

Stator Connector Access

The stator is directly connected to the voltage regulator/rectifier.

Testing the Stator Continuity

1. Disconnect the stator connector from the voltage regulator/rectifier.
2. Check resistance between YELLOW wires.

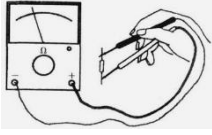
REQUIRED TOOL		TERMINAL	RESISTANCE @ 20°C (68°F)
UNIT 115 MULTIMETER		1 and 2	0.15 - 0.30 Ω
		1 and 3	
		2 and 3	

3. If any reading is out of specification, replace stator.
4. Re-plug connectors properly.

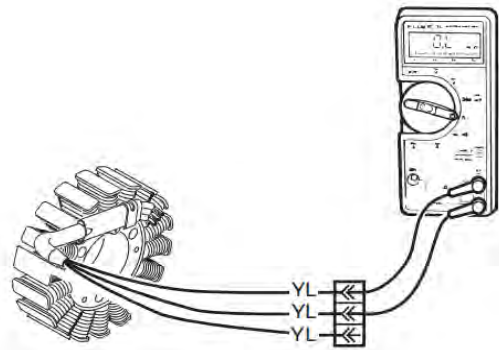

Testing the Stator Static Insulation

1. Disconnect the stator connector from the voltage regulator/rectifier.
2. Connect multimeter between any YELLOW wire (on stator connector) and engine ground.

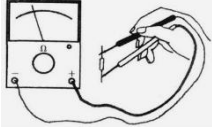
REQUIRED TOOL		TEST PROBES	RESISTANCE @ 20°C (68°F)
UNIT 115 MULTIMETER		Any YELLOW wire and engine ground	Infinite (open circuit)

3. If there is a resistance or continuity, the stator coils and/or the wiring is shorted to ground and needs to be repaired or replaced.
4. Re-plug connectors properly.

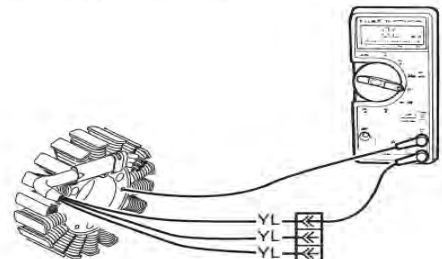

Check battery

1. Connect a battery load tester.
2. Ensure proper test conditions.

If battery voltage drops below specification during test, replace battery and perform a CHARGING SYSTEM LOAD TEST.

TEST CONDITIONS	
Initial battery voltage‡	Above 12.5 Vdc
Engine	OFF
Load	3 times the amp-hour (AH) rating
Time	15 seconds
‡ Required for accurate testing	
SPECIFICATION	
Battery	Above 9.6 Vdc

CHARGING SYSTEM LOAD TEST

1. Connect a battery load tester.
2. Start vehicle and read voltage on tester.

SPECIFICATION	
Voltage	12.5 - 15 Vdc

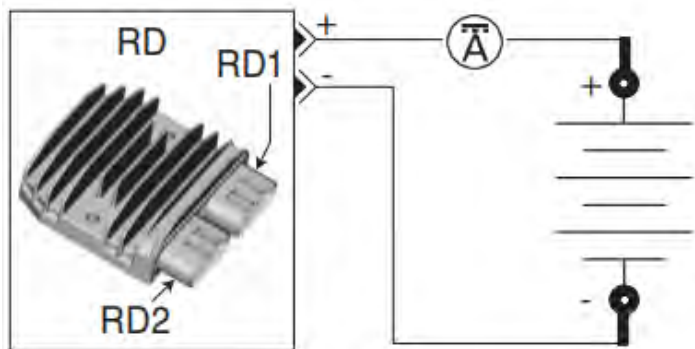

If voltage is above specification, replace regulator and continue CHARGING SYSTEM LOAD TEST.

3. Connect an ammeter around RD1-1 wire.



DC CURRENT TEST WITH INDUCTIVE AMMETER

1. Output connector of voltage regulator
2. Ammeter clamped over RED wire

4. Ensure proper test conditions.

5. Read amperage on ammeter.
45 ± 5Amps

TEST CONDITIONS	
Battery voltage at idle‡	Above 12.6 Vdc
Engine	Increase to 4000 RPM
Load	As required to decrease battery voltage to 12 Vdc
Time	15 seconds
‡ Required for accurate testing	

NOTE: With a fully charged battery and no electrical loads, specification is less than 10A.

If amperage or voltage is not within specification, verify magneto and wires. Replace:

- Voltage regulator if magneto test is within specifications.
- Magneto if magneto test is not within specifications.

VOLTAGE REGULATOR (RD)

Testing the Voltage Regulator Continuity

Due to internal circuitry, there is no static test available

Voltage Regulator Wire Identification

FUNCTION	PIN	COLOR
12Vdc output	RD1-1	RD
12Vdc ground	RD1-3	BK
12Vac input	RD2-1	BK
12Vac input	RD2-2	BK
12Vac input	RD2-3	BK

Testing the Voltage Regulator Power

1. Check voltage at RD1-1.

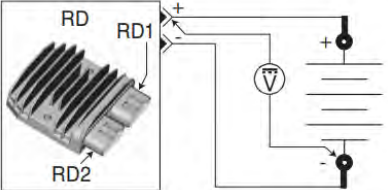

TEST CONDITIONS	
RD1-1	Hot at all times

BACKPROBE	PROBE	SPECIFICATION
RD1-1	BAT2 (-)	Battery voltage

2. Connect a battery load tester.

3. Start vehicle.

4. Ensure proper test conditions.

TEST CONDITIONS	
Battery voltage at idle†	Above 12.6 Vdc
Engine	Increase to 4000 RPM
Load	As required to decrease battery voltage to 12 Vdc
Time	15 seconds

† Required for accurate testing

5. Measure voltage drop.

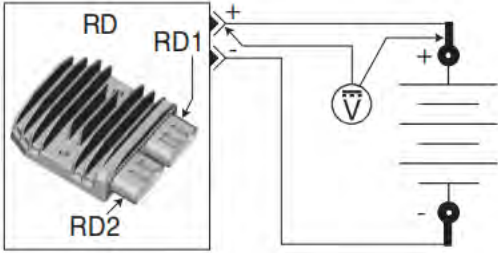

BACKPROBE	PROBE	SPECIFICATION
RD1-1	BAT1 (+)	Under 0.2 Vdc

If voltage drop is above specification, locate and repair damaged connector/wire.

Testing the Voltage Regulator Ground

1. Check ground at RD1-3.

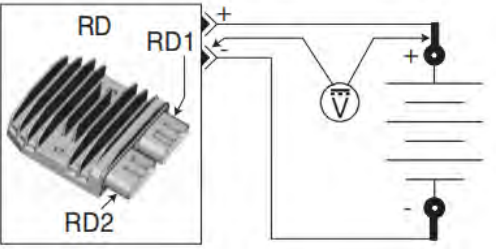

TEST CONDITIONS	
RD1-3	Permanent ground

BACKPROBE	PROBE	SPECIFICATION
RD1-3	BAT1 (+)	Battery voltage

3. Start vehicle.

4. Ensure proper test conditions.

TEST CONDITIONS	
Battery voltage at idle‡	Above 12.6 Vdc
Engine	Increase to 4000 RPM
Load	As required to decrease battery voltage to 12 Vdc
Time	15 seconds
‡ Required for accurate testing	

5.Measure voltage drop.

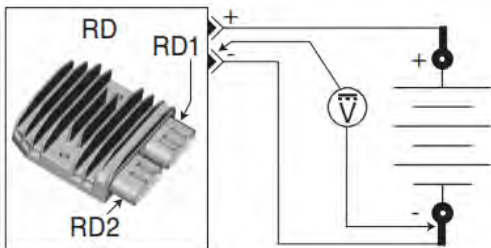

BACKPROBE	PROBE	SPECIFICATION
RD1-3	BAT2 (-)	Under 0.4 Vdc

If voltage drop is above specification, locate and repair damaged connector/wire.

BATTERY

Refer to battery manufacturer's instructions for proper filling, activation and routine charging procedures.

Battery Access

The battery is located underneath the driver's seat.

Removing the Battery

1. Remove under seat storage compartment if equipped.
2. Remove battery cover
3. Disconnect BLACK (-) cable first, then the RED (+) cable.

NOTICE Always respect this order for removal; disconnect BLACK (-) cable first.

- 4.Remove battery.

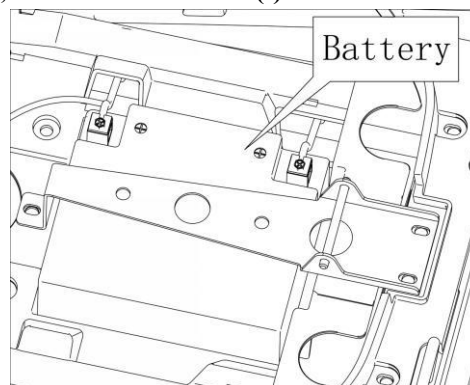

Cleaning the Battery

Clean the battery rack, cables and battery posts using a solution of baking soda and water.

Remove corrosion (if so) from battery cable terminals and battery posts using a firm wire brush. Rinse with clear water and dry well.

Inspecting the Battery

Visually inspect battery casing for cracks or any other damages. If casing is damaged, replace battery and thoroughly clean battery support with a water and baking soda solution.

Inspect condition of battery posts, battery support, holding strap and strap attachment points and wire terminal lugs.

Battery Storage

It is not necessary to remove the battery during vehicle storage but it is recommended for long term storage.

If the battery is left in the vehicle during storage or used infrequently, disconnect the BLACK (-) negative battery cable to eliminate battery current drain from the electrical equipment.

Recharge the battery once a month with an approved battery charger as per manufacturer's recommendations.

Clean battery, battery support and connections as required.

For other recommendations during storage, refer to battery manufacturers instructions.

⚠ WARNING
 Ensure battery is stored in a safe place, out of reach for children.

Activating a New Battery

Refer to the instructions provided with the battery.

Charging a Battery

⚠ WARNING
 Always wear safety glasses and charge in a well ventilated area. Never charge or boost a battery while it is installed on vehicle. Do not open the sealed cap during charging. Do not place battery near open flame.

NOTICE If battery becomes hot, stop charging and allow it to cool before continuing.

NOTE: If battery pressure increases due to overcharging, the valve opens to release excess pressure, preventing battery damage.

An automatic charger is a fast and convenient way for error-proof charging.

Always follow the battery manufacturer's charging instructions.

When using a constant current charger, charge battery according to the chart below.

Battery Voltage Below 12.8 V and Above 11.5V

STANDARD CHARGING (RECOMMENDED)	
APPROXIMATE TIME	CHARGE
4 - 9 HOURS	2 A

QUICK CHARGING	
APPROXIMATE TIME	CHARGE
50 MINUTES	10 A

Installing the Battery

NOTICE Always connect RED (+) cable first then BLACK (-) cable.

STARTING SYSTEM

GENERAL

SYSTEM DESCRIPTION

The starting system is composed of an electric starter supplied in current by the battery through a solenoid.

The starter solenoid receives a 12 volt input from the ignition switch and the ground signal is provided by the Gear controller.

- Transmission in Park or Neutral position and/or brake pedal held.
- Ignition switch turns to the start position and hold until the engine starts.

PROCEDURES

STARTER SOLENOID

Starter Solenoid Access

The starter solenoid is located beside the fuse box and the battery , underneath driver's seat.

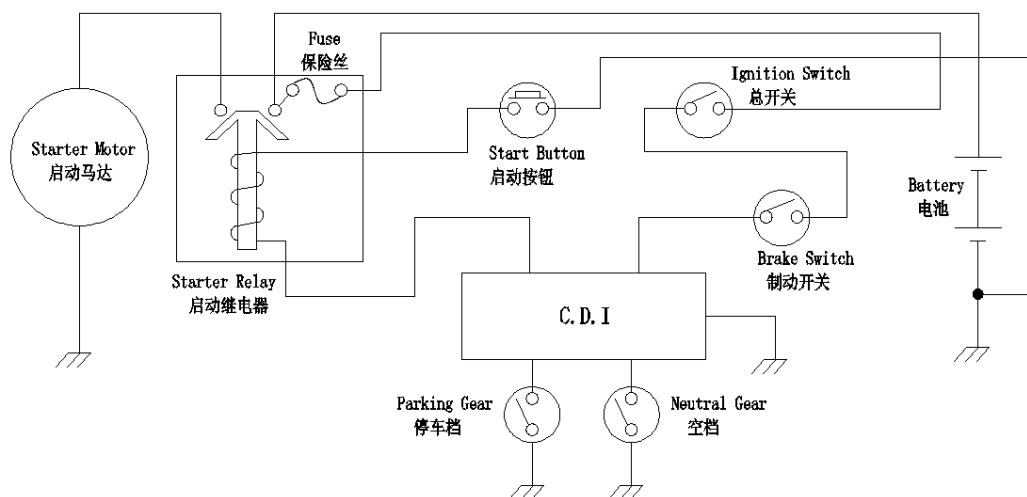

Starter motor

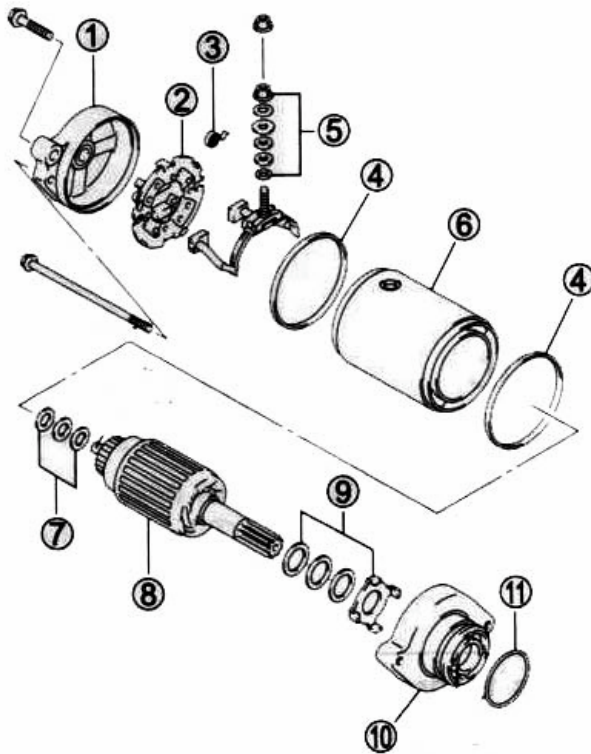

- 1 Bracket
- 2 Brush holder
- 3 Brush spring
- 4 O-Ring
- 5 Washer
- 6 Motor housing
- 7 Washer
- 8 Armature coil
- 9 Washer supporting tools
- 10 Inner bracket
- ① Bracket Ring
- ② Brush Seat
- ③ Brush Spring
- ④ O-ring
- ⑤ Shims
- ⑥ Motor Housing
- ⑦ Washers
- ⑧ Armature Coil
- ⑨ Washer Kit
- ⑩ Inner Bracket
- ⑪ O-ring

Brush

Z Check the brush on the brush holder whether it is worn abnormal, cracked or not smooth.

Worn, cracked, or not smooth: → Replace



Rectifier

Z Check the rectifier whether it is discolored, abnormal wear or concave.

Abnormal wear or damage: → Replace

Z If the rectifier is discolored, grind it with sanding paper, then wipe it with a clean fabric.

Z If there is concave, scrape off insulator B, so that the distance with A is d.

$$d \geq 1.5\text{mm}$$

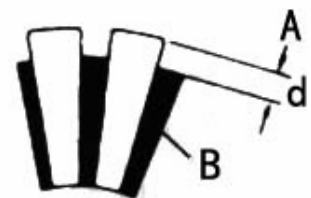

Armature coil

- Z Test the connection between each wire and the armature coil with the multimeter.
- Z If they are not connected, replace the armature shaft.

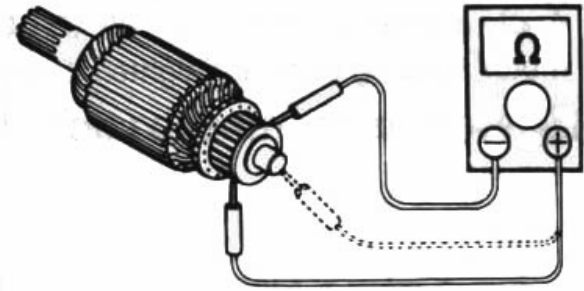

Oil seal

- Z Check the oil seal lip for damage or leak.

Damage or leakage: →Replace the starter motor.

Starter relay

- Z Inter-terminal voltage is 12V. Test the direct connection of positive and negative poles with the multimeter.
- Z If the starter relay clicks and connected, the starter relay is OK.
- Z When there is no voltage of 12V, they are not connected, the starter relay is OK.

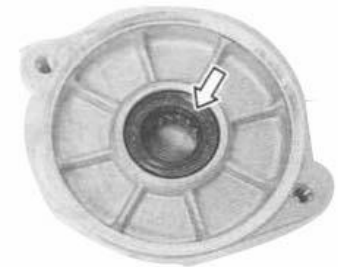

Note: Do not apply battery voltage on the starter relay for more than 2 seconds. This will result in overheating or damaging the relay coil.

- Z Measure the coil resistance with the multimeter. If the resistance exceeds the specified value, replace the starter relay.

The multimeter is set to $1 \times 10 \Omega$.

Starter relay coil resistance: 3-5Ω

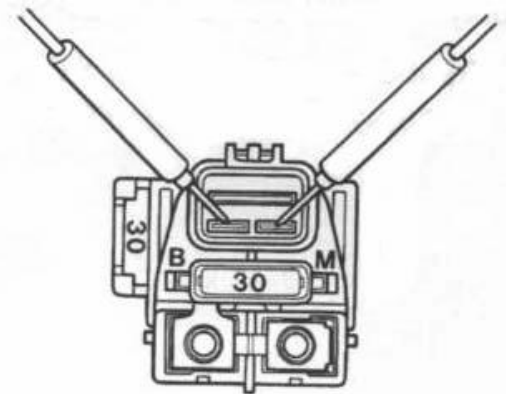

EFI system

schematic diagram of EFI system

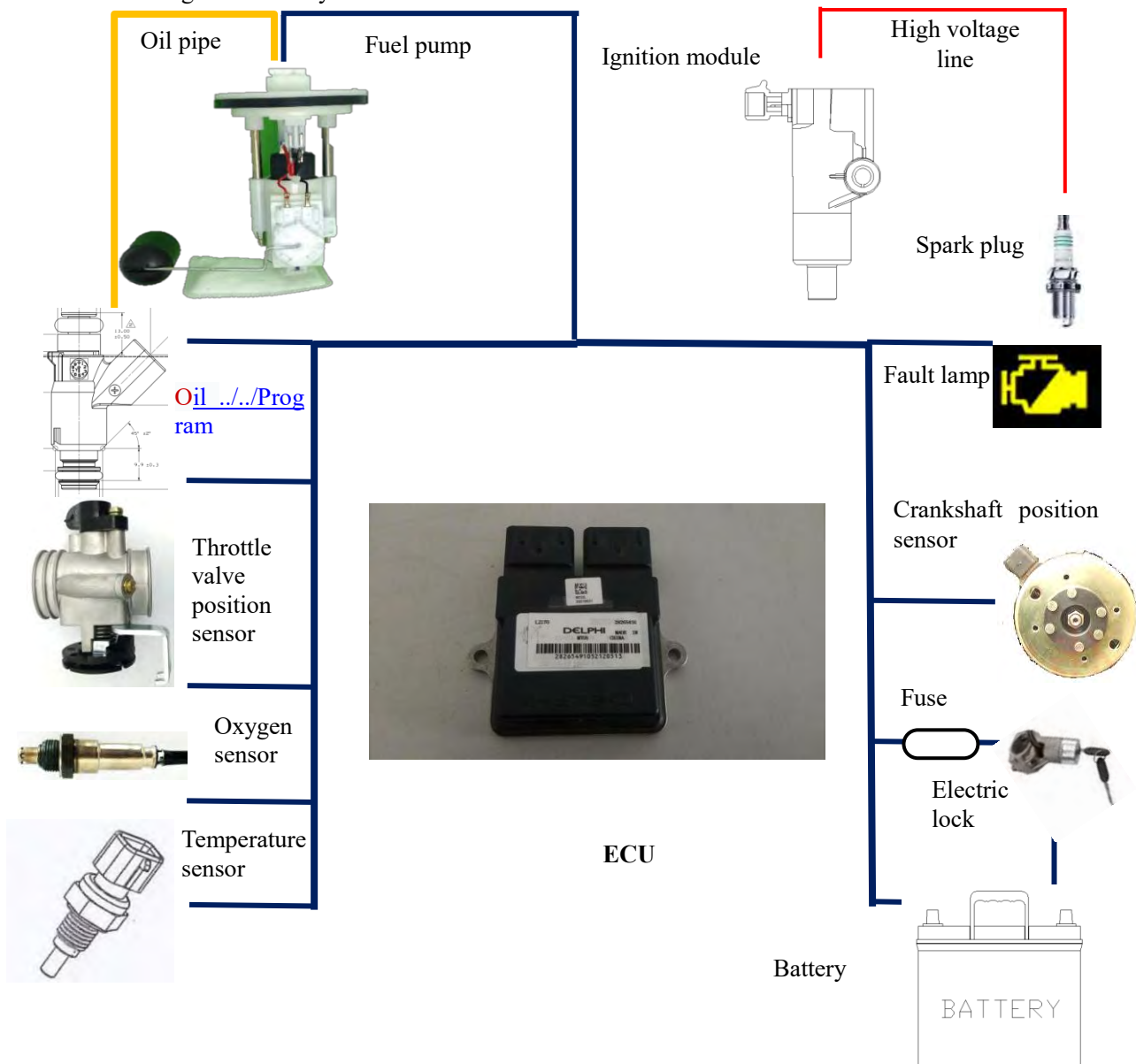

The function of EFI system includes two parts: fuel injection management and ignition management, which are realized by the following institutions.

- (1). **ECU:** it is responsible for the receiving of sensor signal, the formulation of control strategy, and the issue of control signal.
- (2). **Oil supply device:** it is composed of oil pump, tubing and injector. The pump pressurizes the fuel to 250 KPA. The injector is installed on the engine inlet to control the injection timing and fuel injection amount.
- (3). **Ignition device:** it is composed of ignition module, high voltage wire and spark plug. The ignition module has a DC capacitor igniter and a high voltage ignition coil, which can raise the voltage of the battery from 12V to more than 15000V, which also can be transported to the spark plug by high-voltage wire to generate spark discharge.
- (4). **Sensors:** including: a. The oxygen sensor, which mounted on an exhaust pipe to detect oxygen concentration in exhaust gases, can realize the closed-loop regulation of the mixture concentration, and when the closed-loop adjustment, the output of 0 ~ 0.9V alternating signal can be achieved; b. cylinder temperature sensor, which is installed on the engine cylinder head to detect the engine body temperature, will affect the starting thickening amount; c. Crankshaft position sensor, which is integrated on magneto to provide crankshaft angle signal, is the time reference for fuel injection and ignition control; d. The throttle position sensor is mounted on the throttle body to measure the rotation angle of the throttle valve.
- (5). **Other:** including: a. throttle body, which controls air intake through throttle pull wire; b. Fault alarm lamp, which is installed on the dashboard for fault alarm; c. Battery, door lock, fuse for power supply to EFI system.

Ignition system

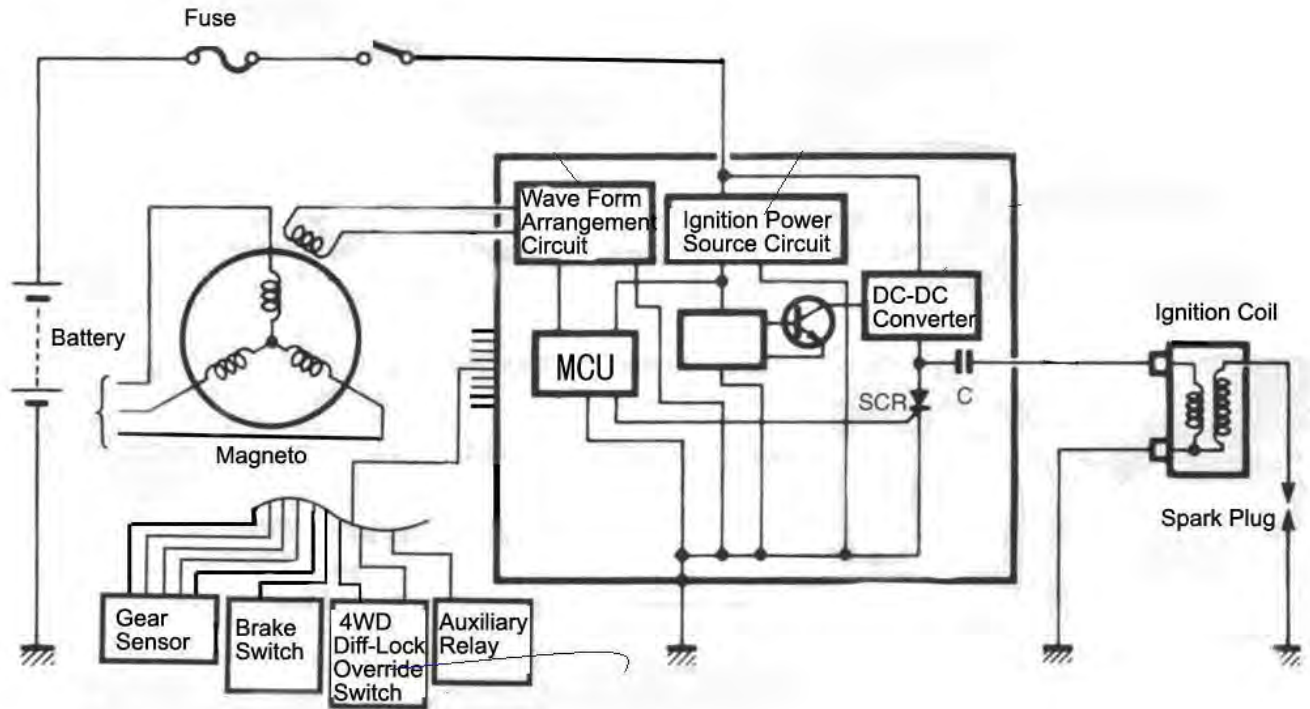

Ignition coil

Primary peak voltage of ignition coil

- Z Remove the spark plug cap as shown in the right figure. Install the new spark plug to the cap. The cylinder is connected to grounding.
- Z Connect the multimeter and the peak voltage adapter as follows:

+Probe: BK wire or grounding wire

-Probe: Br / yellow wire

NOTE:

- Z Make sure the battery voltage $\geq 12V$. The ignition coil wires are connected.
- Z When using multimeter and the peak voltage adapter, please refer to the user manual.
- Z Move the gear to the neutral position, turn on the ignition device.
- Z Press the start button and crank the engine for a few seconds. Then measure the primary peak voltage of the ignition coil;
- Z Repeat the steps above for several times. Measure the maximal value of the primary peak voltage.

Set the multimeter at the AC voltage position.

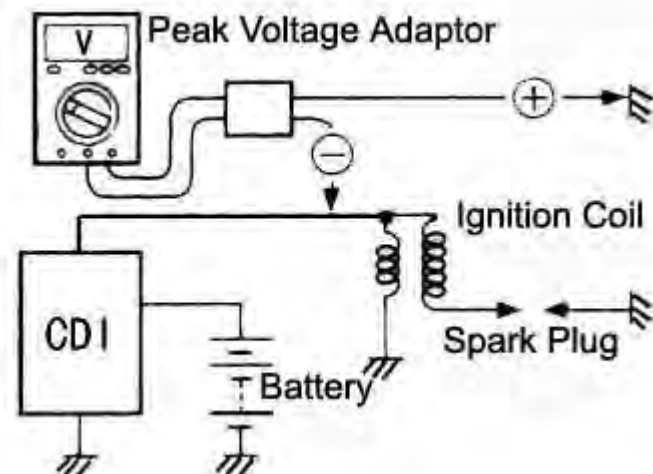

Primary peak voltage of ignition coil: $\geq 150V$

Note: Do not touch the test probes or spark plug, in case of electric shock.

Z If the voltage is lower than the standard value, check the ignition coil and coupling coil.

Resistance of ignition coil

Z Disconnect the ignition coil wires and spark plug cap. Remove the ignition coil;

Z Measure the resistance of the primary and secondary windings of the ignition coil with the multimeter. If the resistance of two coils is close to the specified value, the ignition coil is in good condition.

Resistance of ignition coil

Primary winding: $0.58 \pm 0.058 \Omega$ (terminal - ground)

Secondary coil: 7.1 ± 0.71 (terminal - spark plug cap)

Peak voltage of coupling coil

Z Check the peak voltage of the coupling coil with following steps.

Z As shown in right figure, connect the multimeter with the peak voltage adapter.

+Probe: Green/white wire

-Probe: BL/Y wire

Z Move the gear to the neutral position, turn on the ignition device.

Z Press the start button and crank the engine for a few seconds, and then measure the primary peak voltage of the coupling coil;

Z Repeat the steps above for several times. Measure the maximal value of the primary peak voltage.

Put the multi meter at AC voltage step.

Peak voltage of coupling coil: $\geq 4V$

Z If the voltage is lower than the standard value, replace coupling coil.

Resistance of coupling coil

The multi meter is put at $1 \times 100\Omega$ step.

Resistance of coupling coil: $135 \pm 5\Omega$

Z If the resistance is not within the specified value, replace the coupling coil.

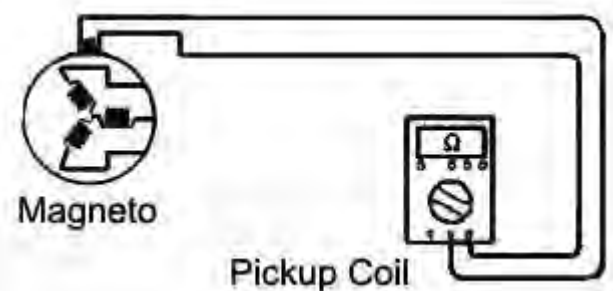
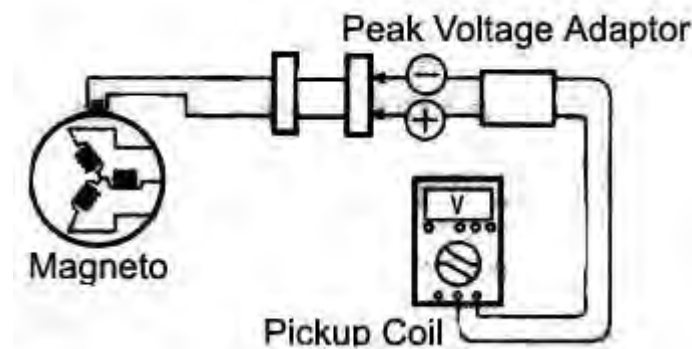
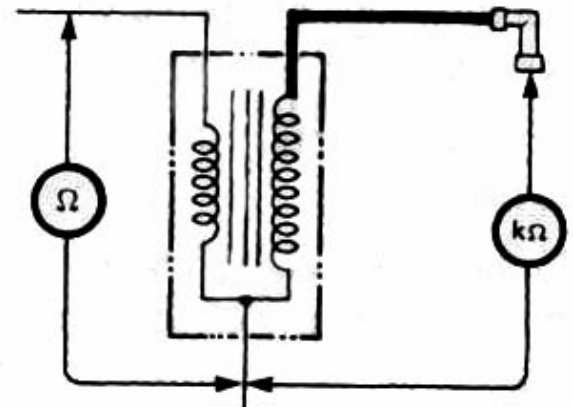

Inspecting an Electrical Connection

When replacing an electric or electronic component, always check electrical connections. Make sure they are tight, make good contact, and are corrosion-free. Dirty, loose or corroded contacts are poor conductors and are often the source of a system or component malfunction.

Pay particular attention to ensure that pins are not bent or pushed out of their connectors.

Ensure all wire terminals are properly crimped on wires, and connector housings are properly fastened.

7. TROUBLESHOOTING

ELECTRICAL SYSTEM	7-1	COOLING SYSTEM	- 7-1
MAGNETO SYSTEM	7-2	LUBRICATION	7-2
CYLINDER AND HEAD	7-3	CRANK SHAFT	7-3
GEARBOX	7-3	COUPLING UNIT	7-4
CVT	7-4	ENGINE GENERAL	7-6

ELECTRICAL SYSTEM

Symptom: NO SPARK OR POOR SPARK

1. Refer to *ignition system*.

Symptom: STARTER DOES NOT TURN

1. Refer to starting system.

Symptom: STARTER TURNS BUT DOES NOT CRANK THE ENGINE

1. Refer to starting system.
2. Check gear condition on electric starter.
 - Worn and/or damaged starter gear. Replace electric starter and/or starter drive.
3. Check condition of starter pinion gear.
 - Worn and/or damaged starter pinion and/or ring gear. Replace starter drive and/or drive pulley fixed sheave.
4. Check splines on starter drive.
 - Poor movement of pinion gear on splines. Clean and/or replace starter drive.

Symptom: STARTER TURNS BUT STARTER DRIVE DOES NOT MESH WITH RING GEAR

1. Refer to starting system.

Symptom: STARTER KEEPS RUNNING

1. Refer to starting system.

COOLING SYSTEM

Symptom: HIGH ENGINE OPERATING TEMPERATURE

1. Check coolant level.
 - Coolant level lower than recommended. Refill (refer to cooling system).
2. Check for air bubbles in cooling system.
 - Air in cooling system. Refill and bleed cooling system (refer to cooling system).
3. Check temperature sensor for electrical/mechanical failure.
 - Temperature sensor defective. Replace.
4. Check thermostat.
 - Thermostat defective (does not open when engine gets hot). Replace (refer to cooling system).
5. Check leak indicator hole (in crankcase MAG side-water pump housing area) if coolant leaks.
 - Coolant leaking from indicator hole means a damaged water pump rotary seal. Replace rotary seal (refer to cooling system).
6. Check condition of hoses and hose clamps fixation.
 - Hoses are brittle and/or hard. Replace.
 - Hose clamps are loose. Retighten clamps.
7. Check condition of impeller located on the water pump shaft.
 - Impeller wirings broken and/or impeller threads are damaged. Replace (refer to cooling system).
8. Check gasket on water pump housing.
 - Gasket on water pump housing leaks. Retighten screws and/or replace gasket.
9. Check cylinder head and/or cylinder base gasket.
 - Worn out gasket(s) is (are) causing coolant leakage. Replace.
10. Check coolant drain screw on water pump housing MAG side.
 - Copper ring on drain screw leaks. Retighten screw and/or replace copper ring.
11. Check intermediate gear(s) behind of PTO cover.
 - Worn out and/or broken gear(s) is/are causing less coolant supply. Replace worn out and/or broken gear(s) (refer to bottom end).

12. Check if water pump shaft is seized.
 - Water pump shaft does not turn. Replace defective part(s).
13. Check cooling fan and connection.
 - Fan motor faulty. Replace.
 - Wire harness is brittle or hard (no connection). Replace.
14. Check radiator fan switch and fuse.
 - Faulty fan switch and/or faulty fuse. Replace defective part(s).
15. Check radiator condition for leakage.
 - Radiator cracked or deformed. Replace radiator.
16. Check mud/dust in radiator fins.
 - Radiator fin obstructed, hard air cooling. Clean radiator fins.

MAGNETO SYSTEM

Symptom: BATTERY NOT CHARGING OR CHARGING VOLTAGE INADQUATE

1. Check battery
 - Battery shows less power. Reload battery.
2. Check magneto for damage and/or electrical failure.
 - Radial position of rotor wrong due to broken woodruff key. Replace woodruff key.
 - Coating on stator winding is damaged. Replace stator.
 - Resistance value is out of specification (refer to technical specifications). Replace magneto.
 - Connector on magneto is damaged and/or has electrical failure. Repair and clean contacts of connector.
3. Check voltage regulator/rectifier.
 - Refer to charging system.
4. Check wiring harness for cracks or other damages.
 - harness shows electrical failure and/or other damages. Replace/repair wiring harness.

LUBRICATION

Symptom: LOW OR NO OIL PRESSURE/HIGH OIL CONSUMPTION

1. Check oil level and search for leakage on crankcase and/or sealing parts.
 - Crankcase is leaking due to damage. Rebuild engine with new crankcase and gasket parts. Use recommended oil (refer to technical specifications).
 - Crankcase is leaking due to loose screws. Retighten screws with recommended torque
 - Sealing rings, O-rings and/or gaskets are brittle, hard or damaged. Replace damaged parts.
 - Piston rings worn out (blue colored engine exhaust emission). Replace piston rings (refer to cylinder and head).
 - Piston rings are broken (low compression). Replace piston rings (refer to cylinder and head).
 - Valve stem seal damaged and/or sealing lip is hard and/or brittle. Replace all valve stem seals.
2. Check oil filter for contamination.
 - Oil filter clogged. Replace oil and oil filter at the same time. Use recommended oil (refer to technical specifications).
3. Check oil drain plug on engine bottom.
 - Plug is loose and/or gasket ring is missing. Retighten the plug and/or place gasket ring.
4. Check leak indicator hole if oil leaks (in crankcase MAG side-water pump housing area).
 - Oil leaking from leak indicator hole means a damaged oil seal on water pump shaft. Replace oil seal (refer to cooling system).
5. Check oil pressure switch function.
 - Oil pressure switch damaged. Replace oil pressure switch.
6. Check oil orifice(s) on the oil pump suction side.
 - Oil orifice(s) is (are) clogged. Clean from contamination. Replace oil and oil filter if necessary (refer to maintenance or lubrication system).
7. Check oil pump function.
 - Oil pump rotor is out of wear limit. Replace oil pump (refer to lubrication system).
 - Oil pump seized due to oil leakage and/or air inclusion. Replace oil pump (refer to lubrication system).
 - Gears driving oil pump are broken or otherwise damaged. Replace gears.
 - Incorrect oil being used. Use recommended oil (refer to technical specifications).

8. Check oil pressure regulator valve (spring) function.
 - Valve spring damaged (valve always open). Replace spring.
 - Valve piston is worn or broken. Replace valve piston (refer to lubrication system).
 - Valve piston stays open due to contamination. Clean or repair valve piston.
9. Check plain bearings in crankcase for heavy wear.
 - plain bearings out of specification (increased clearance). Replace plain bearings (refer to bottom end).
10. Check engine oil strainer in crankcase.
 - Oil strainer is clogged due to contamination. Clean or replace strainer and diagnose causes. Replace possible damaged parts (refer to bottom end).

Symptom: OIL CONTAMINATION (white appearance)

1. Check leak indicator hole (in crankcase MAG side-water pump housing area) if water and oil leaks.
 - Leakage of oil/water mixture from indicator bore means damaged water pump seal ring and rotary seal. Replace sealing ring, rotary seal and change oil, oil filter and/or coolant (refer to lubrication system, cooling system and bottom end).
2. Check cylinder head and/or cylinder base gasket..
 - Gasket damaged or leaking. Retighten cylinder head with recommended torque and/or replace gasket.
3. Check tightening torque of cylinder head screws.
 - Screws not properly tightened. Retighten screws to recommended torque and replace oil.
4. Check oil for particles (may indicate possible engine internal damages).
 - Oil contamination due to metal or plastic particles. Replace possibly damaged part(s) including oil and oil filter. Use recommended oil (refer to technical specifications).

CYLINDER AND HEAD

Symptom: UNUSUAL ENGINE NOISE AND/OR VIBRATION

1. Check noise coming from cylinder head area.
 - Improper valve clearance adjustment. Readjust valve clearance and/or replace defective part(s).
 - Faulty chain tensioner. Replace spring and/or mechanism.
 - Chain guide worn out. Replace chain guide.
 - Stretched chain and/or worn out sprockets. Replace chain and sprockets.
 - Sprocket screws got loose. Retighten screws with recommended torque.
 - Rocker arm(s) is (are) worn out (valve adjustment). Readjust valve clearance and/or replace rocker arm(s).
 - Incorrect camshaft timing adjustment. Replace damaged components and readjust camshaft timing (refer to cylinder and head).

Symptom: OIL CONTAMINATION ON CYLINDER AND/OR HEAD

1. Check screws for torque.
 - Loose screws. Retighten screws with recommended torque.
 - Gaskets are brittle, hard, worn out or otherwise damaged. Replace damaged gaskets, O-rings or the V-ring on breather.

CRANKSHAFT

Symptom: UNUSUAL ENGINE NOISE AND/OR VIBRATION

1. Check noise coming from crankshaft area..
 - Crankshaft plain bearings are damaged,. Replace crankshaft plain bearings.
 - Connecting rod plain bearings are damaged. Replace connecting rod plain bearings.
 - Magneto rotor got loose. Replace damaged components and retighten rotor retaining screw with recommended torque (refer to MAGNETO SYSTEM).

GEARBOX

Symptom: UNUSUAL GEARBOX NOISE AND/OR VIBRATION

1. Check oil level in gearbox.
 - Oil leakage from gearbox. Replace damaged gasket(s) and/or oil seal(s), torque screws and refill with oil up to specified level (refer to TECHNICAL SPECIFICATIONS and GEARBOX)
2. Check bearings in the gearbox for free movement.

- Bearing(s) do(es) not move freely. Replace bearing(s)
3. Check for knocking noise.
 - Tooth of gears are damaged and/or worn. Replace respective gears.

Symptom: GEAR INDICATION FAILS.

1. Check contact screws on gear housing center.
 - Check contact screw outside for contamination and wetness. Clean contact screw and screw for wiring harness.
 - Contact(s) is (are) corroded and/or contact screw for wiring harness got loose. Clean contact surface and retighten contact screw(s) with recommended torque.
 - Wiring harness has broken cables. Replace wiring harness.
 - Shifting indicator switch(es) pin(s) is (are) worn and/or damaged. Replace shifting indicator switch(es).

Symptom: GEAR(S) IS (ARE) HARD TO SHIFT

1. Check shift shaft splines and/or shift forks for wear and/or damages.
 - Shift shaft is worn out and/or shows damaged splines. Replace shift shaft.
 - Shift drum track(s) and/or splines is (are) worn out or damaged. Replace shift drum and damaged part(s).
 - Shift fork(s) is (are) worn out and/or engagement pins are damaged. Replace shift fork(s).
 - Shift fork(s) is (are) worn out and/or fork(s) is (are) damaged. Replace shift fork(s).
 - Shift gear(s) is (are) worn out. Replace shift gear(s).
 - Shifting indicator switch(es) pin(s) is (are) worn out (no rounding on top of pin). Replace shifting indicator switch(es).
2. Check engine idle speed.
 - Check throttle cable and throttle adjustment.
 - Check bypass idle valve and connectors.
3. Check CVT one way clutch on drive pulley.
 - CVT one way clutch was not lubricated correctly. Lubricate CVT one way clutch (refer to CONTINUOUSLY VARIABLE TRANSMISSION (CVT)).
 - CVT one way clutch is worn out or damaged. Replace defective part(s) (refer to CONTINUOUSLY VARIABLE TRANSMISSION (CVT)).
 - Check if friction washer at one way clutch is worn. Replace friction washer (refer to CONTINUOUSLY VARIABLE TRANSMISSION (CVT)).
4. Check transmission lever and connecting rod.
 - Ball joint and/or ball joint nut is (are) loose. Retighten or replace the ball joint.
5. Check spring on shift shaft in gearbox.
 - Broken spring. Replace the spring (refer to GEARBOX).
6. Check for any mud intrusions.
 - CVT parts dirty. Clean all CVT parts.

COUPLING UNIT

Symptom: 4 WHEEL DRIVE INDICATION FAILS

1. Check contact screw on gear housing right side for damage and/or wear.
 - Shifting indicator switch pin is worn and/or damaged. Replace shifting indicator switch.
 - Contact is corroded and/or contact screw for wiring harness got loose. Clean contact surface and retighten contact screw with recommended torque.
 - Wiring harness has broken cable. Replace wiring harness.

Symptom: 4 WHEEL DRIVE DOES NOT ENGAGE OR DISENGAGE

1. Check actuator and/or actuator shifting fork for wear and/or damages.
 - Check if selector works properly. If so, check actuator.
 - If selector is out of specifications, check wires, connectors and/or replace selector.
 - Actuator shifting fork is worn out and/or damaged. Replace shifting fork of actuator.
 - Check function of actuator. Replace if actuator is not turning, refer to GEARBOX.
2. Check shifting sleeve splines and/or shifting fork for wear and/or damages.
 - Check sleeve shows damaged splines. Replace shifting sleeve (refer to GEARBOX).
 - Shifting fork is worn out and/or engagement pin is damaged. Replace shifting fork.

CVT

Symptom: UNUSUAL ACCELERATION BEHAVIOR

1. Check drive belt condition.
 - Belt is too narrow (drive belt engagement is higher in drive pulley).replace belt if width is

- less than specified.
2. Check lever condition on drive pulley sliding sheave and/or roller(s) on governor cup.
 - Lever(s) on drive pulley sliding sheave is (are) worn and/or damaged. Replace all levers at the same time (lever kit).
 - Roller(s) is (are) worn and/or damaged. Replace governor cup assembly.
 3. Check drive/driven pulley sliding sheave for free axial movement.
 - Sliding sheave is stuck. Replace damaged part(s).
 4. Check condition of drive/driven pulley spring.
 - Drive pulley spring tension is too smooth and/or damaged. replace spring.
 - Driven pulley spring tension is too stiff. Replace spring.
 5. Check if cam of driven pulley is worn.
 - Replace if out of specifications.
 6. Check condition of fixed and sliding sheaves (drive and driven pulley).
 - Check surface of fixed and sliding sheaves (drive and driven pulley) for grooves or other damages.
 7. Check valve adjustment.
 - Intake and/or exhaust valves are not adjusted correctly. Adjust valves.
 8. Check engine condition.
 - Low engine compression.
 9. Check ignition condition.
 - Faulty spark plug. Install new spark plug(s).
 10. Check differentials operation.
 - Vehicle on Neutral is hard to move. Repair or replace defective part(s).

Symptom: ENGINE MAXIMUM RPM IS TOO HIGH AND VEHICLE TOP SPEED IS NOT REACHED.

1. Check drive/driven pulley area for contamination and/or water intrusion.
 - CVT area is contaminated with water, dirt or oil. Clean CVT system and replace damaged part(s).
2. Check drive/driven pulley spring tension.
 - Drive pulley spring tension is too stiff. Replace spring.
 - Driven pulley spring tension is too smooth and/or damaged. Replace spring.

Symptom: DRIVE PULLEY NOISE IN IDLE SPEED

1. Check slider shoes (drive pulley).
 - Worn slider shoes (increased clearance between governor cup and drive pulley sliding sheave). Replace all slider shoes at the same time (slider shoes kit).
2. Check driven pulley sliding mechanism (between driven pulley outer and inner sheave).
 - Mechanism is stuck and/or damaged. Replace driven pulley assembly.
3. Check roller(s) and/or levers for wear (located on sliding sheave of drive pulley).
 - Roller(s) on governor cup is (are) worn out and/or damaged. Replace governor cup assembly.
 - Lever(s) on drive pulley sliding sheave is (are) worn out and/or damaged. Replace all levers at the same time (lever kit).
4. Check drive pulley screw for torque.
 - Loose screw. Retighten screw with recommended torque.
5. Check one-way clutch condition on drive pulley sliding sheave.
 - Bearing(s) do(es) not move freely. Replace damaged part(s) and lubricate inside of one-way clutch.
 - Spring sleeve(s) inside one-way clutch is (are) worn out. Replace both sleeves and springs and lubricate inside of one-way clutch.
 - Spring(s) inside one-way clutch is (are) worn out. Replace both pins and springs and lubricate inside of one-way clutch.

Symptom: DRIVE PULLEY NOISE WHEN ACCELERATING/DECELERATING

1. Check if belt runs in dry condition.
 - Drive pulley area is wet/contaminated due to water/dirt intrusion. Clean driven pulley area and/or drain water out of CVT cover.
2. Check drive/driven pulley screw for torque.
 - Loose screw on drive pulley. Retighten screw with recommended torque.
3. Check cam and driven pulley fixed sheave for wear.
 - Cam and/or drive pulley fixed sheave out of wear limit and/or damaged. Replace damaged part(s).
4. Check torque gear fixed in driven pulley sliding sheave for wear.
 - Torque gear out of wear limit and/or damaged. Replace torque gear).

5. Check for foreign particles in CVT area (stones, dirt, etc.).
 - Small particles damaged belt and/or pulley surface(s). clean system and replace damaged parts.

Symptom: VIBRATIONS ORIGINATING FROM DRIVE PULLEY

1. Check tightening torque of drive pulley screw.
 - Moving sliding sheave. Retighten screw.
2. Check fixed sheave bushings.
 - Excessive gap between bushings and fixed sheave shaft, thus restraining sliding sheave movements. Replace fixed sheave assembly.
3. Check if slider shoes are present and/or placed in correct position.
 - Slider shoe(s) is (are) missing and/or damaged. Replace all slider shoes at the same time (slider shoes kit).

Symptom: VIBRATIONS ORIGINATING FROM DRIVEN PULLEY

1. Check fixed and sliding sheave bushings on driven pulley.
 - Excessive gap between bushings and CVT shaft, thus restraining sliding sheave movements. Replace fixed and/or sliding sheave of driven pulley, polish CVT shaft area with fine emery cloth and wipe clean with a cloth.

Symptom: PULLEYS DO NOT DOWN/UP SHIFT PROPERLY.

1. Check drive pulley bushings (cleanliness, wear, etc.)
 - Check items 1 and 2 of UNUSUAL ACCELERATION BEHAVIOR.
 - Bushings stick to fixed sheave pulley shaft. Clean or replace.
 - Spring seat sticks to sliding sheave pulley bushing. Clean system and/or replace sliding sheave pulley.
 - One-way clutch does not operate properly. Clean system and/or replace damaged part(s).
2. Check driven pulley spring tension.
 - Driven pulley spring tension is too weak or broken. Replace.
 - Driven pulley cam is worn or damaged. Replace.

Symptom: BELT GLAZED EXCESSIVELY OR HAVING BAKED APPEARANCE

1. Check if CVT air intake and/or outlet is clogged.
 - CVT area heats up due to contamination. Clean air intake and/or outlet from contamination.
 - Fans located on drive pulley is worn or damaged. Replace.
2. Check if pulley sheaves are clean.
 - Oil on pulley surfaces. Clean pulley sheaves and replace belt.
 - Water intrusion in CVT area. Find root cause and repair. Drain water and replace belt.

Symptom: BELT WORN EXCESSIVELY IN TOP WIDTH.

1. Check drive belt width.
 - Considerable wear. Replace belt if narrower than specified (refer to CONTINUOUSLY VARIABLE TRANSMISSION (CVT) OR TECHNICAL SPECIFICATIONS).
2. Check driver belt identification number.
 - Wrong type of belt. Replace belt with an appropriate drive belt.
3. Check for localized belt wear caused by belt slippage.
 - Localized wear. Replace belt.

Symptom: BELT DISINTEGRATION.

1. Check drive belt lifetime is exceeded..
 - Clean CVT system and rebuild with a new drive belt.
2. Check drive belt identification number.
 - Excessive belt speed. Using unspecified type of belt. Replace belt with proper type of belt.
3. Check if pulley sheaves are clean.
 - Oil on pulley surfaces. Clean pulley surfaces with fine emery cloth and wipe clean using pulley flange cleaner and a cloth.
 - Drive/driven pulley sheaves are damaged through stones inside CVT area. Clean pulley surfaces with fine emery cloth, wipe clean with a cloth or replace drive/driven pulley sheaves and belt.

Symptom: BACK BETWEEN COGS

1. Check drive belt condition.
 - Considerable use, belt wearing out. Replace.
 - Brittle belt condition through aging. Replace belt.

ENGINE GENERAL

Symptom: ENGINE CRANKS BUT FAIL TO START

1. Check if spark plug connectors fit on spark plugs (refer to IGNITION SYSTEM).
2. Check spark plugs.
 - Define spark plugs (no spark) or wrong spark plug gap. Readjust gap and clean spark plugs or replace.
3. Check for fuel on spark plugs.
 - Flooded engine (spark plugs wet when removed). Activate engine drowned mode and crank engine with rags over the spark plug holes.
4. Check battery voltage.
 - Battery is discharged and starter works not properly. Charge battery.
5. Check fuel level in fuel tank and fuel pressure. Ensure fuel pump was not disabled.
 - Low or no fuel pressure. Replace defective part(s).
6. Check fuel injectors.
 - Plugged or faulty injector(s). Replace defective part(s).
7. Check idle bypass valve.
 - Stuck or defective..
8. Check encoder wheel.
 - Bent tooth. Refer to MAGNETO SYSTEM.
9. Check engine compression.
 - Insufficient engine compression. Replace defective part(s).
10. Check fault codes in B.U.D.S. system.
 - Check if electrical actuator(s) is/are defective. Replace defective part(s) (refer to COMPONENT INSPECTION AND ADJUSTMENT).

Symptom: ENGINE DOES NOT START

1. Electrical problem.
 - Determine if the electrical system works correctly (fuse(s), battery, wiring harness, etc.). refer to IGNITION SYSTEM.
2. Problem with fuel system (carburetor, fuel pump, hoses, etc.).
 - Clean, inspect, repair or replace defective parts. Replace defective part(s).
3. Check engine compression.
 - Insufficient engine compression. Replace defective parts.
 - Valve seat worn and/or damaged. Repair by performing valve guide procedure (refer to CYLINDER AND HEAD). Readjust valve clearance.
4. Internal engine problem.
 - Overhaul engine to find defective parts. Refer to the appropriate section in ENGINE.

Symptom: ENGINE HARD TO START

1. Check idle bypass valve.
 - Stuck or defective. Refer to ENGINE MANAGEMENT.
2. Check closed throttle and idle actuator with B.U.D.S.
 - Wrong TPS zero setting/idle bypass valve reset. Refer to ENGINE MANAGEMENT.
3. Check engine compression.
 - Wrong adjustment (likely too tight). Refer to ENGINE MANAGEMENT.
4. Check engine compression.
 - Insufficient engine compression. Replace defective part(s) refer to LEAK TEST.
5. Verify spark plug condition.
 - Defective, improperly set, worn out, fouled. Identify source of problem and correct. Replace.
6. Check fuel level in fuel tank and fuel pressure.
 - Low or no fuel pressure. Replace defective part(s) refer to FUEL TANK AND FUEL PUMP.
7. Check CAPS (camshaft position sensor).
 - Defective sensor/wiring. Refer to ENGINE MANAGEMENT.

Symptom: ENGINE SUDDENLY TURNS OFF

1. Perform engine leak test.
 - Damaged head gasket and/or seal and/or leaking inlet/exhaust valve(s). replace and/or repair defective parts.
2. Check spark plugs condition and/or gap.
 - Fouled spark plugs or wrong spark plug gap. Readjust gap and clean spark plugs or replace..
3. Piston seizure.
 - Spark plugs heat range is too hot. Install spark plugs with appropriate heat range (refer to

- TECHNICAL SPECIFICATIONS).
- Compression ratio is too high. Install genuine parts.
 - Poor oil quality. Use recommended oil.
 - Leaks at air intake manifold (engine gets too lean). Retighten screws or replace air intake manifold gasket.
 - Snow/water intrusion through intake system into combustion chamber. Clean intake system and replace defective part(s).
4. Melted and/or perforated piston dome; melted section at ring end gap.
 - Spark plugs heat range is too hot. Install recommended spark plugs (refer to TECHNICAL SPECIFICATIONS).
 - Coolant less than recommended level (engine gets too hot). Repair cooling circuit and/or refill with recommended liquid.
 - Poor quality and/or wrong fuel. Clean from contamination and use appropriate fuel (refer to TECHNICAL SPECIFICATIONS).
 5. Piston color is dark due to seizure on intake and exhaust side.
 - Cooling system leaks and lowers coolant level. Tighten clamps or replace defective parts. Add antifreeze in cooling system until appropriate level is reached. Replace damaged parts.
 6. Cracked or broken piston.
 - Cracked or broken piston due to excessive piston/cylinder clearance or engine overheating. Replace piston. Check piston/cylinder clearance (refer to CYLINDER AND HEAD).
 7. Check piston rings and cylinder surface for grooves.
 - Poor oil quality. Use recommended oil.
 - Contamination through engine intake. Replace defective part(s) and use new air filter.
 8. Check crankshaft, rocker arms movement.
 - Oil pump failure due to lack of oil. Repair and replace defective parts and use new recommended oil.
 - Oil contamination due to clogged oil filter/oil strainer. Replace oil and oil filter at the same time, replace defective part(s).
 9. Check valve springs exhaust/intake.
 - Broken valve spring damages the cylinder head, valve(s), rocker arm(s), piston, piston rings and connecting rod. Replace defective part(s).
 10. Check if fuel supply is sufficient.
 - Low fuel level.
 - Clogged fuel filter or fuel injector filter.
 - Fuel line is contaminated and/or bent. Clean and/or replace defective part(s).

Symptom: ENGINE BACKFIRES

1. Check spark plugs.
 - Carbon accumulation caused by defective spark plugs. Replace spark plugs.
2. Check leakage on intake manifold.
 - Air leak on intake system. Retighten screws and/or replace intake manifold gasket.
3. Check exhaust air leaking.
 - Exhaust gasket is leaking. Retighten screws and/or replace exhaust gasket.
4. Check intake valve(s) for leaking.
 - Intake valve(s) is (are) leaking. Repair or replace valve(s).
5. Check if fuel supply is sufficient.
 - Fuel line is contaminated and/or bent (engine gets lean). Clean and/or replace defective part(s).
6. Check engine ground.
 - Poor engine ground. Clean.

Symptom: ENGINE DOES NOT OFFER MAXIMUM POWER AND/OR DOES NOT REACH MAXIMUM OPERATING RPM

1. Check spark plugs condition and/or gap.
 - Fouled spark plugs or wrong spark plug gap. Readjust gap and clean spark plugs or replace.
2. Check spark plugs type.
 - Improper spark plugs heat range. Install recommended spark plugs (refer to TECHNICAL SPECIFICATIONS).
3. Perform engine leak test.
 - Damaged head gasket and/or seal and/or leaking intake/exhaust valve(s). replace and/or repair defective parts.

4. Check for water in fuel (wrong fuel).
 - There is water in fuel or wrong fuel. Drain fuel system, search for leakage and refill it with appropriate fuel.
5. Check engine compression.
 - Worn piston(s) and/or piston ring(s). Replace defective part(s).
6. Check fuel pressure.
 - Low fuel pressure. Perform fuel pressure test (refer to FUEL SYSTEM).
7. Check air intake system.
 - Air filter is clogged due to contamination. Replace air filter.
8. Check if EMS (engine management system) is in limp home mode. Check fault codes in B.U.D.S. system.
 - Check if electrical actuator(s) is/are defective. Replace defective part(s).
9. Check drive belt.
 - Worn. Replace belt if its width is less than specified.

Symptom: HIGH ENGINE OPERATING TEMPERATURE

1. Check if cooling system shows any failure (see COOLING SYSTEM).
 - System is leaking. Repair and/or replace damaged part(s).
2. Check function of lubrication system (see LUBRICATION SYSTEM).
 - Lubrication is not working properly. Repair and/or replace damaged part(s).
3. Check condition and heat range of spark plugs.
 - Melted spark plug tip or inadequate heat range. Replace.
4. Check air leakage on engine intake.
 - Leakage causes overheating. Replace/repair damaged part(s).
5. Check air inlet and outlet of the CVT cover.
 - Air circulation is clogged (overheating). Clean air circulation from contamination.
 - Drive belt worn and/or damaged. Replace belt with an appropriate drive belt (refer to TECHNICAL SPECIFICATIONS).