

UTV Junglecross 1000 LT Series

Maintenance Manual



Shandong ODES Industry Co. Ltd.

Any copy or without written permission or authorization is prohibited to use the manual (version 2, May 2020).

All rights reserved

Foreword

This manual contains such content as introductions on overhaul, maintenance, overhauling program, dismantling, assembling, troubleshooting and service data of UTV1000-3/4

This manual will help you know the vehicle better so that you can assure your customers of fast and reliable service.

This manual has been prepared on the basis of the latest specifications at the time of publication. If modifications have been made since then, differences may exist between the content of this manual and the actual vehicle.

Illustrations in this manual are used to show the basic principles of operation and work procedures. They may not represent the actual vehicle exactly in detail.

Manufacturer reserves the right of no prior notice on product improvement or modification. Repair and maintenance shall be carried out according to actual situation of vehicle.

WARNING

Inexperienced mechanics or mechanics without the proper tools and equipment may not be able to properly perform the services described in this manual.

Improper repair may result in injury to the mechanic and may render the vehicle unsafe for the rider.

GROUP INDEX	
GENERAL INFORMATION	1
PERIODIC MAINTENANCE	2
ENGINE	3
COOLING SYSTEM	4
FUEL SYSTEM	5
DRIVE TRAIN	6
STEERING SYSTEM	7
SUSPENSION SYSTEM	8
BRAKES SYSTEM	9
ELECTRICAL SYSTEM	10
TROUBLE SHOOTING	11

1. GENERAL INFORMATION

PRECAUTIONS..... 1-1	TECHNICAL SPECIFICATIONS.....1-3
TIGHTENING TORQUE.....1-6	

PRECAUTIONS

1. Do not make engine under operation at a closed place or place with poor ventilation for a long time.
2. If engine stops operation, please do not touch it or silencer to avoid burning.
3. Due to high corrosive, battery fluid (dilute sulfuric acid) may cause burns to skin and eyes. In case of splashing it to skin, please clean it with water and see the doctor immediately. In case of splashing it to clothes, please wash it with water immediately. Keep battery fluid far away from Children.
4. Cooling liquid is toxic. Do not drink it or splash it to skin, eyes and clothes. once splashing it to skin, please wash it with a lot of soapy water. In case of splashing it to eyes, please wash eyes immediately and see the doctor. In case of drinking cooling liquid, resulting in vomit, please see the doctor. Keep cooling liquid far away from children.
5. Wear proper working suit, boots and hat. If necessary, please wear long-sleeve working suit and gloves for operation.
6. Gasoline is highly inflammable. No smoking or firing. At the same time, fire sparks shall be avoided. Vaporized gasoline is explosive as well. Operation shall be carried out at places with good ventilation.
7. Battery may produce explosive hydrogen in charging. Please ensure charging at places with good ventilation.
8. Use legal parts, lubricating oil and lubricating grease.
9. Before overhauling, please clean soil and dust.
10. Keep accessories of each part well for correct assembly.
11. Replace dismantled gasket, O-shaped ring, piston pin retainer and cotter pin.
12. Retainer of rubber ring may be deformed after dismantling. So, please do not use loose and soft retainer.
13. Please wash and dry dismantled parts. Use lubricant on the surface of moving parts. For correct installation, please measure data well in dismantling process.
14. If do not know length of screw, please install screws one by one to ensure their corresponding depth.
15. Pre-tighten bolts and nuts and then tighten them with designated torque from the big to the small and from the inside to the outside.

16. Check whether rubber parts are aged. If necessary, replace them. Keep rubber parts far away from grease.
17. If necessary, special tools can be used.
18. Rotate inside and outside races of bearing to ensure flexibility of balls.
 - a) If axial or radial resistance is too large, please replace it. If there is concave-convex on the surface, please use oil for washing. If no effect is achieved with washing, please replace it.
 - b) If bearing cannot be clamped tightly in pressing into machine or axle, please replace bearing.
19. Please install a side dust proof bearing at correct direction. In installation of open or double-face dust proof bearing, pay attention to that marks of manufacturer shall be outward.
20. In cleaning and drying bearing, please keep bearing support still. Before installation, please carry out lubrication with oil or lubricating oil.
21. Please correct install elastic retaining ring. Assembling after opening can ensure installation of snap ring into slot.
22. After assembly, please check whether all parts are of perfect tightening and flexible movement.
23. Brake fluid and coolant may damage shell and plastic and rubber parts. In case of being splashed by them, please use water for washing.
24. In installing pipeline, please insert them to bottom of connecting pipeline. In installing pipe clamp, please install them to groove if there is. As for pipeline or pipe clamp that cannot be tightened, please replace them.
25. Do not mix soil or dust into engine and/or hydraulic braking system.
26. Before installation, please clean gasket and spacer of engine shell. Use oil stone to polish scratch of joint face evenly.
27. Do not twist or bend too much cable. Twisted or damaged cables may cause inflexible operation.

TECHNICAL SPECIFICATIONS

Item	Parameter	
	UTV1000-3A	UTV1000-4A
Dimensions		
Overall length	3075mm (121.06in)	3875mm(152.56in)
Overall width	1730mm(68.11in)	1730mm(68.11in)
Overall height	2060mm(81.10in)	2060mm(81.10in)
Seat height	850mm(33.46in)	850mm(33.46in)
Wheelbase	2035mm(80.12in)	2035mm(80.12in)
Ground clearance	450mm(17.72in)	450mm(17.72in)
Engine		
Type	Two-cylinder, 4-stroke,SOHC, water cooling,	
Number of valves	8(mechanical adjustment)	
Cylinder diameter	91 mm(3.58in)	
Piston stroke	75 mm(2.95in)	
Compression ratio	10.3: 1	
Displacement	976ml	
Maximum power	63.7kw/6500RPM	
Maximum torque	100N.m/5500RPM	
Idle speed	1250rpm	
Lubrication	Type	Wet tank lubrication, oil filters can be changed
	Oil pressure	0.07-0.25MPa at 1250rpm
	Type of oil	SAE10W-50/SJ
	Oil quantity	2200mL
	Replacement of capacity	2000mL
Fuel	Type	Unleaded gasoline only 93# or higher
	Fuel pressure	350 KPa
	Fuel tank capacity	37L
Valve clearance	Intake	0.06 to 0.10mm(0.00236in to 0.0039in)
	Exhaust	0.11 to 0.15mm(0.0043in to 0.0059in)
Diameter of valve rod (IN)	New	4.966 to4.980mm(0.1955in to 0.1961in)
	Service limit	4.930mm(0.1941in)
Diameter of valve rod (EX)	New	4.956 to 4.970mm(0.1951in to 0.1957in)
	Service limit	4.930mm(0.1941in)
Valve seat contact width (IN)	New	1.05 to 1.35mm(0.0414in to 0.0531in)
	Service limit	1.80mm(0.0709in)

1.GENERAL INFORMATION

Valve seat contact width (EX)	New	1.25 to 1.55mm(0.049in to 0.061in)
	Service limit	2.00mm(0.0787in)
Valve guide diameter	New	4.998to 5.018mm(0.1968in 0.1976in)
	Service limit	5.050mm(0.1989in)
Free length of valve spring	New	40.81mm(1.607in)
	Service limit	39mm(1.535in)
Rocker arm bore diameter	New	12 .036to 12.050mm(0.4739in to 0.4745in)
	Service limit	12.060mm(0.4748in)
Rocker arm shaft diameter	New	12.00 to 12.018(0.4724in to 0.4731in)
	Service limit	11.990mm(0.472in)
Piston measurement	New	90.950 to 90.966mm(3.581in to 3.5813in)
	Service limit	90.850mm(3.5768in)
Cylinder measurement	Size "A"	91.955 to 91.003mm(3.6203in to 3.5828in)
	Size "B"	91.0031 to 91.010mm(3.5828in to 3.583in)
Intake cam height	New	32.96 to 33.16mm(1.2977in to 1.3055in)
	Service limit	32.94mm(1.2969in)
Exhaust take cam height	New	32.86mm to 33.06mm(1.2937in to 1.3016in)
	Service limit	32.84mm(1.2929in)
Crankshaft main journal diameter	New	42.024 to 42.040mm(1.6545in to 1.6551in)
	Service limit	42.000mm(1.6535in)
Crankshaft radial clearance	Service limit	0.06mm(0.0024in)
Crankshaft deflection	Service limit	0.07mm(0.0028in)
Crankshaft pin diameter	New	41.986 to 42.010mm(1.6530in to 1.6539in)
	Service limit	41.967mm(1.6522in)
Connecting rod big end radial clearance	Service limit	0.09mm(0.0035in)
Connecting rod small end diameter	New	22.010 to 22.020mm(0.8665in to 0.8669in)
	Service limit	22.050mm(0.8681in)
Piston pin diameter	New	21.996 to 22.00mm(0.8660in)
	Service limit	21.980mm(0.865in)
Spark plug	Type/manufacturer	NGK CPR8EA-9
	Gap	0.7-0.9mm (0.0276 to 0.0354in)
Transmission type		CVT(Continuously Variable Transmission)
Continuously variable ratio		0.63to3.06
Drive belt width	Service limit	30.00mm
Gearbox type		Dual range(H/L) with park, neutral and reverse
Gearbox oil	Capacity	450mL(GL-4-90)

1.GENERAL INFORMATION

Gear ratio	H	3.36
	L	5.84
	R	7.15
Cooling liquid temperature thermostat	Valve opening	65C°
	Fan opening	82C°
Magneto generator output		520W@6000rpm
Crankshaft position sensor value of resistance		774 to 946 Ω@20°C
Tire		
Type		Tubeless
Pressure		97 to 124KPa
Size Front		29×8–15
Size Rear		29×10–15
Brakes		
System		Front and rear unified
Type Front		Dual disc brake
Type Rear		Dual disc brake
New disk thickness		4.0mm(0.1575in)(Front) 3.5mm(0.1378in)(Rear)
Minimum disk thickness		3.5mm(0.1378in)(Front) 3.0mm(0.1181in)(Rear)
Maximum disk warpage		0.2mm(0.0079in)
Operation		Foot operation
Suspension and shock absorber		
Front suspension		Double wishbone
Rear suspension		Double wishbone
Front shock absorber		Coil spring / oil damper
Front shock absorber travel		120mm(4.724in)
Rear shock absorber		Coil spring / oil damper
Rear shock absorber travel		135mm(5.315in)
Drive train		
Front differential		Shaft driven/single auto-lock differential
Front differential ratio		3.67:1
Rear axle		Shaft driven/single differential
Rear axle ratio		3.67:1
Front differential oil capacity		180mL(GL-4-90)
Rear differential oil capacity		220mL(GL-4-90)

Electrical		
Ignition system		EFI-DELPHI
Battery	Type	Maintenance Free
	Voltage	12V
	capacity	45AH
Fuses	Reversing Light	10A
	Fan	30A
	Lock(second shift)	20A
	Reserve power	15A
	EFI system meter	25A
	Lighting	30A
	EPS	40A
	Rear drive control	15A
	Electric top	15A
	Top light	20A
	Seat heating	15A
Head lamp (High beam / low beam)		12V55W/55W&12V 30W/20W
Fog light		Front: 12V0.4W&12V 6W Rear: 12V0.35W
Stoplight		12V 1.8W
Indicator light		Front: 12V 0.35W Rear: 12V 0.4W
Turn light		Front: 12V 5W Rear: 12V 1.8W

TIGHTENING TORQUE

Locking devices (e.g.: locking tabs, elastic stop nuts ,self-locking fasteners ,etc.) must be installed or replaced with new ones, where specified. If the efficiency of a locking device is impaired, it must be renewed.

In order to avoid a poor assembling, tighten screws, bolts or nuts in accordance with the following recommended torque value:

Grade	Torque(N·m)					
	M6	M8	M10	M12	M14	M16
4.6	4~5	10~12	20~25	36~45	55~70	90~110
5.6	5~7	12~15	25~32	45~55	70~90	110~140
6.8	7~9	17~23	33~45	58~78	93~124	145~193
8.8	9~12	22~30	45~59	78~104	124~165	193~257
10.9	13~16	30~36	65~78	110~130	180~201	280~330
12.9	16~21	38~51	75~100	131~175	209~278	326~434

CAUTION

Be sure to use the proper tightening torque for the proper strength grade. Always torque screws, bolts and / or nuts in a crisscross sequence.

As for important tightening torques , please refer to following standards.

Installation location	Specifications (mm)	Torque N.m(ft.lbs)
Fastening bolt of engine	M10	60-65(44.3-48)
Fastening nut of suspension arm	M12	78-100(57.6-73.8)
Bolt of rear shock absorber	M12	78-100(57.6-73.8)
Bolt of front shock absorber	M12	80(59)
Fastening nut of wheel rim	M12	100(73.8)
Nut of wheel hub	M22	300(221.4)
Bolt of rear brake/stop pump (calipers)	M10	80(59)
Bolt of brake/stop disc	M8	26(19.2)
Bolt of front brake/stop pump (calipers)	M10	80(59)
Lock nut of steering rod	M12	80(59)
Lock bolt of steering gearbox	M12	140(103.3)
Bolt of exhaust pipe	M8	30(22.1)
Fastening bolt of rear differential	M10	80(59)
Fastening bolt of front differential	M10	80(59)
Bolt of front propeller shaft flange	M8	40(29.5)
Bolt of front propeller shaft flange	M10	80(59)
Bolt of rear propeller shaft flange	M10	80(59)
Spark plug	M12	20(14.76)
Water temperature sensor	M12	16(11.8)
Oil pressure switch	M10	12(8.9)
Adjusting nut of valve clearance	M6	12(8.9)
Main pulley bolt	M12	100(73.8)
Driven pulley bolt	M10	60(44.28)
Magneto flywheel bolt	M16	150(110.7)
Magneto stator bolt	M6	12.5(9.23)
One way bolt	M8	30(22.1)
Engine oil drain plug	M12	20(14.76)
Gearbox oil drain plug	M12	20(14.76)
Decompression valve plug	M22	20(14.76)
Cylinder head bolt	M10	60(44.28)
Cylinder head bolt	M6	12.5(9.23)
Connecting rod bolt	M8	50(36.9)
Timing chain wheel bolt	M8	30(22.14)
Front output shaft flange bolt	M8	30(22.14)
Rear output shaft flange bolt	M10	60(44.28)

2. PERIODIC MAINTENANCE

MAINTENANCE SCHEDULE	2-1	AIR CLEANER	—	2-3
VALVE CLEARANCE	2-4	SPARK PLUG	—	2-7
THROTTLE CABLE PLAY	2-8	ENGINE OIL	—	2-9
FRONT DIFFERENTIAL OIL	2-11	REAR DIFFERENTIAL OIL		2-12
STEERING SYSTEM	2-12	BRAKING SYSTEM		2-14
GEAR SHIFT	—	2-15		2-15
WHEELS	—	2-18		2-19
ENGINE OIL PRESSURE	2-20	SUSPENSION SYSTEM		2-21

MAINTENANCE SCHEDULE

In order to maintain the best performance and economical performance of vehicles, suggestions on intervals for necessary regular maintenance are listed. Following maintenance is calculated in km, mile and hour based on firstly appeared data.

However, keep in mind that if the vehicle isn't used for a long period of time, the month maintenance intervals should be followed.

Items marked with an asterisk should be performed by a dealer as they require special tools and technical skills.

In case of complicated road conditions, regular maintenance shall be carried for vehicles.

ITEM	ROUTINE	Whichever Comes first ⇒	INITIAL			EVERY		
			month	1	3	6	6	12
			Km (mi)	320 (200)	1200 (750)	2400 (1500)	2400 (1500)	4800 (3000)
			hours	20	75	150	150	300
Valves*	<ul style="list-style-type: none"> • Check valve clearance. • Adjust if necessary. 		○		○	○	○	
Cooling system	<ul style="list-style-type: none"> • Check coolant leakage. • Repair if necessary. • Replace coolant every 24 months. 		○	○	○	○	○	
Spark plug	<ul style="list-style-type: none"> • Check condition. • Adjust gap and clean. • Replacement every 24 months 		○	○	○	○	○	
Air filter elements	<ul style="list-style-type: none"> • Clean. • Replacement every 24 months 		Every 20-40 hours (More often in dusty areas)					
Crankcase breather system*	<ul style="list-style-type: none"> • Check breather hose for cracks or damage. • Replace if necessary. 				○	○	○	
Exhaust system*	<ul style="list-style-type: none"> • Check for leakage. • Tighten if necessary. • Replace gasket(s) if necessary. 				○	○	○	

2.PERIODIC MAINTENANCE

Fuel line*	<ul style="list-style-type: none"> ● Check fuel hose for cracks or damage.. ● Replacement fuel hose every 48 months ● Replacement fuel filter every 24 months 			O	O	O
Engine oil	<ul style="list-style-type: none"> ● Replace (Check oil level every month) . 	O		O	O	O
Engine oil filter	<ul style="list-style-type: none"> ● Replace. 	O		O		O
Differential and gearbox oil	<ul style="list-style-type: none"> ● Check oil level/oil leakage. ● Replacement every 24 months. 	O				O
Brake*	<ul style="list-style-type: none"> ●Check operation/brake pad wear/fluid leakage. ●Brake fluid needs to be above the lowest position. ●Correct if necessary. Replace pads/disk if worn to the limit. 	O	O	O	O	O
Accelerator pedal*	<ul style="list-style-type: none"> ●Check operation and free play. 	O	O	O	O	O
Wheels*	<ul style="list-style-type: none"> ●Check balance/damage/ run out ●Repair if necessary. 	O		O	O	O
Wheel bearings*	<ul style="list-style-type: none"> ●Check bearing assemblies for looseness or damage.. ●Replace if damaged. 	O		O	O	O
Front and rear Suspension*	<ul style="list-style-type: none"> ●Check no deformation and looseness. ●Correct if necessary. 			O		O
Steering system*	<ul style="list-style-type: none"> ●Check operation and no looseness. ●Repair if damage. ●Check toe-in/Adjust if necessary. 	O	O	O	O	O
Rear knuckle pivots and suspension arms*	<ul style="list-style-type: none"> ●Lubricate with lithium-soap-based grease. 			O	O	O
Drive shaft universal joint*	<ul style="list-style-type: none"> ●Lubricate with lithium-soap-based grease. 			O	O	O
Engine mount*	<ul style="list-style-type: none"> ●Check for cracks or damage. ●Correct bolt tightness. 			O	O	O
Front and rear axle boots*	<ul style="list-style-type: none"> ●Check operation. ●Replace if damage. 	O				O
Stabilizer bushings*	<ul style="list-style-type: none"> ●Check for cracks or damage. 			O	O	O
Fittings and fasteners*	<ul style="list-style-type: none"> ●Check all chassis fittings and fasteners. ●Correct if necessary. 	O	O	O	O	O
Battery	<ul style="list-style-type: none"> ●End connection 	O		O	O	O
Lamp and steering indication	<ul style="list-style-type: none"> ●Operation 	O	O	O	O	O

AIR CLEANER

In case of driving in dusty environment, air filter shall be cleaned regularly. It is of great possibility to accelerate wear to engine if there is not filtering element or worn filtering element is used. So, please keep air filter under good conditions all the time. If vehicle is used in dusty area, inspect more frequently than specified in MAINTENANCE SCHEDULE.

If the air cleaner is clogged with dust,intake resistance will be increased,with a resultant decrease in power output and an increase in fuel consumption. never remove or modify any component in the air filter housing. The engine management system is calibrated to operate specifically with these components. Otherwise, engine performance degradation or damage can occur.Check and clean the air cleaner element in the following manner:

Remove two rear screws and then remove the filter box cover .



Release 4 clamps and remove air filter housing cover.
CAUTION:PREVENT CLAMPS FROM FALLING.



Loosen clamp and remove air filter.



Blow low pressure compressed air on filter element to clean it.



Properly re-install removed parts in the reverse order of their removal. pay attention to the seal gasket of air filter housing is not skew.

CAUTION

1. If liquid /deposits are found, squeeze and dry the foam filter.
Replace filter element if damaged.
2. Do not start engine if liquid or deposit are found. If there is oil in the air filter housing, check engine oil level. Oil level or temperature may be too high.
3. Inspect the air cleaner element for tears, a torn element must be replaced.

VALVE CLEARANCE

Excessive valve clearance results in valve noise and insufficient valve clearance results in valve damage and reduced power.

Check the intake and exhaust valve clearances at the distances indicated above and adjust the valve clearances to specification,if necessary.

Valve clearance is to be checked when the engine is cold.The intake and exhaust valves must be checked an adjusted when the piston is at TOP-DEAD –CENTER(TDC) on the compression stroke.

Remove left and right seats, gear shift handle and engine shield.



Remove spark plug cable and spark plug of both cylinders.

Remove the valve cover of both cylinders .

1. screws
2. Valve cover

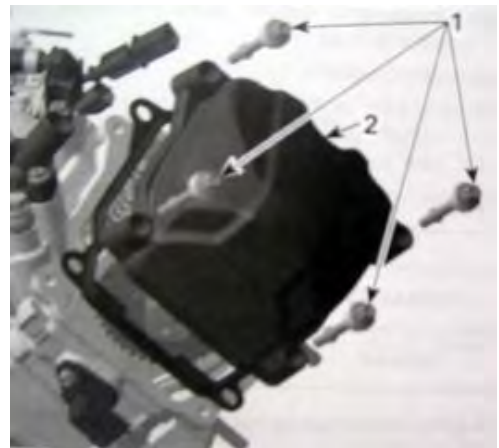

Remove the plug screw and O-ring of magneto cover.

Remove the crankshaft position sensor.

1. Crankshaft position sensor
2. Screw



Valve clearance of cylinder 2

Use a 14 mm Allen key to turn crankshaft until piston 2, rear is at TDC ignition.

When rear piston is at TDC ignition, marks on magneto flywheel "2" and on the magneto cover are aligned.

1. Mark "2" on magneto flywheel
2. Notch on magneto cover
3. Crankshaft position sensor location

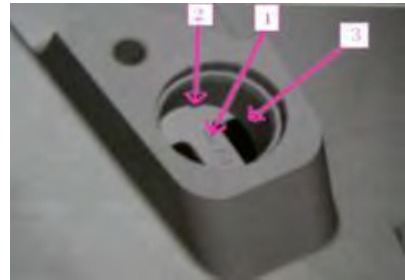

At TDC ignition, the printed marks on the camshaft timing gear have to be parallel to cylinder head base. If not, use Allen key to turn crankshaft 360°

1. Printed marks on camshaft timing gear
2. Cylinder head base



Insert the feeler gauge between the valve stem end and adjusting screw on the rocker arm to check the clearance.

If the valve clearance is out of specification, adjust valves as follows.

Valve clearance	
Intake	0.06 to 0.10mm(0.00236 to 0.00394 inches)
Exhaust	0.11 to 0.15mm(0.00433 to 0.00591 inches)

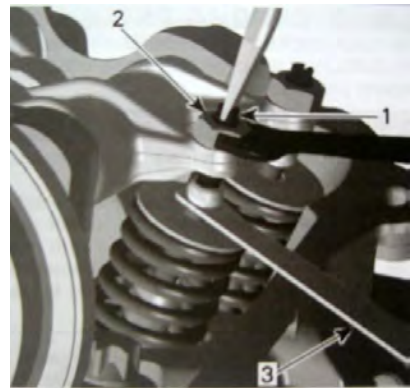

Use mean valve of exhaust/intake to ensure a proper valve adjustment.

Hold the adjustment screw at the proper position and torque the locking nut.

Repeat the procedure for each valve.

1. Adjustment screw
2. Adjustment nut
3. Feeler gauge

CAUTION

Securely tighten the locknut after completing adjustment.

Valve clearance adjustment locknut: 12N.m(8.856Lbf.ft)**Valve clearance of cylinder 1**

Using a 14 mm Allen key, turn crankshaft 280 °counterclockwise.

1. Allen key 14mm
2. Turn crankshaft 280°counterclockwise



Until marks on magneto flywheel "1" and magneto cover are aligned.

1. Mark "1" on magneto flywheel
2. Notch on magneto cover
3. Location of crankshaft position sensor

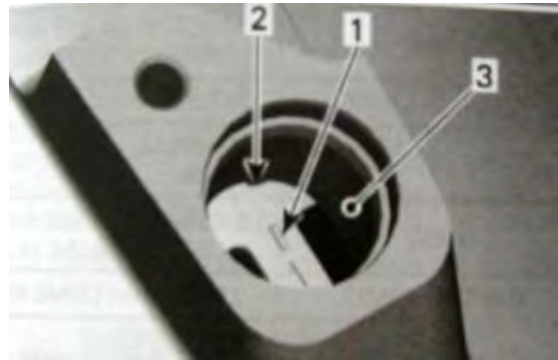

At TDC ignition, the printed marks on the camshaft timing gear have to be parallel to cylinder head base as per following illustration.

TYPICAL

1. Printed marks on camshaft timing gear
2. Cylinder head base

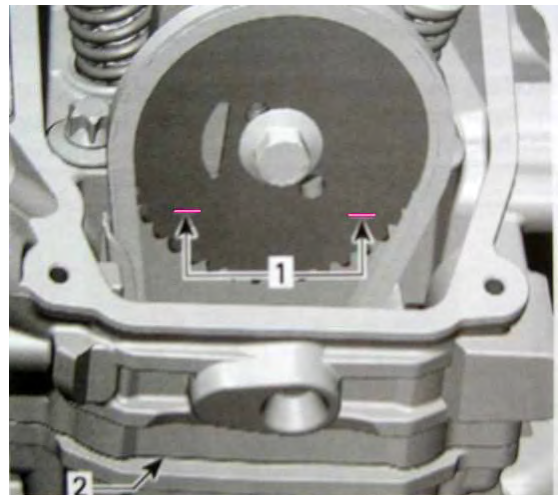

Insert the feeler gauge between the valve stem end and adjusting screw on the rocker arm to check the clearance.

If the valve clearance is out of specification, adjust valves as follows.

Valve clearance	
Intake	0.06 to 0.10mm (0.00236 to 0.00394 inches)
Exhaust	0.11 to 0.15mm (0.00433 to 0.00591 inches)

Use mean valve of exhaust/intake to ensure a proper valve adjustment.

Hold the adjustment screw at the proper position and torque the locking nut.

Repeat the procedure for each valve.

1. Adjustment screw
2. Adjustment nut
3. Feeler gauge

Valve clearance adjuster locknut:12N·m(8.856Lbf.ft)

CAUTION

Securely tighten the locknut after completing adjustment.

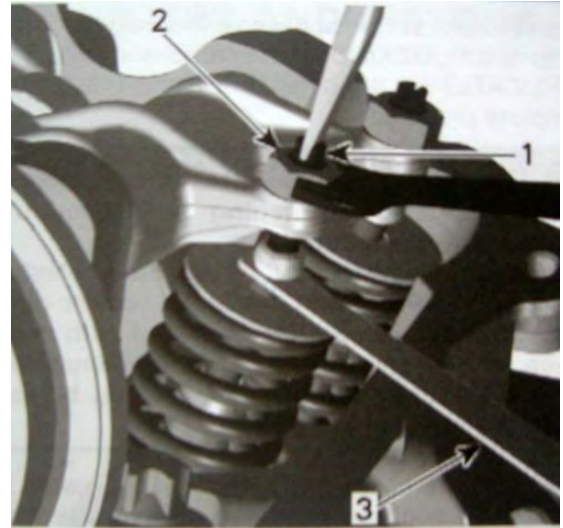

Install the valve cover of both cylinders, spark plug cable and spark plug of both cylinders, the plug screw and O-ring of magneto cover and the crankshaft position sensor.

SPARK PLUG

In case of serious wear or burn to electrode or burn to insulator by spark plug or damage to thread etc, please replace it with new spark plug

In case of carbon deposit, please use proper tools for cleaning.

Spark plug gap

Use clearance gauge to measure clearance of spark plug.

In case of exceeding designated range, then adjust the gap.

Spark plug gap: 0.7-0.9mm
(0.028-0.035inches)

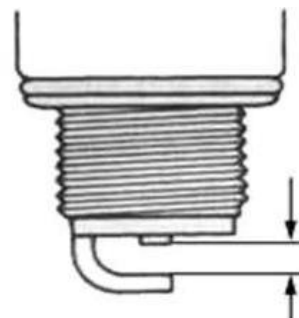

Spark plug heat range

Check the spark plug heat range by observing the electrode color. If the electrode of the spark plug is appearing wet or dark color, replace the spark plug with a hotter type one. If it is white or appearing glazed, replace the spark plug with a colder type one.

Standard type: DCPR8E / NGK

Colder type: DCPR9E / NGK

Hotter type: DCPR7E / NGK

CAUTION

In order to avoid damaging cylinder cap thread, firstly use hands to tighten spark plug and then use spark plug wrench to tighten cylinder cap with designated torque.

THROTTLE CABLE PLAY

Before starting the engine, check the gas pedal to be sure it is operating correctly. Make sure the gas pedal fully returns to the idle position as soon as it is released.

Check the free play and adjust if needed. Press the throttle to make sure it moves smoothly without sticking and snaps back automatically when it is released. Check to see that the gas pedal operates correctly. It must operate smoothly and fully spring back to the idle position when released. Have a dealer repair if necessary for proper operation.

Check throttle pedal free play:

3 - 5mm(0.118-0.197inches)

In case of out of range: → adjustment

Remove left and right seats, gear shift handle and engine shield.



Loose throttle cable (bracing cable).

Turn adjuster to adjust free play of throttle pedal.
After adjustment, tighten nut.

If free play after adjustment cannot reach designated requirement or there is viscosity for throttle valve, replace it with new throttle cable.

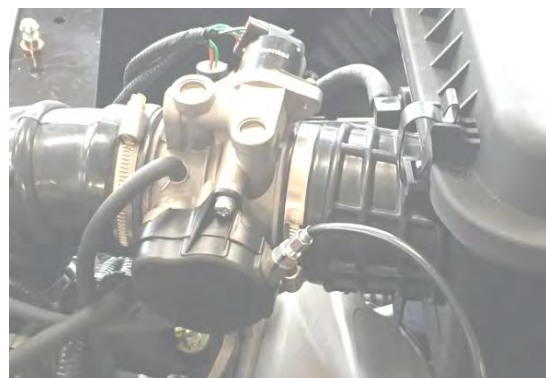

ENGINE OIL

Oil level verification

Strictly follow this procedure, otherwise wrong oil level may be indicated.

1. Ensure vehicle is on a level surface.
2. Start engine and let idle for a few minutes.
3. Stop engine. Wait a few minutes to allow oil to flow down to crankcase then check oil level.
4. Remove passenger side seat.
5. Remove the inspection cover on the engine shield.
6. Remove dipstick and wipe clean stem.
7. Fully screw in dipstick to check oil level.
8. Remove dipstick and read oil level. Oil level must be between minimum(2) and maximum(1) marks on dipstick.
9. There is a capacity of 300 ml between the two marks. Refill oil as necessary. Do not overfill.
10. Re-install dipstick.



Replace engine oil

Prior to change the oil, ensure vehicle is on a level surface. Oil and oil filter must be replaced at the same time. Oil change and oil filter replacement should be done with a warm engine.

WARNING

The engine oil can be very hot. Wait until engine oil is warm.

CAUTION

Dispose oil and filter as per your local environmental regulations.

1. Ensure vehicle is on a level surface.
2. Start engine and let idle for a few minutes.
3. Stop engine. Wait a few minutes to allow oil to flow down to crankcase then check oil level.
4. Remove left and right seats, gear shift handle.
5. Remove engine shield
6. Remove dipstick.
7. Raise the vehicle, support it securely. Place a drain pan under the engine drain plug area.
8. Clean the drain plug area.
9. Unscrew drain plug then remove dipstick.
 - 1) Drain plug
 - 2) Gasket ring
10. Allow oil to drain completely from crankcase.
11. Clean the magnetic drain plug from metal shavings and residue.
12. Install a new gasket ring on drain plug. Torque drain plug to 20 N.m(14.76Lbf.ft).
13. Remove oil filter screws, oil filter cover and oil filter.
 - 1) Oil filter screw
 - 2) Oil filter cover
 - 3) ring
 - 4) Oil filter
14. Check and clean the oil filter inlet area for dirt and other contamination.
15. The installation is the reverse of the removal procedure. Pay attention to install a new gasket on oil filter cover.
16. Refill engine with a SAE 10W-40 API SJ classification engine oil, Oil change capacity with filter 2000mL.
17. Check the oil level with the dipstick. Refer to OIL LEVEL VERIFICATION above.
18. Run engine to ensure oil filter and drain plug areas are not leaking.

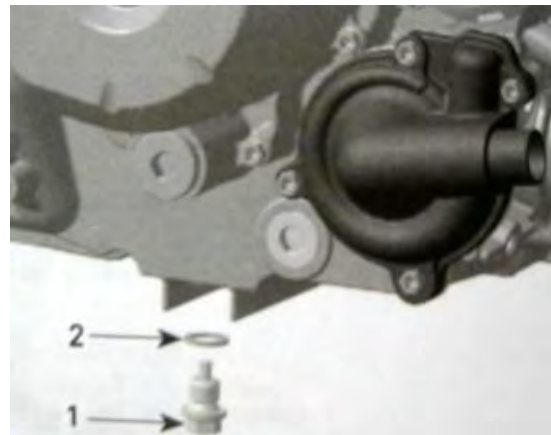

Temp.	°C	-30	-20	-10	0	10	20	30	40
	°F	-22	-4	14	32	50	68	86	104

Viscosity	20W-50	→
	15W-40, 15W-50	→
	10W-40, 10W-50	→
	10W-30	→
	5W-30	→

CAUTION

In order to expand service life of vehicle, please use grade SJ standard engine oil conforming to API with its viscosity indication being SAE10W/40. If viscosity of engine does not reach SAE 10W/40, make corresponding selection according to drawing.

Replace gearbox oil

Prior to change the gearbox oil, ensure vehicle is on a level surface, should be done with a warm engine.

1. Drive vehicle for a few minutes.
2. Ensure vehicle is on a level surface.
3. Stop engine and wait a few minutes.
4. Remove left and right seats, gear shift handle.
5. Remove engine shield
6. Remove the oil level check plug.
7. Place an oil pan under the gearbox case, and then drain oil completely by removing the drain plug.
8. Tighten the drain plug to 20 N.m(14.76Lbf.It).
9. Pour the specified oil(GL-4-90) about 360~450mL by syringe through the oil level check plug hole until the oil over flows.
10. Tighten the oil level check plug to 20 N.m(14.76Lbf.It).

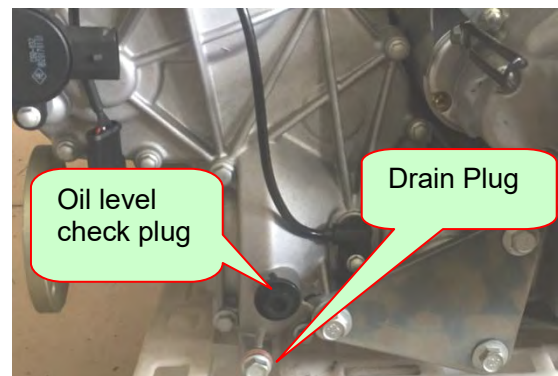
**FRONT DIFFERENTIAL OIL**

To change the front differential oil, locate the vehicle on a level position and carry out the following steps.

Clean the oil level check plug area and remove the oil level check plug.

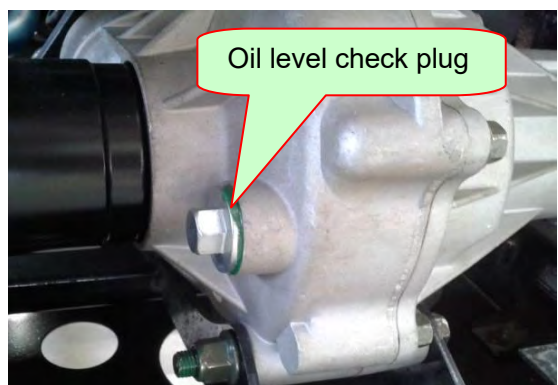

Clean the drain plug area.

Place an oil pan under the front reducer case, and then drain oil completely by removing the drain plug.

Tighten the drain plug to 20 N.m(14.76Lbf.It).

Pour the specified oil(GL-4-90) about 150~180mL by syringe through the oil level check plug hole until the oil over flows.

Tighten the oil level check plug to 20 N.m(14.76Lbf.It).

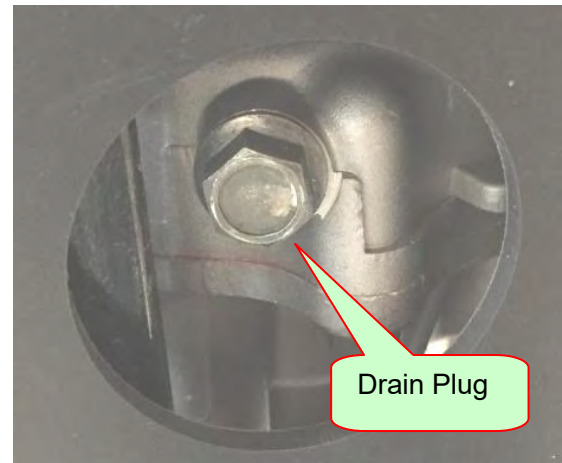

REAR DIFFERENTIAL OIL

To change the rear differential oil, locate the vehicle on a level position and carry out the following steps.

Clean the oil level check plug area and remove the oil level check plug.



Clean the drain plug area.

Place an oil pan under the front reducer case, and then drain oil completely by removing the drain plug.

Tighten the drain plug to 20 N·m(14.76Lbf.It).

Pour the specified oil(GL-4-90) about 500~600mL by syringe through the oil level check plug hole until the oil over flows.

Tighten the oil level check plug to 20 N·m(14.76Lbf.It).

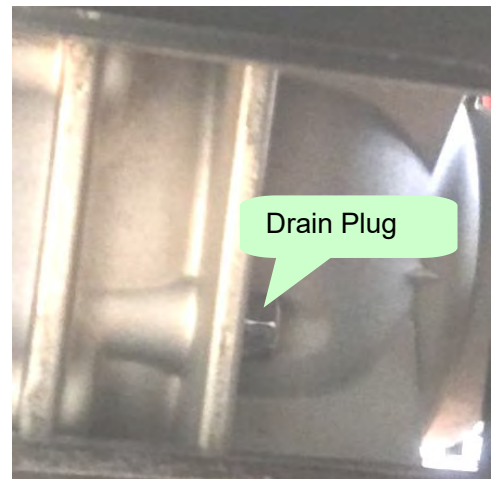

STEERING SYSTEM

Park vehicle at flat ground and hold steering wheel for wobbling to up, down, left and right. Check whether there is loosing. In case of wobbling, tighten nut or dismantle steering column for further inspection.

Park vehicle at flat ground and turn steering wheel left or right slowly to see whether it can be turned flexibly. In case of obstacles, check whether it is caused by main cable or other wiring installation. If it is not caused by above situations, please check the bottom of steering tie rod and see whether steering column bearing is damaged or not.

Park vehicle on flat ground, make sure the tire pressure for right and left tires is same and set to the proper specification, set the front wheels in the straight position, then place a load of 75kg on the seat.



Measure the distance A and B of the front wheels and calculate the difference.

Toe-in.: $B - A = 5\text{mm}(0.197\text{inches})$

A: front of front wheel

B: rear of front wheel

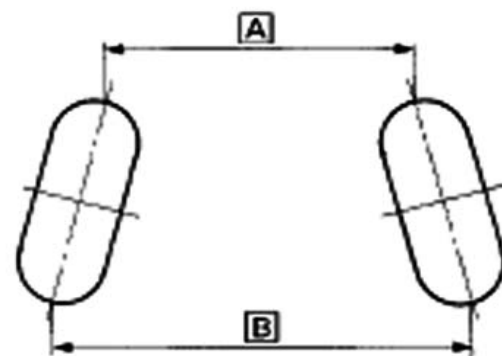

Out of range of toe-in: →Adjust nut of tie rod

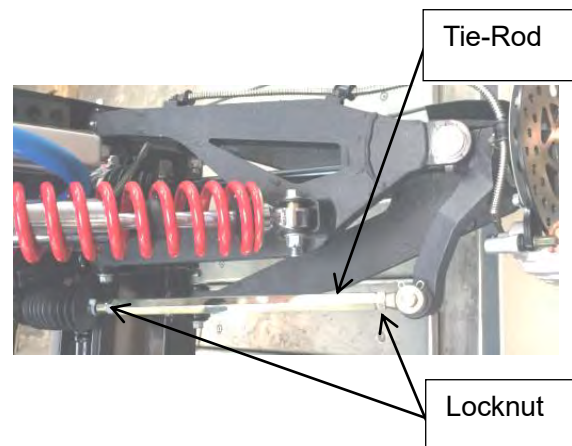

CAUTION

After adjusting toe-in, fist rotate steering wheel from center position to the left and right completely, to ensure that is the same corner, then slowly run vehicle to see whether its direction can be controlled.

BRAKING SYSTEM

Check to see if any brake fluid is leaking out of the pipe joints or the brake fluid reservoir. Apply the brakes firmly for one minute. If there is any leakage, have the vehicle inspected by an authorized dealer.

Test the brakes at slow speed after starting out to make sure they are working properly. If the brakes do not provide proper braking performance, inspect the brake system. If needed, have the vehicle inspected by an authorized dealer.

Brake fluid level

Check the brake fluid level by observing the lower limit line on the brake fluid reservoir.

When the brake fluid level is below the lower edge, replenish with brake fluid DOT4.



Brake pedal adjustment

The brake pedal stroke is 30~40mm(1.18~1.57inches). If less than equal 30mm, it will be a hidden dangers, must adjust the brake pin connecting the brake pedal.



Parking brake adjustment

Pull the parking brake lever up to engage the parking brake. To release the unit, press button on front end of parking lever then push the parking lever to the bottom.

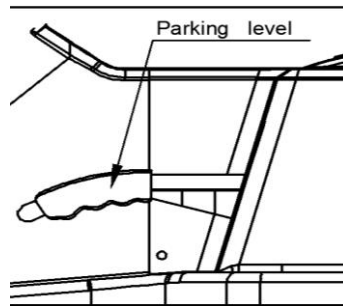

The free play is 15~20mm (0.59~0.79inches), the travel is 7 teeth.

Adjustment nut

If necessary, slacken the cable by loosening the locknut and screwing the adjuster on the brake holder. After adjusting the play, tighten the locknut. Or screwing the adjustment nut on the parking brake caliper

Parking brake caliper

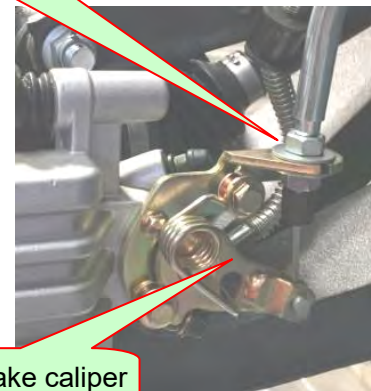

GEAR SHIFT

Check the shift lever as to change gearshift from P to R N H L and reverse smoothly. Also the meter display is correct.

The shift lever should be vertical when the gear is in neutral. If not, adjust the shift cable and then tighten the nuts of the shift cable.



COOLING SYSTEM

To prevent rust formation or freezing condition, always replenish the system with the premixed coolant or with 50% antifreeze and 50% water. Do not use tap water, straight antifreeze or straight water in the system. Tap water contains minerals and impurities which build up in the system. During cold weather, straight water causes the system to freeze while straight antifreeze thickens and does not have the same efficiency. Always use ethylene glycol antifreeze containing corrosion inhibitors specifically recommended for aluminum engines.

Cooling liquid may be reduced by natural evaporation. Regularly check horizontal position of cooling liquid

Coolant level verification

Park vehicle at flat ground, lift the front hood and then check horizontal line of cooling liquid.

Check the level of cooling water in fluid reservoir (auxiliary radiator) is between upper and lower critical levels.



CAUTION

To avoid potential burns, do not remove the radiator cap or loosen the cooling drain plug if the engine is hot. Never drain or refill cooling system when engine is hot.

Coolant replacement

Park vehicle at flat ground and lift the front hood.

Remove the radiator cap.



Partially unscrew coolant drain plug located below water pump housing.

When coolant is drained completely, remove cooling drain plug completely and install a new gasket ring.

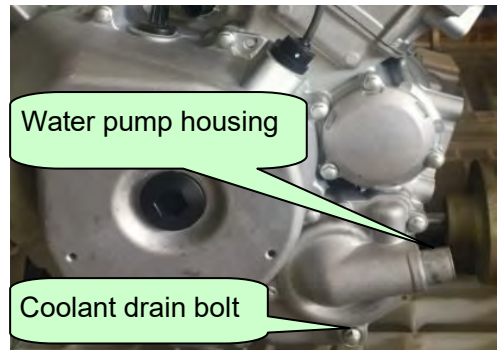

Screw the coolant drain bolt and torque it to 10 N.m(7.38Lbf.It).

Unscrew bleed screws on top of thermostat housing.Both cylinders must be bled.

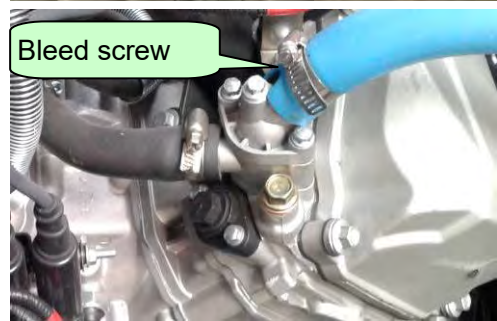

Unscrew bleed bolt on top of radiator.

Fill up the radiator with coolant, when the coolant comes out by the thermostat housing hole, install the bleed screws with its gasket ring and torque to 10 N.m (7.38Lbf.It).



Start the engine and let idle.

Refill coolant to radiator, when the coolant comes out by the radiator bleed hole, install the bleed bolt with its gasket ring and torque to 10 N.m(7.38Lbf.It).

Press and relax the throttle pedal five times to bleed air bubbles completely.

Refill coolant to radiator, and install the the radiator cap.

Run engine until radiator fan opens.

Stop the engine. When engine has completely cooled down, recheck coolant level in the coolant tank, Top up if necessary.

WHEELS

Lift wheels up at horizontal position and ensure no load to each wheel.

Shake wheels to left and right to see whether their connecting parts are installed tightly and check whether they can be swung.

No adequate tightening: → tightening

Swing: → replace rocker arm



Tire pressure

Improper tire pressure will lower comfort of operation and driving and may lead to wear to side edges of tires.

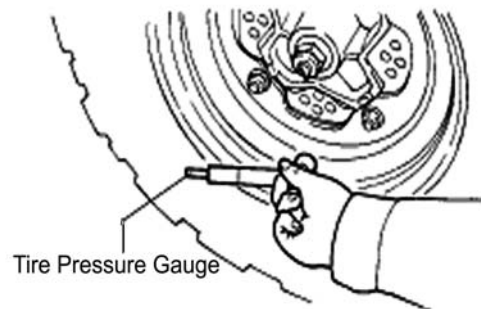

Tire thread.

When the tire groove decreases to 6 mm (0.24 in) due to wear, replace the tire.

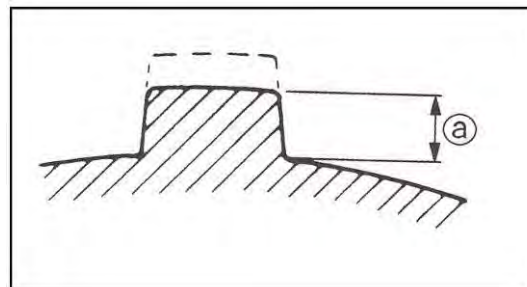

ENGINE COMPRESSION PRESSURE

The compression pressure reading of a cylinder is a good indicator of its internal condition. The decision to overhaul the cylinder is often based on results of a compression test.

Before measuring cylinder pressure, ensure installation and tightening of cylinder cap bolt with designated torque and reasonable clearance of valve.

Standard cylinder pressure: 0.9~1.2Mpa(130.5PSI~174PSI)

Too low cylinder pressure may cause the following:

- Excessive wear to cylinder;
- Wear to piston or piston ring;
- Blockage of piston ring in groove;
- Close valve seat;
- Damage to cylinder lining or faults of other parts

Measure engine compression pressure:

1. Warm up engine.
2. Ensure full charging of battery.
3. Remove left and right seats, gear shift handle and engine shield
4. Dismantle spark plugs.
5. At spark plug hole, install cylinder pressure meter.
6. Press button of start for several seconds. Record indication of maximum cylinder pressure.

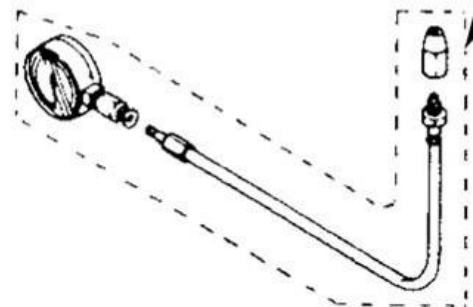

ENGINE OIL PRESSURE

Check the engine oil pressure periodically. This will give a good indication of the condition of the moving parts. The engine oil pressure test should be done with a warm engine and the recommended oil.

Remove left and right seats, gear shift handle and engine shield.



Remove the oil pressure switch wire connector and switch on the right of engine.



Install oil pressure gauge and adapter hose. Start engine on idle speed. The engine oil pressure should be within the following values.

Oil pressure	1250 RPM	6000 RPM
Minimal	70kPa (10.2PSI)	300kPa (43.5PSI)
Nominal	150kPa (21.8PSI)	350kPa (50.8PSI)
Maximal	250kPa (36.3PSI)	450kPa (65.3PSI)

Remove oil pressure gauge and adapter hose.

Installation oil pressure switch to 12 N.m(8.86Lbf.ft) and the oil pressure switch wire connector.

Install engine shield, gear shift handle globe, left and right seats.



SUSPENSION SYSTEM

Lubricate both suspension arms with lithium-soap based grease. There are two grease fittings on each suspension arm. Check operation and for leakage.

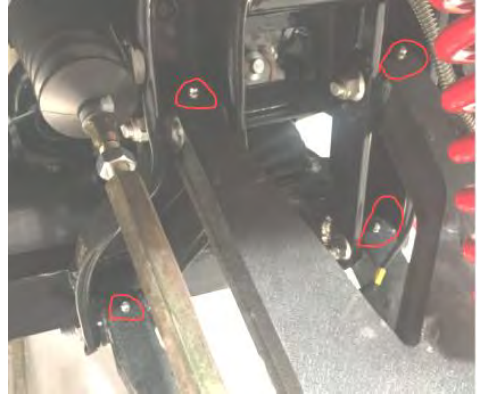

Lubricate rear knuckles with lithium-soap based grease.
There are two grease fittings on each rear knuckle.

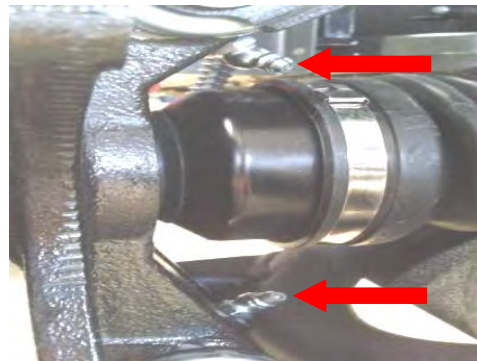

3. ENGINE

ENGINE REMOVAL.....3-2	LUBRICATION SYSTEM.....3-8
MAGNETO SYSTEM3-17	INTAKE MANIFOLD.....3-25
CAMSHAFT.....3-28	VALVE SPRINGS.....3-33
TIMING CHAIN.....3-45	ENGINE DRIVE SHAFT.....3-47
TRANSMISSION (CVT)3-68	ENGINE INSTALLATION.....3-89

Components which are identical for both cylinders/cylinder heads are identified in the two exploded views by the same number. Components which are different or which are, for instance, present on one of the cylinders/cylinder heads but not on the other, have different numbers. The information given below always relates as a general rule.

Special reference is made in the text to work instructions which are not the same for cylinder 1 and 2.



WARNING

Torque wrench tightening specifications must strictly be adhered to.

Locking devices (e.g.: locking tabs, elastic stop nuts, self-locking fasteners, cotter pin, etc.) must be installed or replaced with new ones where specified. If the efficiency of a locking device is impaired, it must be repaired.

1. Cylinder 1 (Front cylinder)
2. Cylinder 2 (Rear cylinder)

When diagnosing an engine problem, always perform a cylinder leak test. This will help pin-point a problem. .

Always place the vehicle on level surface when diagnosing an engine problem.

NOTE: For a better understanding, the many illustrations are taken with engine out of vehicle. To perform the following instructions, it is not necessary to remove engine from vehicle.

Always disconnect BLACK (-) cable from the battery first, then RED (+) cable before working on the engine.

Even if the removal of many parts is not necessary to reach another part, it is recommended to remove these parts in order to check them.

When disassembling parts that are duplicated in the engine, (e.g.: valves), it is a strongly recommended to note their position (PTO/MAG side, front/rear cylinder) and keep them as a "group". If you find a defective component, it would be much easier to find the cause of the failure among its group of parts (e.g.: you found a worn valve guide. A bent spring could be the cause and it will be easy to know which one among the springs is the cause to replace it if you grouped them at disassembly). Also, since used parts have matched together during the engine operation, they will keep their matched fit when you reassemble them together within their "group".

ENGINE REMOVAL

To avoid potential burns, let engine and exhaust system cool down before performing any servicing.

Place vehicle on a work station that will have access to an engine-lifting hoist. Then start with initial preparation.

Disconnect the BLACK(-) cable from battery, then the RED(+) cable.

Drain coolant from engine cooling system. Drain engine oil only if engine overhaul is necessary.

To work on gearbox the removal is necessary but do not drain engine oil.

Remove the left and right footrests.



Refer to CHASSIS.



Unplug the breather hose A

Remove the on the air filter.

Loosen the clamp B on the air filter.

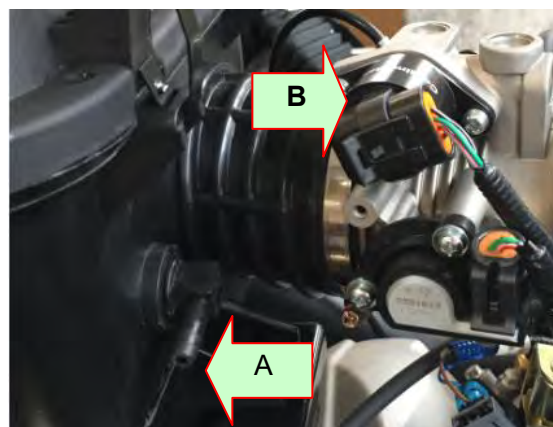

Remove the air filter and mounting bracket.



Unscrew the exhaust clamp securing front the exhaust pipe to "Y" exhaust pipe.



Unscrew the front exhaust pipe nuts.
Unplug the connector of oxygen sensor
Move the front exhaust pipe forward then remove it.

Unscrew the "Y" exhaust pipe nuts from rear cylinder.
Unplug the connector of oxygen sensor
Remove the "Y" exhaust pipe and put it as shown.
Remove the engine upper support bracket.

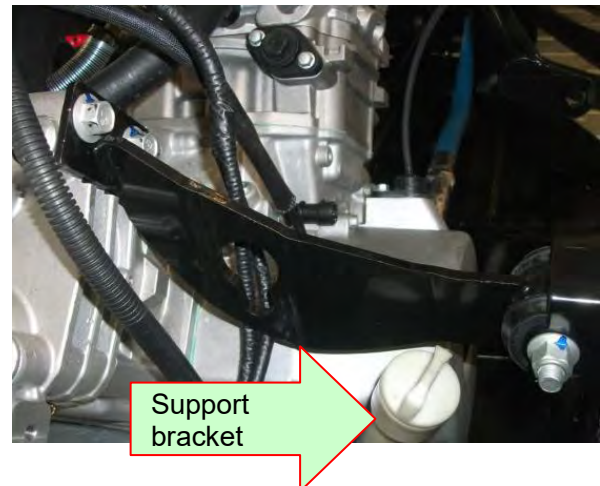

Remove the fuel supply line of front cylinder.
 Remove the fuel supply line of rear cylinder.
 Unplug the fuel injector connectors.
 Unplug the ABV connector A.
 Unplug the TPS connector B.

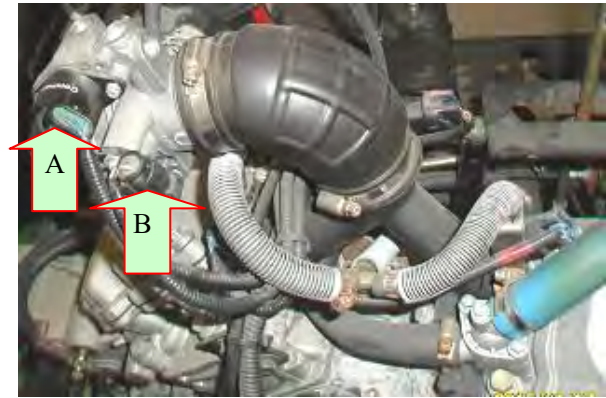

Remove the spark plug cables.
 Remove the ignition coil connector A of rear cylinder.
 Remove the ignition coil connector B of front cylinder.
 Unplug the trigger coil connector C.
 Unplug the magneto connector D.

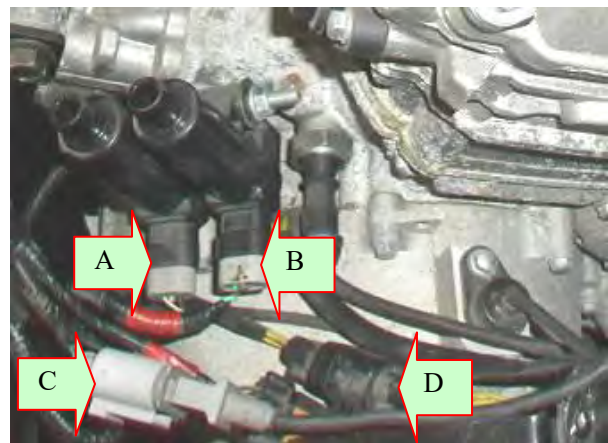

Remove the ignition coils and thin ground wire E.
 Unplug the oil pressure switch wire connector F.

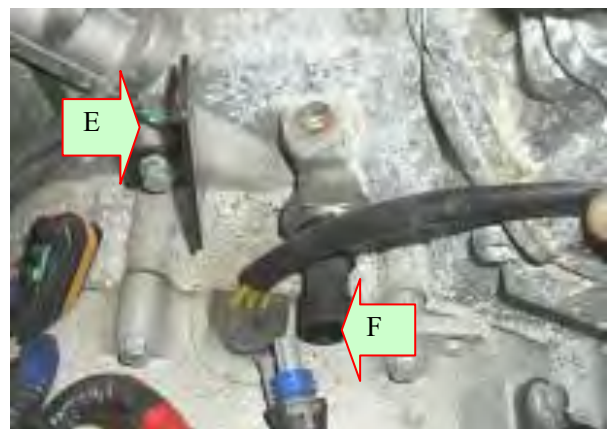

Remove the fat ground wire G.
 Unplug the speed sensor H.

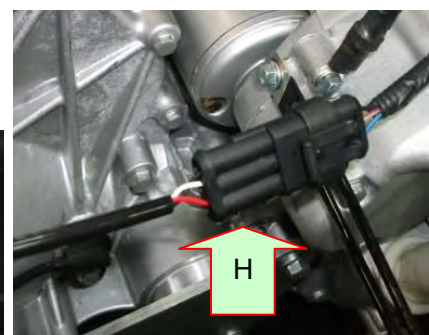
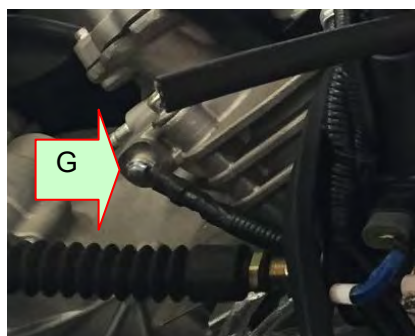

Remove the gear shifting indication wire.



Remove the adiabatic plate of starter motor and the power supply cable K.

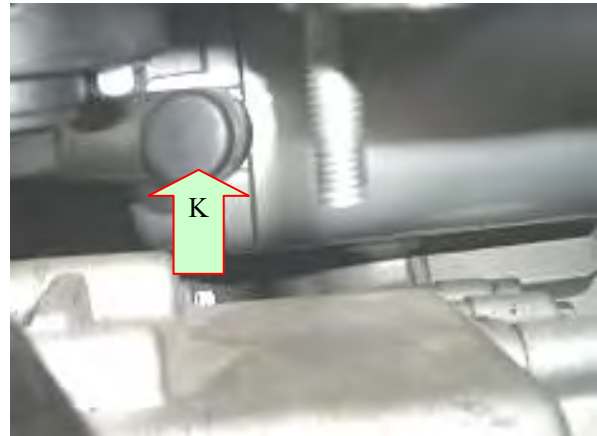

Unscrew the bolt and clamp, remove the CVT inlet and outlet pipes.



Unscrew bolt to remove the shifting plate.



Unplug the intake manifold pressure sensor connector L.
Unplug the coolant temperature sensor connector M.
Remove the throttle cable N.

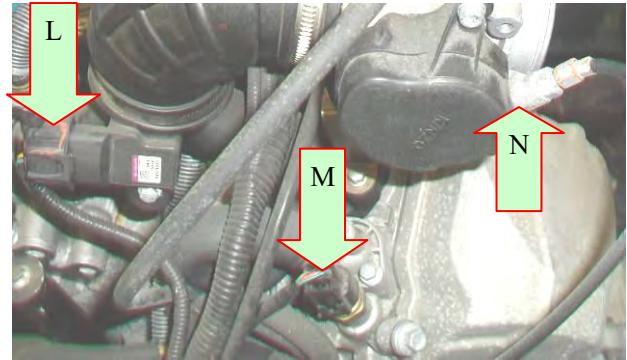

Unscrew the lock nuts to remove the parking brake cable.
Unscrew the mounting bolts to remove the parking brake bracket.



Remove the outlet engine coolant hose.
Remove the inlet engine coolant hose.



Remove the front propeller shaft bolts on engine side.



Remove the rear propeller shaft bolts on engine side.



Remove the rear engine mounting bolt.



Remove the mounting plate of left seat.



Remove the mounting plate of right seat.



Remove the front engine mounting bolt.



Lift the engine to clear mounting brackets
Turn engine 90° front cylinder head toward right side of vehicle.
Remove the engine from vehicle.



LUBRICATION SYSTEM COMPONENTS

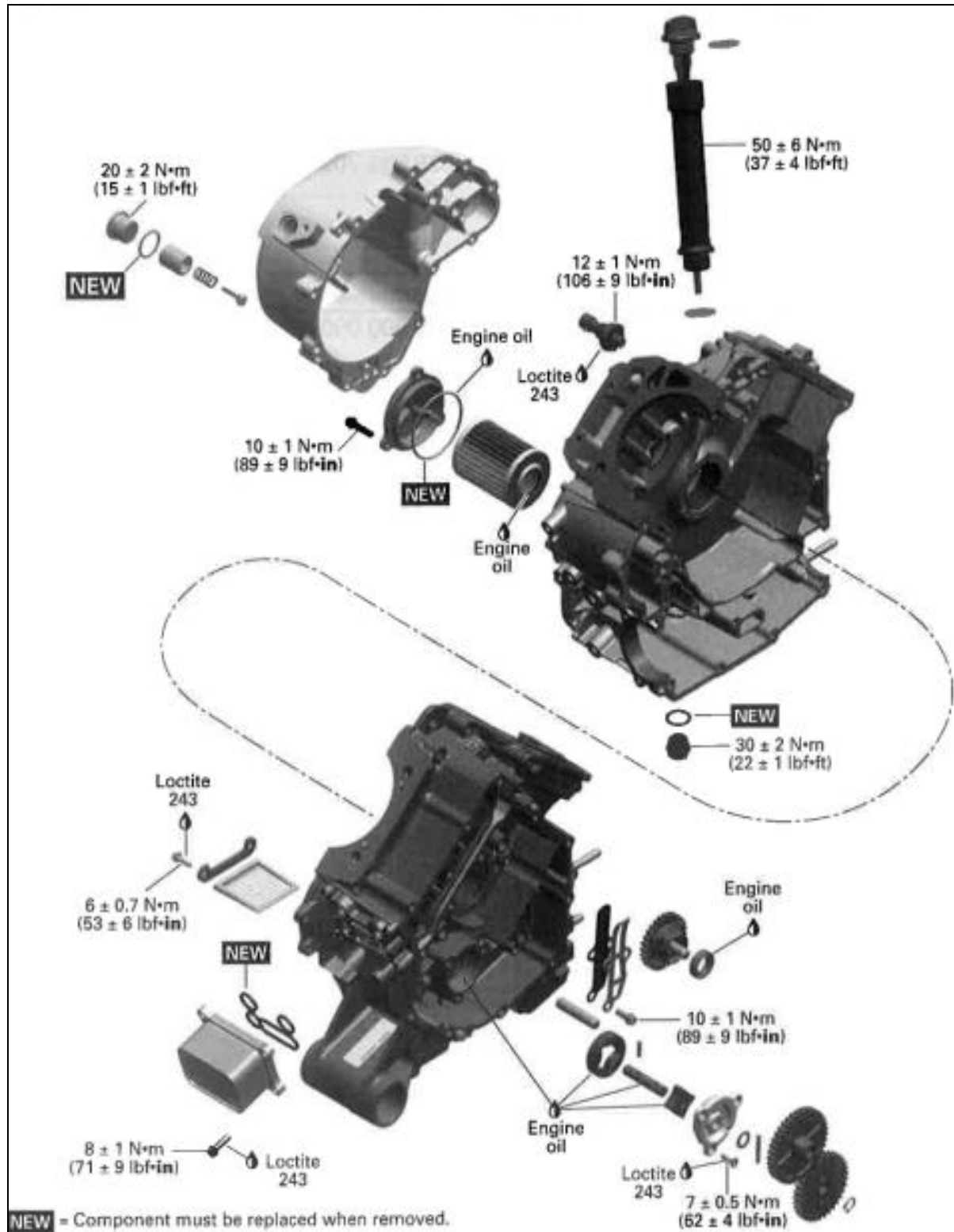

ENGINE LUBRICATION CIRCUIT

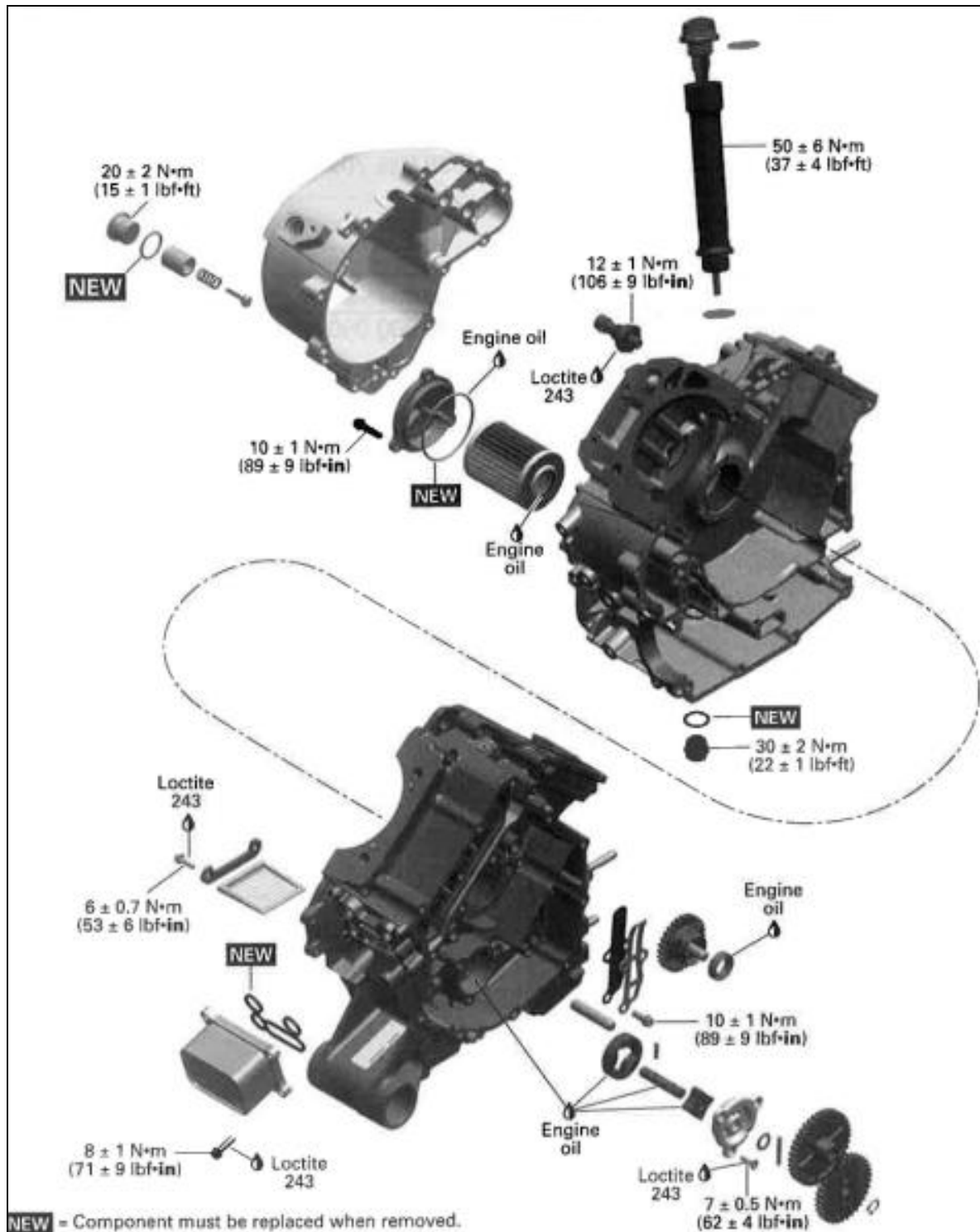

1. Camshaft bearings
2. Oil pressure switch
3. Oil filter
4. Oil pressure regulator valve
5. Oil strainer
6. Oil pump
7. Crankshaft main bearings
8. Crankshaft support bearing
9. Connecting rod' bearings

INSPECTION

ENGINE OIL PRESSURE

NOTE : The engine oil pressure test should be Done with a warm engine 100°C(212°F) and the recommended oil.

Remove the oil pressure switch. Refer to OIL PRESSURE SWICH in this subsection. Use the pressure gauge with the proper adapter hose.

The engine oil pressure should be within the following values.

OIL PRESSURE	1250 RPM	6000 RPM
MINIMAL	70kPa (10PSI)	300kPa (44PSI)
NOMINAL	150kPa (22PSI)	350kPa (51PSI)
MAXIMAL	250kPa (36PSI)	450kPa (65PSI)

If the engine oil pressure is out of specifications,

check the points described in

TROUBLESHOOTING in this subsection.

Remove oil pressure gauge and adapter hose.

NOTE: To remove adapter hose from oil pressure gauge, use the disconnect tool.

Reinstall the oil pressure switch,

TROUBLESHOOTING

LOW OR NO OIL PRESSURE

- Oil level is too low.
 - Refill engine with recommended engine oil
 - Refer to OIL LEVEL VERIFICATION in the PERIODIC MAINTENANCE PROCEDURES subsection.
 - Check for high oil consumption ,refer to HIGH OIL CONSUMPTION in the TROUBLESHOOTING subsection.
 - Check for engine oil leaks. For leak indicator hole, refer to COOLING SYSTEM INSPECTION in the PERIODIC MAINTENANCE PROCEDURES subsection. Repair if necessary.
- Use of unsuitable engine oil type.
 - Replace engine oil by the recommended engine Oil.
- Clogged oil filter.
 - Replace oil and oil filter at the same time.
- Defective oil pressure switch.
 - Test oil pressure switch, see procedure in this subsection.
- Defective or worn oil pump.
 - Check oil pump, see procedure in this subsection.
- Defective engine oil pressure regulator.
 - Check engine oil pressure regulator ,see procedure in this subsection.
- Worn plain bearings in crankcase.
 - Check plain bearings clearance, refer to BOTTOM subsection.
- Clogged engine oil strainer.
 - Check engine oil strainer, see procedure in this subsection.

OIL CONTAMINATION

1. Defective water pump seal ring or rotary seal.

- Check for oil or coolant leak from indicator hole near water pump, refer to COOLING SYSTEM INSPECTION in the PERIODIC MAINTENANCE PROCEDURE subsection. Replace seal if necessary.

2. Cylinder head or cylinder base gasket leak

-Retighten cylinder head to specified torque, refer to TOP END subsection .replace gasket if tightening does not solve the problem.

3.Engine internal damage.

-Repair engine.

4.Oil cooler gasket leak.

-Replace oil cooler gasket and change engine oil.

HIGH OIL CONSUMPTION

1. Leaking breather oil seal.

-Check if the oil seal of the breather is brittle, hard or damaged. Refer to BOTTOM END subsection.

2. Valve stem seals worn or damaged.

-Replace valve stem seals.

3. Worn piston rings(blue exhaust smoke).

-Replace piston rings.

PROCEDURES

OIL COOLER

Oil Cooler Access

Refer to BODY and remove:

- Upper console
- Lower console
- RH lateral console panel
- RH inner panel
- Fuel tank cowl.

Oil Cooler Removal

Refer to the PERIODIC MAINTENANCE PROCEDURES subsection to:

- Drain engine oil.

- Drain engine coolant.

Remove oil cooler retaining screws.



1 .Retaining screws

2. Oil cooler

Place rags or towels under oil cooler to catch remaining oil and coolant.

Remove oil cooler and discard gasket.



1. Oil cooler

2. Gasket

Oil Cooler Inspection

Check oil cooler for cracks or other damage.

Replace if necessary.

Oil Cooler Installation

For installation, reverse the removal procedure. Pay attention to the following details.

Wipe off any oil and coolant spillage.

Install a NEW gasket.

Refer to PERIODIC MAINTENANCE PROCEDURES subsection and carry out the following:

- Refill engine oil with recommended oil and at the proper oil level.

- Refill and bleed cooling system.

OIL PRESSURE SWITCH (OPS)

Oil Pressure Switch Location

The oil pressure switch is located at engine MAG side above the magneto cover.



1. Oil pressure switch

Oil Pressure Switch Access

Refer to BODY and remove:

- Upper console
- Lower console
- RH lateral console panel
- RH inner panel
- Fuel tank cowl.

Oil Pressure Switch Activation

The oil pressure switch activates when the engine oil pressure is lower than the operating pressure.

OIL PRESSURE SWITCH OPERATING PRESSURE
30kpa ±10kap (4.35PSI ±1.45 PSI)

To check the function of the oil pressure switch, an oil pressure test has to be performed. Refer to ENGINE OIL PRESSURE in this subsection.

If the engine oil pressure is good perform the oil pressure switch resistance test.

Oil Pressure Switch Resistance Test

Disconnect the connector from the oil pressure switch.

Use a multimeter to check the resistance between as shown.

OPS CONNECTOR		ENGINE NOT RUNNING	ENGINE RUNNING
PIN		RESISTANCE(Ω)	
4	Engine ground	Close to 0Ω (normally reaches	Infinite(open) when pressure 30kPa±10kPa (4.35PSI±1.45PSI)

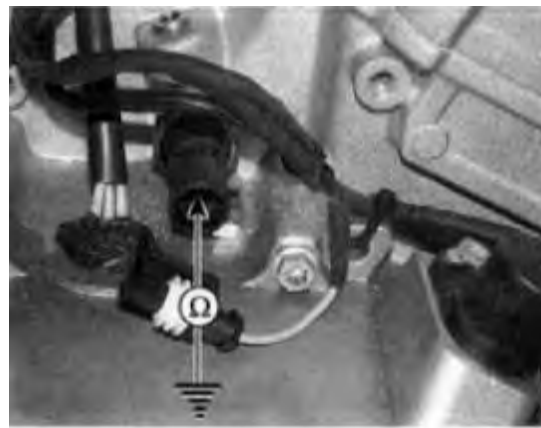

If resistance values are incorrect, replace the oil pressure switch.

If the values are correct, check wiring.

Oil Pressure Switch Removal

Unplug the oil pressure switch connector. Unscrew and remove oil pressure switch.

Oil Pressure Switch Installation

Tighten oil pressure switch to specified torque.

OIL PRESSURE SWITCH	
Service product	LOCTITE243
Tightening torque	12N·m±1 N·m (106lbf·in±9lbf·in)

ENGINE OIL PRESSURE REGULATOR

Oil Pressure Regulator Location

The oil pressure regulator is located on the engine magneto side (inside magneto cover).

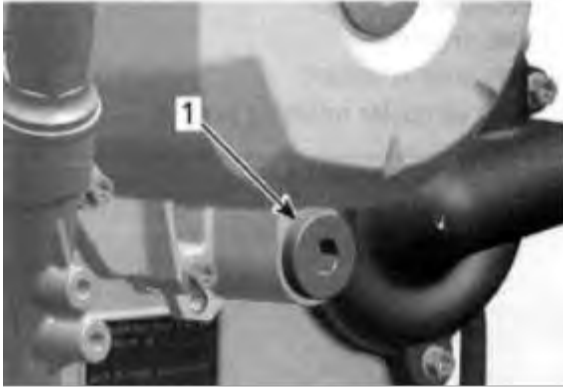

1. Engine oil pressure regulator

NOTE: The oil pressure regulator system works when the oil pressure exceeds 400kPa (58PSI).

Oil Pressure Regulator Access

Refer to BODY and remove:

- Upper console
- Lower console
- RH lateral console panel
- RH inner panel
- Fuel tank cowl.

Oil Pressure Regulator Removal

Remove plug screw and pull oil pressure regulator out.

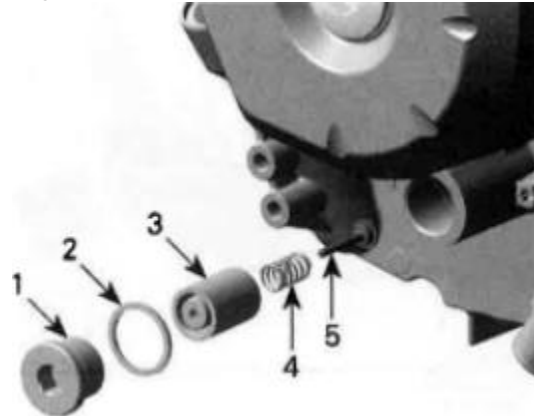

1. Plug screw
2. Gasket ring
3. Pressure regulator housing
4. Spring
5. Pressure regulator valve

Oil Pressure Regulator Inspection

Inspect pressure regulator housing and valve for scoring or other damages. Check spring for free length.

SPRING FREE LENGTH	
NEW NOMINAL	39mm(1.535in)
SERVICE LIMIT	37 mm(1.457in)

NOTE: Replace worn or damaged components.

Clean bore and thread in the magneto housing from metal shavings and other contamination.

Oil Pressure Regulator Installation

For installation, reverse the removal procedure.

Pay attention to the following details.

NOTE: At installation always replace the gasket ring of the plug screw by a new one.

OIL PUMP

Oil Pump Location

The oil pump is located on the engine PT0 side (behind PT0 cover).

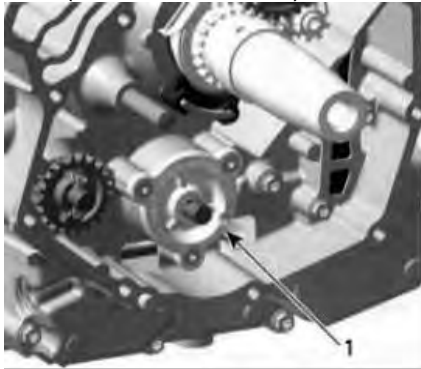

1. Oil pump

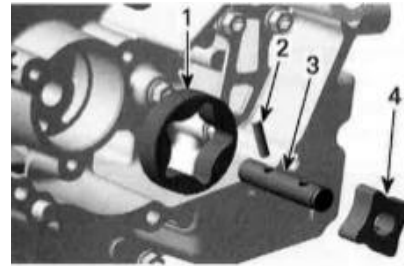

1. Outer rotor
2. Needle pin
3. Oil pump shaft
4. Inner rotor

Oil Pump Inspection

Inspect oil pump and oil pump cover bore for marks, scratches or other damages. Check for scratches in crankcase between outer rotor and oil pump bore. If so, replace damaged parts.

Check oil pump cover for damages and for surface straightness with a straightedge.

Oil Pump Removal

Remove the PT0 cover. Refer to PTO COVER in the BOTTOM END subsection.

1. Remove:

- Retaining ring
- _ Oil pump gear
- Needle pin
- Thrust washer.



1. Thrust washer 2. Needle pin
3. Oil pump gear 4. Retaining ring

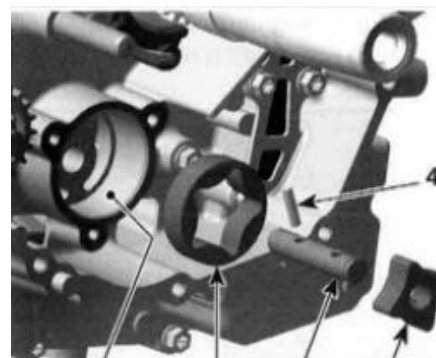

1. Oil pump bore 2. Outer rotor
3. Oil pump shaft 4. Needle pin
5. Inner rotor

2. Remove oil pump cover screws and pull oil pump cover out..

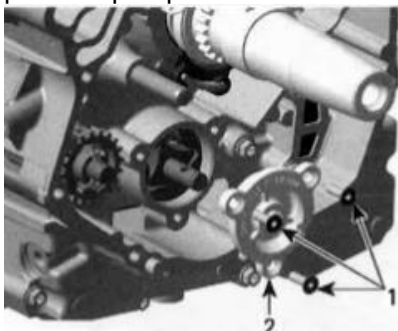

1. Retaining screws 2. Oil pump cover
3. Remove oil pump shaft with needle pin and inner rotor.
4. Remove outer rotor.

Check inner rotor for corrosion pin holes or other damages. If so, replace oil pump shaft assembly.



1. Pitting on the teeth

Using a feeler gauge, measure the clearance of inner and outer rotors as shown.

CLEARANCE OF INNER AND OUTER ROTOR	
SERVICE LIMIT	0.25mm (.0098in)

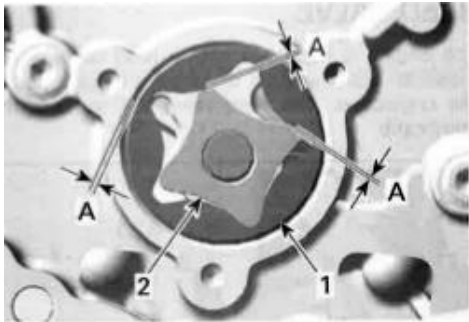

- 1. Outer rotor
- 2. Inner rotor
- A. 0.25mm (.0098in)

If clearance of inner and outer rotors exceeds the Tolerance, replace oil pump rotors. Ensure to also check oil pump cover. If damaged, replace the complete oil pump assembly.

If clearance between outer rotor and its bore in crankcase exceeds the tolerance, replace the complete oil pump rotors and/or the crankcase.

Using a depth gauge, measure the axial clearance of the oil pump as shown.

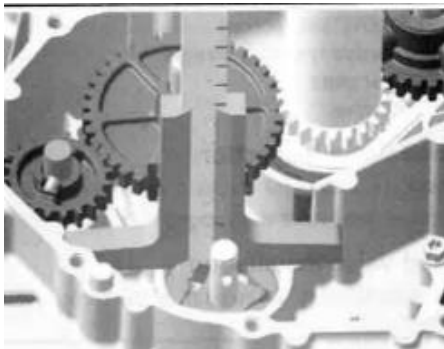

OIL PUMP- MEASUREMENT "A"



OIL PUMP COVER- MEASUREMENT "B"

Subtract measurement "B" from measurement "A" to obtain axial clearance.

OIL PUMP AXIAL CLEARANCE	
SERVICE LIMIT	0.2 mm(.0079in)

NOTE: When the axial clearance of the oil pump shaft assembly increases, the oil pressure decreases.

Oil Pump Installation

For installation, reverse the removal procedure.

Pay attention to the following details.

NOTE: When installing the oil pump rotors, make sure both markings are on the outer side.

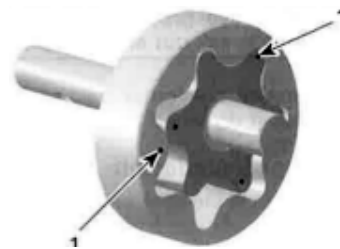

TYPICAL

- 1. Markings

After re-installation of the remaining parts, check for smooth operation of the oil pump assembly.

Oil Pump Final Test

After engine is completely reassembled, start engine and make sure oil pressure is within specifications (refer to ENGINE OIL PRESSURE in this subsection).

ENGINE OIL STRAINER

Oil Strainer Location

The engine oil strainer is located between both crankcase halves.

Oil Strainer Removal

Separate crankcase halves .Refer to BOTTOM END subsection.

Remove screws and retaining plate.

Pull out engine oil strainer.



1. Engine oil strainer
2. Retaining plate
3. Screws

Oil Strainer Cleaning and Inspection

Clean engine oil strainer with a part cleaner then use an air gun to dry it.

▲WARNING

Always wear eye protector. Chemicals can cause a rash break out and injure your eyes.

Check engine oil strainer for cracks or other damage. Replace if damaged.

Oil Strainer Installation

The installation is the reverse of the removal procedure.

OIL STRAINER RETAINING SCREWS	
Service product	LOCTITE243
Tightening torque	6N·m± 0.7N·m (53lbf·in±6lbf·in)

REED VALVE

The engine is equipped with a reed valve which prevents accumulation of larger oil quantities in the crankcase. The reed valve is fitted into the crankcase.

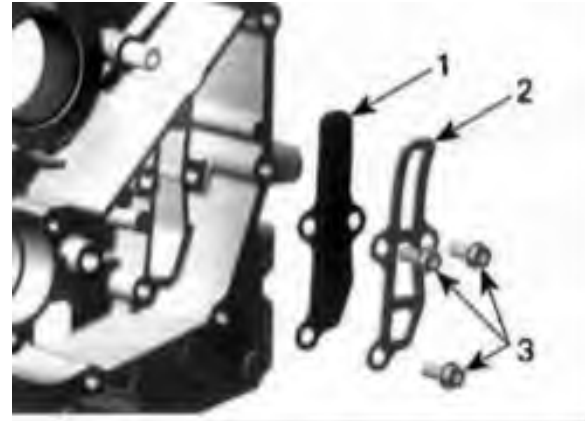

1. Reed valve
2. Stopper
3. Screws

Reed Valve Removal

Remove:

- PTO cover (refer to PTO COVER in the BOTTOM END subsection)
- Reed valve retaining screws
- Stopper plate
- Reed valve.

Reed Valve Inspection

Check reed valve for cracks or other damage.

Replace reed valve if damaged.

Reed Valve Installation

The installation is the reverse of the removal procedure.

REED VALVE RETAINING SCREW	
Tightening torque	10N·m±1N·m (89lbf·in±9lbf·in)

MAGNETO SYSTEM

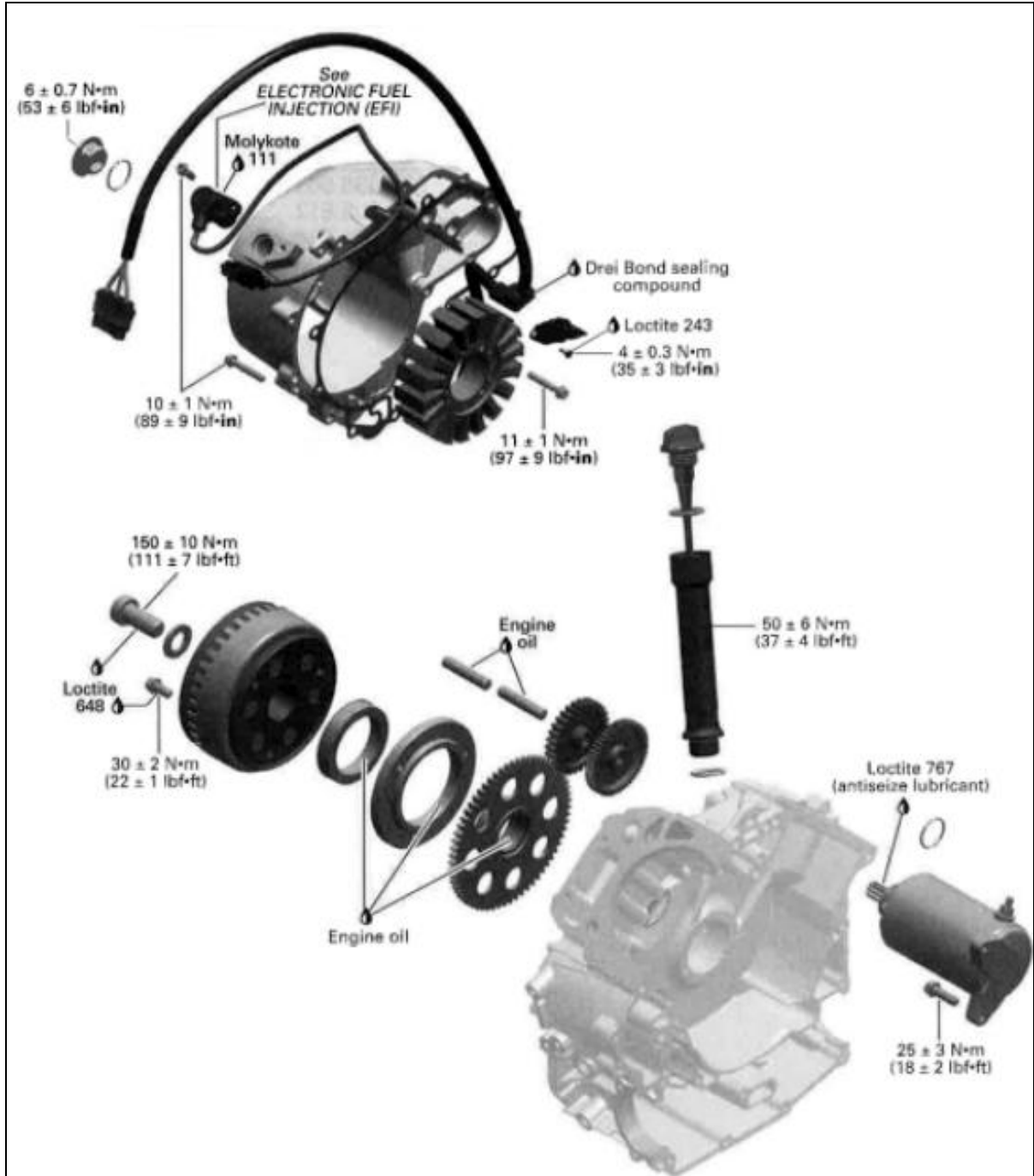

PROCEDURES

MAGNETO COVER

Magneto Cover Access

Remove fuel tank, refer to FUEL TANK AND FUEL PUMP

Magneto Cover Removal

Drain engine oil (refer to PERIODIC MAINTENANCE PROCEDURES subsection).

Remove crankshaft position sensor (CPS) and cut tie raps.

Remove dipstick and oil level tube with O-rings.



1. Dipstick
2. Oil level tube
3. Crank position sensor (CPS)
4. O-rings

Remove magneto cover retaining screws

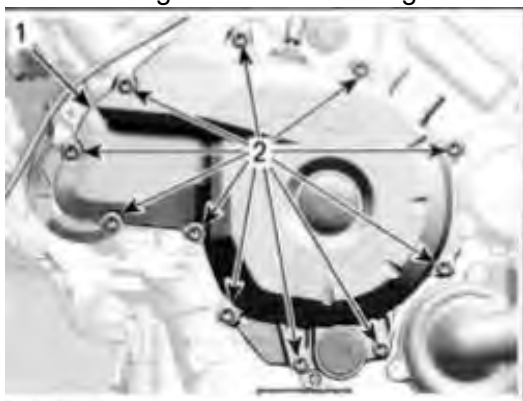

1. Magneto cover
2. Retaining screws

Pull out magneto cover.

NOTE: If required, remove stator and harness from magneto cover.

Magneto Cover Inspection and Cleaning

Check magneto cover for cracks or other damage. Replace if necessary.

NOTE: Clean all metal components in a nonferrous metal cleaner. Use LOCTITE CHISEL (GAS- KET REMOVER) (P/N413 708 500), or suitable equivalent.

▲ WARNING

Wear safety glasses and work in a well ventilated area when working with strong chemical products. Also wear suitable nonabsorbent gloves to protect your hands.

Magneto Cover Installation

For installation, reverse the removal procedure. However, pay attention to the following.

NOTE: Install a NEW magneto cover gasket.

Apply DREI BOND SEALING COMPOUND (P/N420 297 906) on stator cable grommet as shown in next illustration.



1. Stator cable grommet (apply sealing compound)

Tighten screws using the following sequence

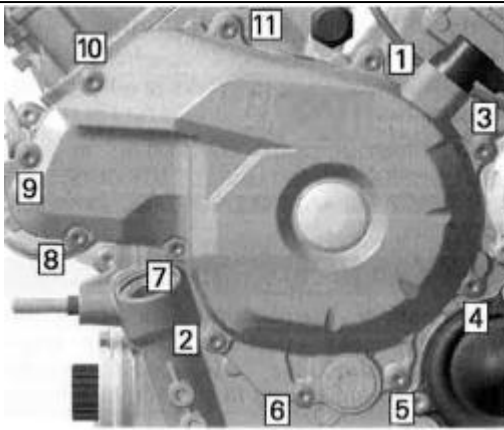

TIGHTENING SEQUENCE

MANGENTO COVER SCREW	
Tightening torque	10N.m±1N.m (89lb.in±9lb.in)

Refill engine with recommended oil.

STATOR

Stator Connector Access

NOTE: The stator is directly connected to the voltage regulator/rectifier.

Stator Static Test: Continuity

1. Disconnect the stator connector from the voltage regulator/rectifier.
2. Check resistance between YELLOW wires.

REQUIED TOOL	
FLUKE115 MULTIMETER	

TERMINAL	RESISTANCE@ 20°C(68°F)
1 and2	0.15 - 0.30Ω
1 and3	
2 and3	

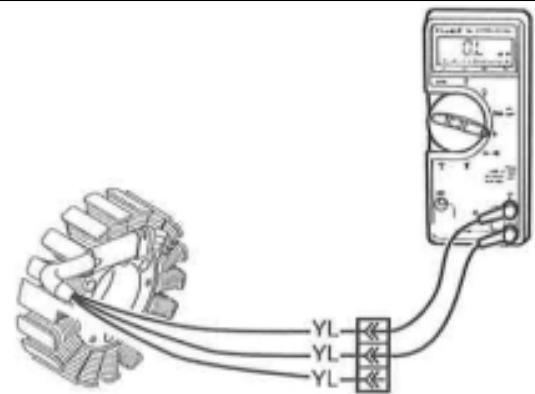

TYPICAL

3. If any reading is out of specification, replace stator.
4. Re-plug connectors properly.

Stator Static Test: Insulation

1. Disconnect the stator connector from the voltage regulator/rectifier.
2. Connect multimeter between any YELLOW wire(on stator connector) and engine ground.

REQUIED TOOL	
FLUKE115 MULTIMETER	

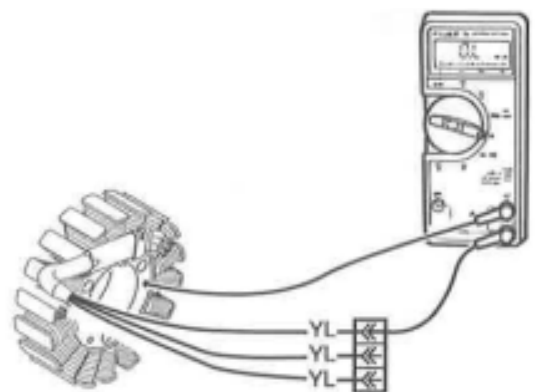

TEST PROBES	RESISTANCE@ 20°C(68°F)
Any YELLOW wire and engine ground	Infinite (open circuit)



3. If there is a resistance or continuity, the stator coils and/or the wiring is shorted to ground and needs to be repaired or replaced.
4. Re-plug connectors properly.

Stator Dynamic Test: AC Voltage Output

1. Disconnect stator connector at voltage regulator/rectifier.
2. Start engine.
3. Check AC voltage output as follow:

REQUIRED TOOL	
BACK PROBE TEST WIRES	
FLUKE 115 MULTIMETER	

4. Read voltage as per following table.

TEST ENGINE SPEED	TERMINAL	VOLTAGE
4000 RPM	1 and 2	15 Vac MINIMUM
	1 and 3	
	2 and 3	

5. If voltage is lower than specification, replace stator.
6. Re-plug connectors properly.

Stator Removal

Remove MAGNETO COVER.

See procedure in this subsection.

Remove screws securing the wire holding strip.

Remove stator retaining screws then the stator.

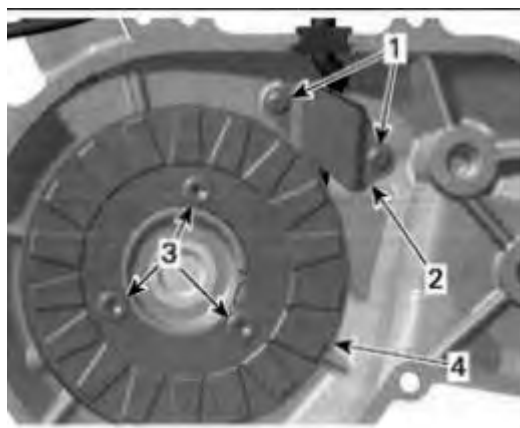

1. Holding strip screws
2. Wire holding strip
3. Stator retaining screws
4. Stator

Stator Inspection

Check stator windings and insulation for cracks or other damages. If damaged replace it.

Check if stator wires are brittle, hard or otherwise damaged.

Stator Installation

For installation, reverse the removal procedure. However, pay attention to the following.

When installing the stator take care to route wires properly and install retaining strip.

NOTE: There is only one position for the stator (notch in the magneto housing cover).

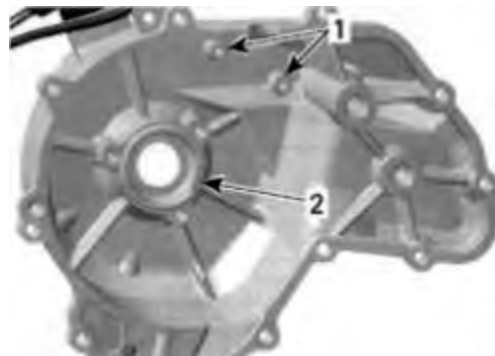

1. Threads for cable holding strip
2. Notch for stator

HOLDING STRIP SCREWS	
Service product	LOCTITE243
Tightening torque	4N·m± 0.5N·m (35lbf·in±4lbf·in)

STATOR RETAINING SCREWS	
Tightening torque	11N·m± 1N·m (97lbf·in±9lbf·in)

HOLDING STRIP SCREWS

Service product
LOCTITE243

Tightening torque
4N·m± 0.5N·m
(35lbf·in±4lbf·in)

ROTOR

Rotor Removal

Remove MAGNETO COVER. See procedure in this subsection.



Lock crankshaft(refer to CRANKSHAFT LOCKING PROCEDURE in the BOTTOM END subsection).

REQUIRED TOOL	
CRANKSHAFT LOCKING BOLT	

Heat screw in order to break the glue.

Remove screw and washer securing rotor to crankshaft.

Remove rotor.

REQUIRED TOOL	
MAGNETO PULLER	
CRANKSHAFT PROTECTOR	

NOTE: Use grease to place protector on crank- shaft end prior to screw on the magneto puller.



1. Rotor
2. Magneto puller

Screw magneto puller bolt to remove rotor.

Rotor Inspection

Check inner side of rotor for scratches or other damage.

Blow pressurized air in the rotor oil bore and make sure it is not clogged.



1. Rotor
2. Oil bore

Check keyway of the rotor for wear or damages. Check if trigger wheel teeth are bent or otherwise damaged.

Check woodruff key and keyway on the crank- shaft for wear or damages.

Replace parts as necessary.

Rotor Installation

For installation, reverse the removal procedure.

However, pay attention to the following.

Use PULLEY FLANGE CLEANER (P/N413 711 809) to clean following:

- Crank shaft taper
- Oil passage in crank shaft taper
- Thread in crankshaft
- Rotor taper
- Oil bore in rotor.

█ Taper on crankshaft and rotor must be free of grease.

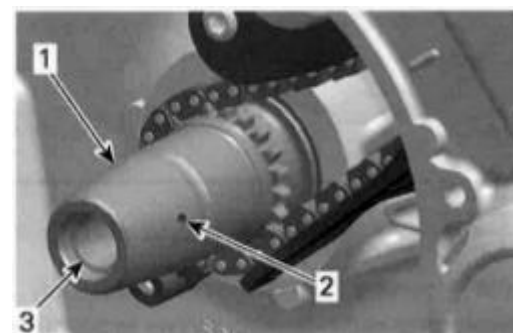

1. Crankshaft (MAG side)
2. Oil passage
3. Threads

Oil sprag clutch and instal1 sprag clutch gear.

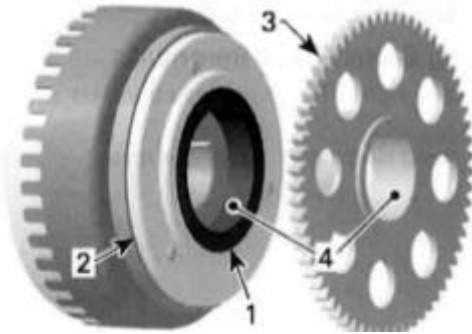

1. Sprag clutch
2. Sprag clutch housing
3. Sprag clutch gear
4. Apply engine oil here

Slide rotor onto crankshaft. The woodruff key and the keyway must be aligned. Rotate starter double gear counterclockwise to align intermediate gear teeth with sprag clutch gear.

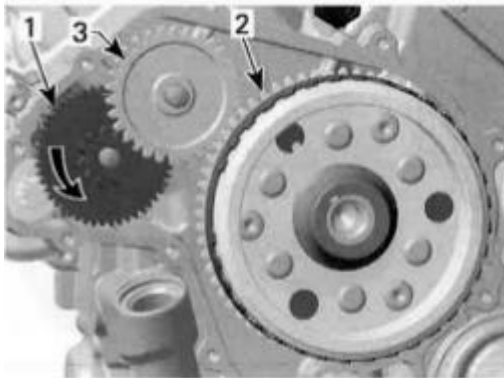

1. Starter double gear
2. Sprag clutch gear
3. Intermediate gear

ROTOR RETAINING SCREW	
Service product	LOCTITE648
Tightening torque	150N·m±10N·m (111 lbf·ft±7lbf·ft)

SPRAG CLUTCH

Sprag Clutch Removal

Remove MAGENTO CIVER.

See procedure in this subsection.

Heat screws in order to break the glue.

Loosen sprag clutch housing screws located inside rotor.



1. Rotor
2. Sprag clutch housing screws

Remove rotor(refer to ROTOR in this subsection).

Remove sprag clutch gear.

Remove sprag clutch housing screws and sprag clutch housing.



1. Sprag clutch housing screws
2. Rotor
3. Sprag clutch
4. Sprag clutch housing

Sprag Clutch Inspection

Inspect sprag clutch and sprag clutch housing for wear and damage.

Also check the collar of the sprag clutch gear.

Rotate sprag clutch gear in sprag clutch.

NOTE: Sprag clutch must lock in counterclockwise direction.



SPRAG CLUTCH FUNCTION TEST

1. Lock

NOTE: Sprag clutch, housing and gear must be replaced at the same time, if damaged.

Sprag Clutch Installation

For installation, reverse the removal procedure.

Pay attention to the following details.

Apply LOCTITE648 (GREEN) (P/N413 711 400) on threads of sprag clutch housing screws.

Install screws but do not torque yet.

Apply engine oil on sprag clutch and sprag clutch gear needle bearing.

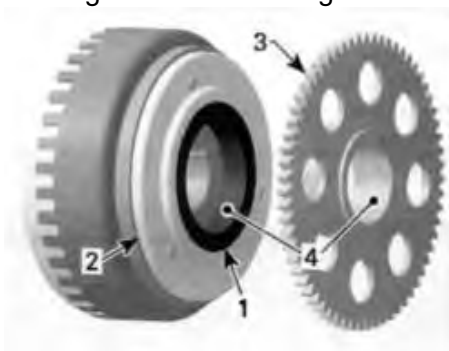

1. Sprag clutch
2. Sprag clutch housing
3. Sprag clutch gear
4. Apply engine oil here

Install rotor, refer to ROTOR in this subsection.

Tighten sprag clutch housing screws to specification.

SPRAG CLUTCH HOUSING SCREW	
Tightening torque	30N·m±2N·m (22 lbf·ft±1lbf·ft)

SPRAG CLUTCH GEAR

Sprag Clutch Gear Removal

Remove ROTOR. See procedure in this subsection.

Pull sprag clutch gear out of the rotor.



1. Rotor
2. Sprag clutch gear

Sprag Clutch Gear Inspection

Inspect gear, especially teeth and sprag clutch Collar, for wear and other damage.

Check needle bearing condition.

Replace sprag clutch gear if necessary.

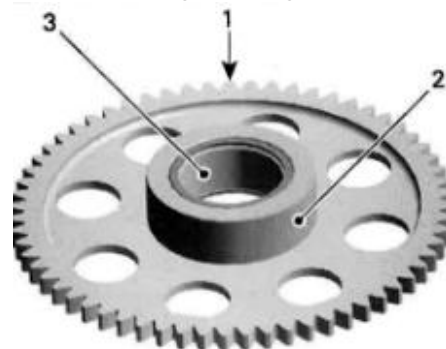

INSPECT

1. Teeth
2. Collar
3. Needle bearing

Sprag Clutch Gear Installation

The installation is the reverse of the removal Procedure.

NOTE: Apply engine oil on needle bearing and Collar of sprag clutch gear.

STARTER DRIVE GEARS

Starter Drive Gear Location

The starter drive gears are located on the engine MAG side behind the magneto cover.

Starter Drive Gear Removal

Remove MAGENTO COVER. See procedure in this subsection.

Remove location pins, starter double gear and intermediate gear.



1. Intermediate gear
2. Starter double gear
3. Starter gear
4. Location pins

Starter Drive Gear Inspection

Inspect gears and location pins for wear and damage.

Replace parts as necessary.

Starter Drive Gear Installation

The installation is the reverse of the removal Procedure. Pay attention to the following details.

Apply LOCTITE 767 (ANTISEIZE LUBRICANT) (p1N2g3 800 o7o) on starter gear before installing the starter double gear. Apply engine oil on location pins.

INTAKE MANIFOLD PROCEDURES

PLENUM BRACKET

Plenum Bracket Installation

On Cylinder1, install the plenum bracket using the appropriate mounting holes.



1. Mounting holes for the 1000 engine
Tighten plenum bracket retaining screws to specification

PLENUM BRACKET RETAINING SCREWS	
Tightening torque	10N·m±1 N·m (89lbf·in±9lbf·in)

INTAKE MANIFOLD

Intake Manifold Access

Refer to BODY and remove the lower console .

Intake Manifold Removal

1. Disable fuel pump using DELPHI. Select the
 - 1.Click “Disable”
 2. Release fuel pressure by running engine until it runs out of gas.
 3. Disconnect the fuel hoses at the fuel injectors , refer to ELECTRON FUEL INJECTION (EFI).

⚠ CAUTION
The fuel hose may still be under pressure.

4. Disconnect fuel injectors electrical connectors .
5. Remove plenum adapter elbow.

6. Remove intake manifold from engine

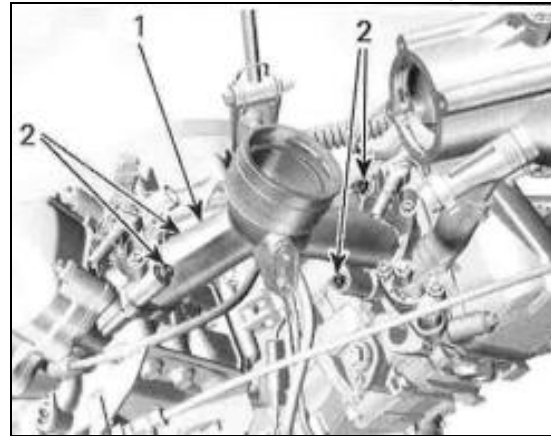

SOME PARTS REMOVED FOR CLARITY

- 1 Intake manifold
2. Remove retaining screws (x4)

Intake Manifold Inspection

Check intake manifold for cracks, warping at flanges or any other damage. Replace if necessary.

Intake Manifold Installation

The installation is the reverse of the removal procedure. However, pay attention to the followin9.

Tighten intake manifold retaining screws to specified torque one cylinder at a time.

INTAKE MANIFOLD RETAINING SCREWS	
Tightening torque	20N·m±2.5N·m (15lbf·ft ± 2 lbf·ft)

Tighten elbow retaining screws to specification.

INTAKE MANIFOLD RETAINING SCREWS	
Tightening torque	10N·m±1N·m (89lbf·ft ± 9 lbf·ft)

Tighten intake manifold clamps to specification.

INTAKE MANIFOLD RETAINING SCREWS	
Tightening torque	0.7N·m±0.1N·m (6lbf·ft ± 1 lbf·ft)

Enable fue1 pump using DELPHI

CAMSHAFT

NOTE: The engine is equipped with two different camshafts.



1. Intake cam
2. Exhaust cam
3. Camshaft of cylinder 1
4. Camshaft of cylinder 2
5. Flat spot

Camshaft Removal

The removal procedure is the same for both camshafts.

Each camshaft is different in design.

Thus, it is important not to mix up any parts of the camshaft assembly with that of the other cylinder. Keep parts as a group.

Remove valve cover(see VALVE COVER in this subsection).

Refer to TIMING CHAIN subsection and remove the following parts:

- Timing chain tensioner
- Camshaft timing gear.

Remove the camshaft retaining plate.



1. Camshaft retaining plate
2. Pan head screw
3. Cylinder head

Remove rocker arms (see ROCKER ARM in this subsection).

Remove the camshaft.

NOTE: For removal rotate camshaft so that intake/ exhaust lobe shows to upper side of cylinder head.



1. Camshaft retaining plate
2. Area for camshaft lobes
3. Camshaft

Camshaft Inspection

Camshaft Lobe Inspection

Check each lobe for scoring, scuffing, cracks or other signs of wear.

Measure camshaft lobe height using a micrometer

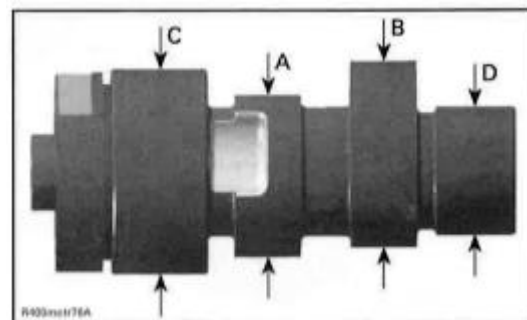

- A. Camshaft lobe (exhaust valves)
- B. Camshaft lobe (intake valves)
- C. Camshaft journal (timing chain side)
- D. Camshaft journal (spark plug side)

CAMSHAFT LOBE (EXHAUST)		
ENGINE	NEW	32.860 mm to 33.060 mm (1.294in to1.302in)
	SERVICE LIMIT	32.840 mm(1.293in)

CAMSHAFT LOBE (INTAKE)		
ENGINE	NEW	32.960 mm to 33.160 mm (1.298in to1.306in)
	SERVICE LIMIT	32.940 mm(1 .297in)

Measure camshaft bearing in cylinder head . Refer to CYLINDER HEAD INSPECTION in this subsection.

Camshaft Journal Inspection

Check each journal for scoring, scuffing, cracks or other signs of wear.

Measure camshaft journal using a micrometer .

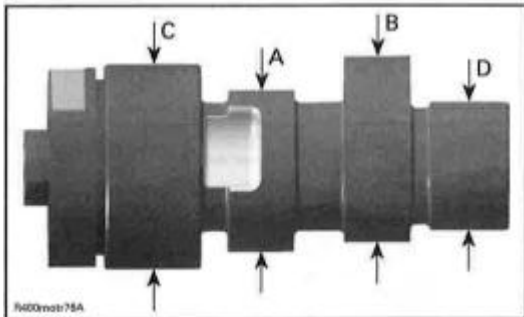

- A. Camshaft lobe (exhaust valves)
- B. Camshaft lobe (intake valves)
- C. Camshaft journal (timing chain side)
- D. Camshaft journal (spark plug side)

CAMSHAFT JOURNAL (TIMING CHAIN SIDE)	
NEW	34.959mm to 34.975mm (1 3763 in to1 .377 in)
SERVICE LIMIT	34.950 mm(1 .376 in)

CAMSHAFT JOURNAL (SPARK PLUG SIDE)	
NEW	21 959 mm to 21 980 mm (.8645in to.8654in)
SERVICE LIMIT	21 .950 mm(.8642 in)

Camshaft Installation

For installation, reverse the removal procedure. Pay attention to the following details.

The camshafts are not identical in design. Do not invert the camshafts during assembly. Any mix-up of the components will lead to engine damage. Place the camshaft retaining plate in the slot of the camshaft.



- 1. Direction of movement
- 2. Camshaft retaining plate
- 3. Slot retaining camshaft

For other parts, refer to proper installation procedure.

CYLINDER HEAD

Cylinder Head Access

Refer to BODY and remove:

- Lower console
- LH and RH lateral console panels.
- Remove LH passenger handhold bar.



LH PASSENGER HANDHOLD BAR

On cylinder2, remove the shift cable bracket.

Refer to INTAKE MANIFOLD subsection to remove following parts:

- Plenum, for cylinder 1
- Intake manifold.

Cylinder Head Removal

The removal procedure is the same for both cylinder heads.

Drain coolant. Refer to ENGINE COOLANT REPLACEMENT in the PERIODIC MAINTENANCE PROCURES subsection.

NOTE: Before removing cylinder head, blow out remaining coolant by air pressure. During cylinder head removal, the remaining coolant in cylinder head could overflow into the engine and a little quantity of coolant could drop into the engine. In this case, the engine oil will be contaminated.

Disconnect spark plug wire.

Disconnect temperature sensor connector, located at rear cylinder head.

Remove the valve cover and its gasket (see VALVECOVER in this subsection).

Refer to TIMING CHAIN subsection and remove the following parts:

- Timing chain tensioner
- Camshaft timing gear.

First remove the M6 cylinder head screws, then the M10 cylinder head screws.



1. Cylinder head screws M10
2. Cylinder head screws M6

Pull up cylinder head.

Remove timing chain guide (fixed).

Remove and discard the cylinder head gasket,

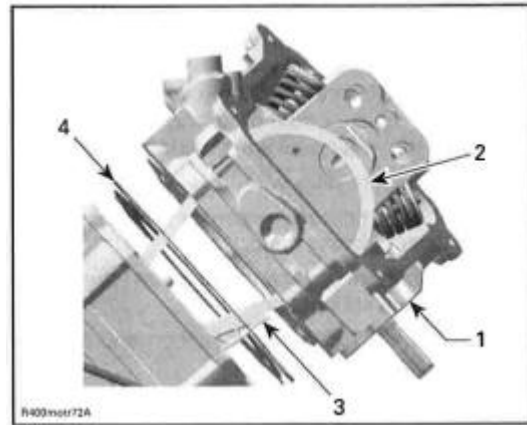

1. Cylinder head
2. Timing chain
3. Chain guide (fixed)
4. Cylinder head I gasket

Cylinder Head Inspection

Inspect timing chain guide (fixed) for wear, cracks or other damages. Replace if necessary.

Check for cracks between valve seats, if so, replace cylinder head.

Check mating surface between cylinder and cylinder head for contamination. If so, clean both surfaces.

Clean oil support through the cylinder head from contamination.

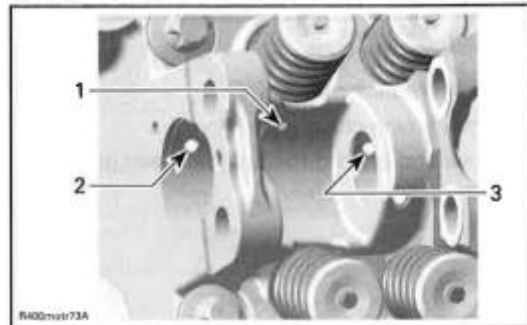

1. Oil port to lubricate camshaft lobes intake /exhaust
2. Oil supply to camshaft bearing journal (timing chain side)
3. Oil supply to camshaft bearing journal (spark plug side)

Cylinder Head Camshaft Bearing Inspection

Measure camshaft bearing in cylinder head.

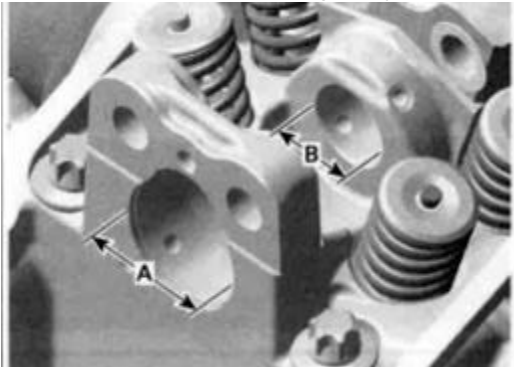

- A. Cam shaft bearing (timing chain side)
- B. Cam shaft bearing (spark plug side)

CAMSHAFT BEARING (TIMING CHAIN SIDE)	
NEW	35.000 mm to 35.025mm (1.378in to 1.3789in)
SERVICE LIMIT	35.040 mm (1.3795 in)
CAMSHAFT BEARING (SPARK PLUG SIDE)	
NEW	22.000mm to 22.021 mm (.8661 in to .867in)
SERVICE LIMIT	22.040 mm (.8677 in)

Cylinder Head Installation

NOTE: Never invert front and rear cylinder heads.

For installation, reverse the removal procedure. Pay attention to the following details.

Ensure dowel pins are in place.

Timing chain guide (fixed) has to be fixed between cylinder and cylinder head.



TYPICAL

- 1. Timing chain guide (tensioner side) mounted in crankcase
- 2. Timing chain guide (fixed) between cylinder and cylinder head

Install a NEW cylinder head gasket.

Install cylinder head screws in correct position.

Cylinder head screws have different sizes and lengths.



- 1. Location no. 1
- 2. Location no. 2

CYLINDER HEAD SCREW IDENTIFICATION		
engine	Location no. 1	M10×159
	Location no. 2	M6×105

Tighten M10 cylinder head screws FIRST as per following specifications.



TIGHTENING SEQUENCE-M10 CYLINDER HEAD SCREWS

M10 CYLINDER HEAD SCREWS	
Tightening torque (step1)	20N·m±1N·m (15lbf·ft±1 lbf·ft)

M10 CYLINDER HEAD SCREWS	
Tightening torque (step2)	180° +/-5°

Tighten M6 cylinder head screws as per following specification.



1. M6 Screws

Check timing chain guide (tensioner side) for movement.

On cylinder1, install the plenum bracket, refer to INTAKE MANIFOLD subsection.



VALVE SPRINGS

Valve Spring Removal

Refer to following procedures in this subsection to remove:

- CAMSHAFT
- CYLINDER

Compress valve spring.

REQUIRED TOOL	
VALVE SPRING COMPRESSOR	
VALVE SPRING COMPRESSOR CUP	

△ WARNING	
Always wear safety glasses when disassembling valve springs. Be careful when unlocking valves. Components could fly away because of the strong spring preload.	



LOCATE VALVE SPRING COMPRESSOR CLAMP IN CENTER OF THE VALVE

Remove valve cotters,

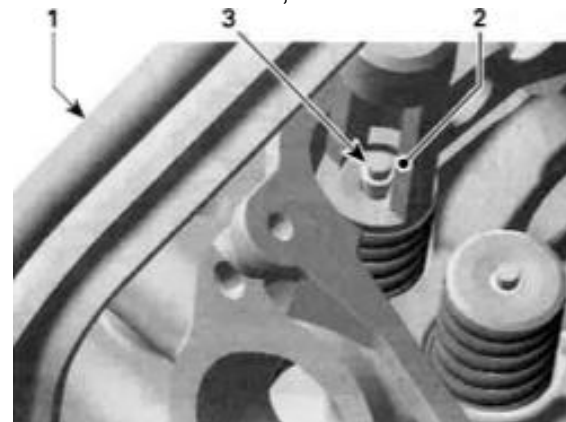

1. Valve spring compressor clamp
2. Valve spring compressor cup
3. Valve cotter

Remove tools and withdraw valve spring retainer and valve spring.



- 1. Valve spring retainer
- 2. Valve spring

Valve Spring Inspection

Check valve spring for visible damage. If so, re- place valve spring.

Check valve spring for free length and straightness.

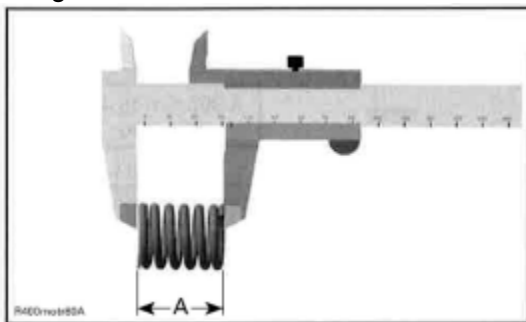

A. Valve spring length

VALVE SPRING FREE LENGTH	
NEW	40.81 mm(1.607in)
SERVICE LIMIT	39.00 mm(1.535in)

Replace valve springs if not within specifications.

Valve Spring Installation

For installation, reverse the removal procedure.

Pay attention to the following details.

Colored area of the valve spring must be placed on top.

To ease installation of cotter pins, apply oil or grease on them so that they remain in place while releasing the spring.

NOTE: Valve cotter must be properly engaged in valve stem grooves.



- 1. Position of the valve spring
- 2. Valve cotter

After spring is installed, ensure it is properly locked by tapping on valve stem end with a soft hammer so that valve opens and closes a few times.

Warning: An improperly locked valve spring will cause engine damage.

VALVES

Valve Removal

Remove valve spring, see VALVE SPRING in this subsection.

Push valve stem, then pull valves (intake and exhaust) out of valve guide.



- 1. Intake valve 31mm
 - 2. Exhaust valve 27 mm
- Remove valve stem seal and discard it

REQUIRED TOOL	
SNAP-ON PLIERS	



Valve Inspection

Whenever valves are removed always inspect valve guides. Refer to VALVE GUIDES in this subsection.

Valve Stem Seal

Always install NEW seals whenever valves are removed.

Valve

Inspect valve surface, check for abnormal stem wear and bending. If out of specification, replace by a new one.



VALVE OUT OF ROUND (INTAKE AND EXHAUST VALVES)	
NEW	0.005mm(.0002 in)
SERVICE LIMIT	0.06 mm(.0024in)

Valve Stem

Measure valve stem in three places using a micrometer .

Replace valve if valve stem is out of specification or has other damages such as wear or friction surface.

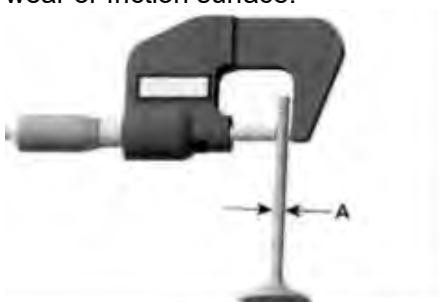

A. Valve stem diameter

VALVE STEM DIAMETER	
EXHAUST VALVE	
NEW	4.956mm to4.970 mm (.1951 in to.1957in)
SERVICE LIMIT	4.930mm(.1941 in)
INTAKE VALVE	
NEW	4.966mm to4.980 mm (.1955in to.1961 in)
SERVICE LIMIT	4.930mm(.1941 in)

Valve Face and Seat

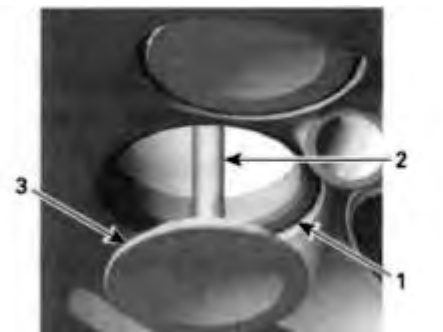

1. Valve seat
2. Exhaust valve contaminated area
3. Valve face (contact surface to valve seat)

Check valve face and seat for burning or pittings and replace valve or cylinder head if there are signs of damage.

Ensure to seat valves properly. Apply some lapping compound to valve face and work valve on its seat with a lapping tool (see VALVE GUIDES in this subsection).

Measure valve face contact width.

NOTE: The location of contact area should be in center of valve seat.

Measure valve seat width using a caliper .

VALVE SEAT CONTACT WIDTH	
EXHAUST VALVE	
NEW	1.25mm to1.55mm (.049in to.061 in)
SERVICE LIMIT	2.00 mm(.079 in)
INTAKE VALVE	
NEW	1.05mm to1.35mm (.041 in to.053in)
SERVICE LIMIT	1.80mm(.071 in)

If valve seat contact width is too wide or has dark spots, replace the cylinder head.

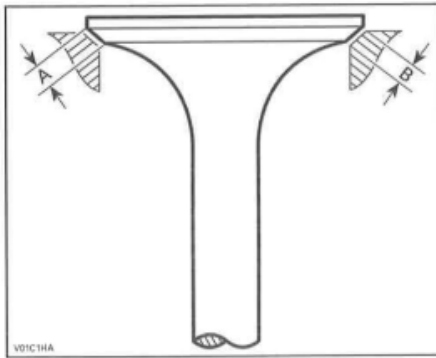

- A. Valve face contact width
- B. Valve seat contact width

Valve Installation

For installation, reverse the removal procedure. Pay attention to the following details.

Install a NEW valve stem seal. Make sure thrust washer is installed before installing seal.

Apply engine oil on valve stem and install it.

Be careful when valve stem is passed through sealing lips of valve stem seal.

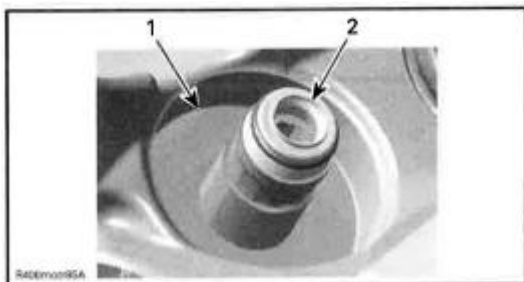

- 1. Thrust washer
- 2. Sealing lips of valve stem seal

To ease installation of cotter pins, apply oil or grease on them so that they remain in place while releasing the spring.

After spring is installed, ensure it is properly locked by tapping on valve stem end with a soft hammer so that valve opens and closes a few times.

An improperly locked valve spring will cause engine damage.

VALVE GUIDES

Valve Guide Inspection

Always replace valve stem seals whenever valve guides are removed.

Measure valve guide in three places using a small bore gauge.

NOTE: Clean valve guide to remove carbon deposits before measuring.

Replace valve guide if it is out of specification or has other damages such as wear or friction surface.

VALVE GUIDE DIAMETER (INTAKE AND EXHAUST VALVES)	
NEW	4.998mm to 5.018mm (.1968in to .1976in)
SERVICE LIMIT	5.050 mm (.1988 in)

Valve Guide Removal

Refer to following procedures in this subsection to remove:

- Cylinder head
- Valves.

NOTE: Clean valve guide area from contamination before removal.

Drive the valve guide out of cylinder head.

REQUIRED TOOL	
Hammer	
VALVE GUIDE REMOVER 5 MM	



- 1. Valve guide remover
- 2. Valve guide

Valve Guide Installation

For installation, reverse the removal procedure. Pay attention to the following details.

Clean the valve guide bore before reinstalling the valve guide into cylinder head.

Install valve guide.

REQUIED TOOL	
VALVE GUIDE INSTALLER	



1. Valve guide installer
2. Valve guide

NOTE: Apply LOCTITE767 (ANTISEIZE LUBRICANT) on valve guide prior to install it into the cylinder head.

Push valve guide in the cold cylinder head as per following illustration.

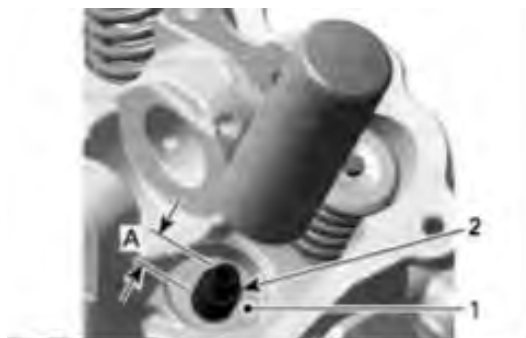

1. Thrust surface of cylinder head
2. Valve guide
- A. Measurement from thrust surface to valve guide top

VALVE GUIDE(MEASUREMENT“A”	
NEW	14.00mm to 14.40mm (.5512 in to .5669 in)

Apply some lapping compound to valve face and work valve on its seat with a lapping tool.

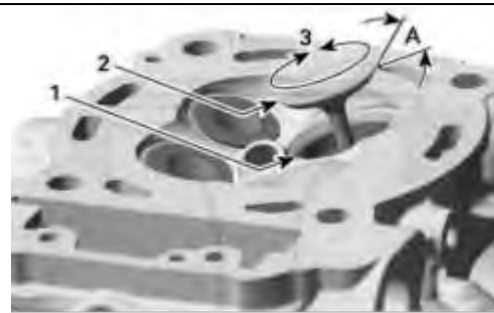

1. Valve seat
2. Valve face (contact surface to valve seat)
3. Turn valve while pushing against cylinder head
- A. Valve seat angle 45°

NOTE: Ensure to seat valves properly. Apply marking paste to ease checking contact pattern. Repeat procedure until valve seat/valve face fits together.

CYLINDER

Cylinder Removal

Refer to TUMING CHAIN subsection and remove the following parts:

- Timing chain tensioner
- Camshaft timing gear.

Remove the cylinder head (see CYLINDER HEAD in this subsection).

Pull cylinder.

Discard cylinder base gaskets.

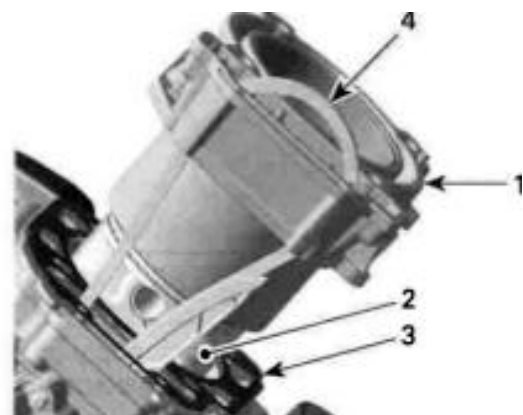

1. Cylinder
2. Piston assembly
3. Cylinder base gasket
4. Camshaft timing chain

Cylinder Inspection

Check cylinder for cracks, scoring and wear ridges on the top and bottom of the cylinder. If so, replace cylinder.

Cylinder Taper

Measure cylinder bore at 3 recommended positions.

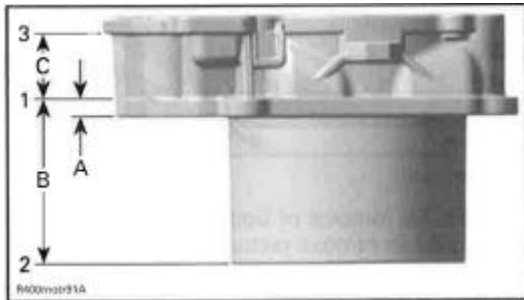

- A. First measurement (from cylinder bottom)
- B. Second measurement
- C. Third measurement

CYLINDER TAPER MEASUREMENTS		
ENGINE	MEASUREMENT	SPECIFICATION
engine	A	5mm(.197 in)
	B	58 mm(2.283 in)
	C	52 mm(2.047 in)

CYLINDER TAPER SPECIFICATION	
NEW (MAXIMUM)	0.038mm(.0015in)
SERVICE LIMIT	0.090 mm(.0035in)

Distance between measurements should not exceed the service limit mentioned above. Otherwise, replace cylinder and piston rings.

Cylinder Out of Round

Measure cylinder diameter in piston axis direction from top of cylinder . Take another measurement 90° from first one and compare .

NOTE: Take the same measuring points like described in CYLINDER TAPER above.

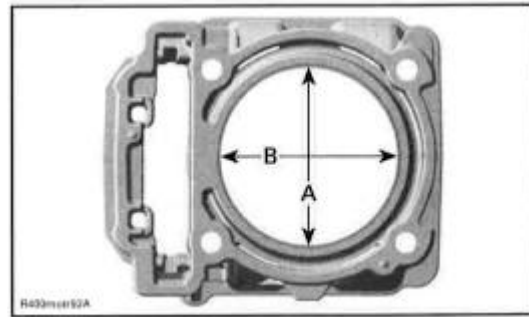

- A. Perpendicular to crankshaft axis
- B. Parallel to crankshaft axis

CYLINDER OUT OF ROUND	
NEW (MAXIMUM)	0.015mm(.0006in)
SERVICE LIMIT	0.020 mm(.0008 in)

Cylinder Installation

For installation, reverse the removal procedure. Pay attention to the following details.

Always replace cylinder base gasket before installing the cylinder.

NOTE: Make sure piston rings are properly spaced, refer to PISTON in this subsection.

Apply engine oil:

- In the bottom area of the cylinder bore
- On the piston rings
- On the compressor tool.

Compress piston rings.

REQUIRED TOOL	
PISTON RING COMPRESSOR	

First mount cylinder 2.

NOTE: The cylinder can not be pushed fully over the piston unless the piston is located at TDC.

Then remove the CRANKSHAFT LOCKING BOLT.

Crank the engine further and position piston1 at TDC.

Mount cylinder 1.

Put timing chain through the chain pit then put the cylinder in place.

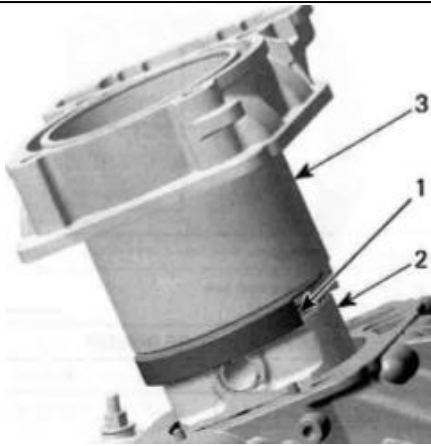

- 1. Piston ring compressor tool
- 2. Piston
- 3. Cylinder

Chain guide has to be fixed between cylinder and cylinder head.

NOTE: After both cylinders are installed, turn crankshaft until piston of cylinder2 is at TDC and lock crankshaft. Refer to CRANKSHAFT BOTTOM END subsection. Install cylinder head and the other parts in accordance with the proper installation procedures.

PISTON

Piston Removal

Refer to following procedures in this subsection to remove:

- Cylinder head
- Cylinder.

Place a rag under piston and in the area of timing chain compartment.

△ WARNING

Piston circlips are spring loaded

Remove one piston circlip and discard it.



- 1. Piston circlip

NOTE: The removal of both piston circlips is not necessary to remove piston pin.

Push piston pin out of piston.

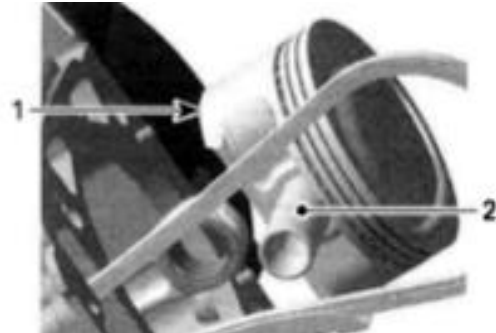

- 1. Piston
- 2. Piston pin

Detach piston from connecting rod.

Piston Inspection

Inspect piston for scoring, cracking or other damages. Replace piston and piston rings if necessary.

Using a micrometer, measure piston at 8mm (.315in) perpendicularly (90°) to piston pin.

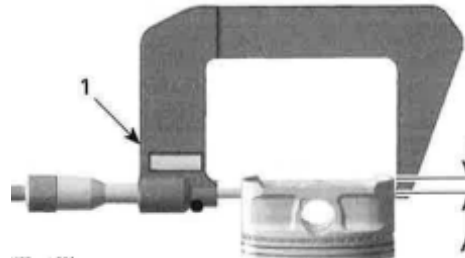

- 1. Measuring perpendicularly (90°) to piston pin

A. 8mm (.375in)

The measured dimension should be as described in the following tables. If not, replace piston.

PISTON MEASUREMENT	
NEW	90.950 mm to 90.966mm (3.5807in to 3.5813in)
SERVICE LIMIT	90.850 mm (3.577 in)

Piston/Cylinder Clearance

Adjust and lock a micrometer to the piston dimension.

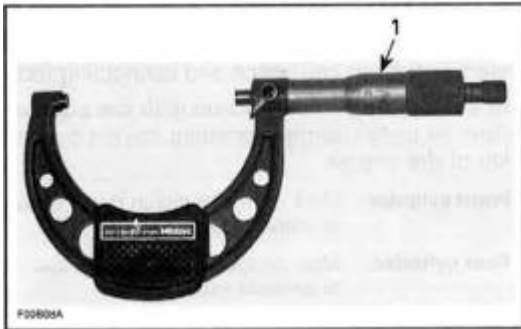

1. Micrometer set to the piston dimension

With the micrometer set to the dimension, adjust a cylinder bore gauge to the micrometer dimension and set the indicator to 0(zero).

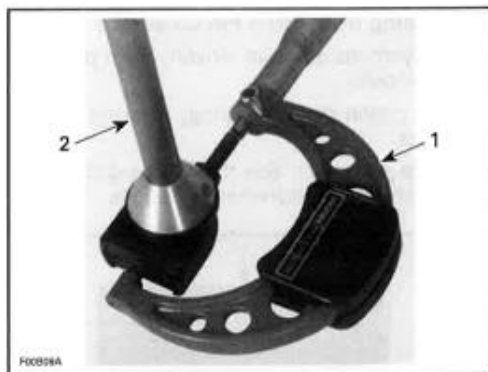

1. Use the micrometer to set the cylinder bore gauge
2. Dial bore gauge

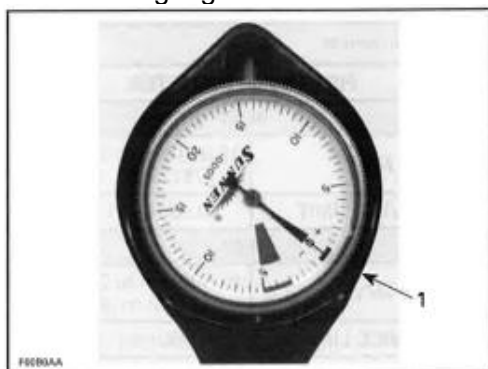

TYPICAL
1. Indicator set to 0(zero)

Position the dial bore gauge 20 mm (.787 in) above cylinder base, measuring perpendicularly (90°) to piston pin axis.

Read the measurement on the cylinder bore gauge. The result is the exact piston/cylinder wall clearance.

PISTON/CYLINDER CLEARANCE	
NEW	0.027mm to 0.057mm (.0011 in to .0022in)
SERVICE LIMIT	0.100 mm(.0039 in)

NOTE: Make sure used piston is not worn. If clearance exceeds specified tolerance, replace piston by a new one and measure piston/cylinder clearance again.

NOTE: Make sure the cylinder bore gauge indicator is set exactly at the same position as with the micrometer, otherwise the reading will be false.

Connecting Rod/Piston Pin Clearance

Using synthetic abrasive woven, clean piston pin from deposits .

Inspect piston pin for scoring, cracking or other damages.

Measure piston pin . See the following illustration for the proper measurement positions.

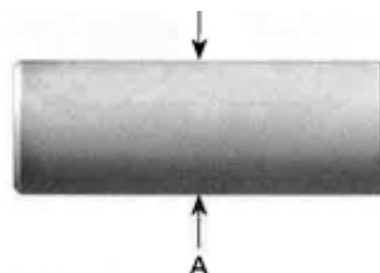

A. Piston pin diameter

PISTON PIN DIAMETER	
NEW	21.996mm to 22.000 mm (.866in to .8661 in)
SERVICE LIMIT	21.980 mm(.8654in)

Replace piston pin if diameter is out of specifications.

Measure inside diameter of connecting rod small end bushing .

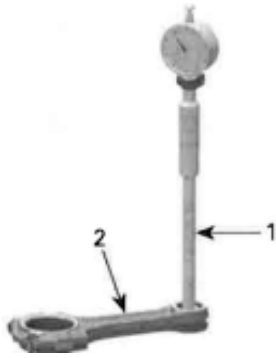

- 1. Bore gauge
- 2. Connecting rod

CONNECTING ROD SMALL END DIAMETER	
NEW	20.010 mm to 20.020 mm (.7878in to .7882in)
SERVICE LIMIT	20.050 mm (.7894in)

Replace connecting rod if diameter of connecting rod small end is out of specifications. Refer to BOTTOM END subsection for removal procedure. Compare measurements to obtain the connecting rod/piston pin clearance.

CONNECTING ROD/ PISTON PIN CLEARANCE	
SERVICE LIMIT	0.080mm (.0031 in)

Piston Installation

For installation, reverse the removal procedure. Pay attention to the following details. Apply engine oil on the piston pin. Insert piston pin into piston and connecting rod. For each cylinder, Install piston with the punched arrow on piston dome is pointing toward the rear side of the engine.
 Front cylinder: Mark on top of piston must show to intake side.
 Rear cylinder: Mark on top of piston must show to exhaust side.



- 1. Piston of cylinder 1
- 2. Mark on piston must show to intake side of cylinder 1
- 3. Piston of cylinder 2
- 4. Mark on piston must show to exhaust side of cylinder 2

Use the piston appropriate circlip installer to assemble the NEW piston circlip as per following procedure:

Always replace disassembled piston circlip(s) by NEW ones. Place a rag on cylinder base to avoid dropping the circlip inside the engine.

Place circlip in sleeve as per following illustration.



CORRECT POSITION OF THE PISTON CIRCLIP

PISTON RINGS

Ring Removal

Remove the piston (see PISTON in this subsection).

Ring Inspection

Ring/Piston Groove Clearance

Using a feeler gauge measure each ring/piston groove clearance .

If the clearance is too large, the piston and the piston rings should be replaced.

RING END GAP	
UPPER COMPRESSION RING	
NEW	0.03mm to 0.07mm (.0012in to .0028in)
SERVICE LIMIT	0.150mm(.0059in)
LOWER COMPRESSION RING	
NEW	0.02 mm to 0.06mm (.0008in to .0024in)
SERVICE LIMIT	0.150mm(.0059in)
OIL SCRAPER RING	
NEW	0.01 mm to 0.18mm (.0004in to .0071 in)
SERVICE LIMIT	0.250mm(.0098in)

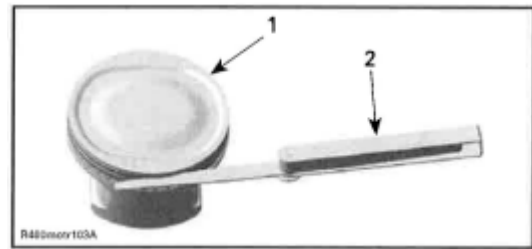

1. Piston
2. Feeler gauge

Ring End Gap

RING/PISTON GROOVE CLEARANCE	
UPPER COMPRESSION RING	
NEW	0.20 mm to 0.40 mm (.008in to .016in)
SERVICE LIMIT	0.60 mm(.024in)
LOWER COMPRESSION RING	
NEW	0.20 mm to 0.40mm (.008in to .016in)
SERVICE LIMIT	0.70 mm(.028 in)
OIL SCRAPER RING	
NEW	0.20 mm to 0.70mm (.008in to .028in)
SERVICE LIMIT	1 .00 mm(.039in)

To measure the ring end gap place the ring in the cylinder in the area of 8mm to 16mm (5/16in to 5/8in) from top of cylinder.

NOTE: In order to correctly position the ring in the cylinder, use piston as a pusher.

Using a feeler gauge, check ring end gap.

Replace ring if gap exceeds above described specified tolerance.

Ring Installation

For installation, reverse the removal procedure. Pay attention to the following details.

NOTE: Use a ring expander to prevent breakage during installation. The oil ring must be installed by hand.

NOTE: First install spring and then rings of oil scraper ring.

Install the oil scraper ring first, then the lower compression ring with the word "N" and "TOP" facing up, then the upper compression ring with the word "N" and "TOP" facing up.

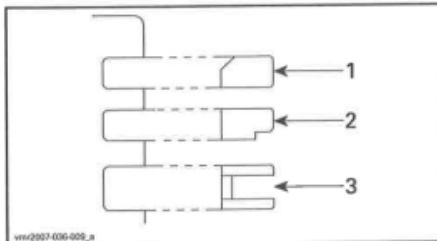

1. Upper compression ring
2. Lower compression ring
3. Oil scraper ring

Ensure that top and second rings are not interchanged.

Check that rings rotate smoothly after installation.

Space the piston ring end gaps 120° apart and do not align the gaps with the piston pin bore or the thrust side axis.

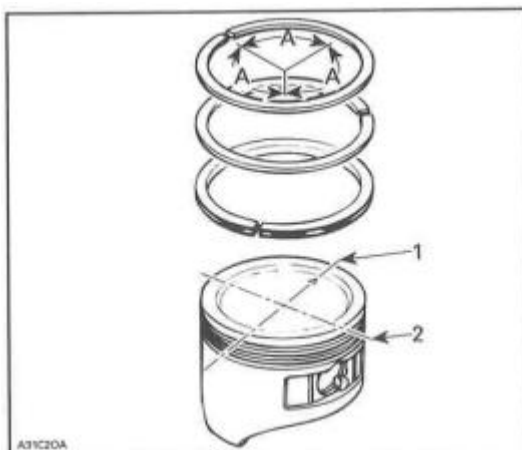

1. DO NOT align ring gap with piston thrust side axis
 2. DO NOT align ring gap with piston pin bore axis
- A. 120°

TIMING CHAIN

The engine is equipped with two timing chains. One of the timing chain is located on engine MAG side behind the magnet cover. The second timing chain is located on engine PTO side behind the PTO cover.

Removal of magneto side timing chain

Remove:

- valve cover, chain tensioner and camshaft timing gear (refer to CYLINDER AND HEAD)
- magneto cover and rotor (refer to MAGNETO SYSTEM)
- timing chain guide and lower timing chain guide.

1. Timing chain
2. Timing chain guide
3. Lower timing chain guide

Carefully pull the timing chain sideward and down from the crankcase.

NOTE: Mark the operating direction of the timing chain before removal.

Removal of PTO side timing chain

Remove:

- valve cover, chain tensioner and camshaft timing gear (refer to CYLINDER AND HEAD section)
- PTO cover (refer to PTO COVER)

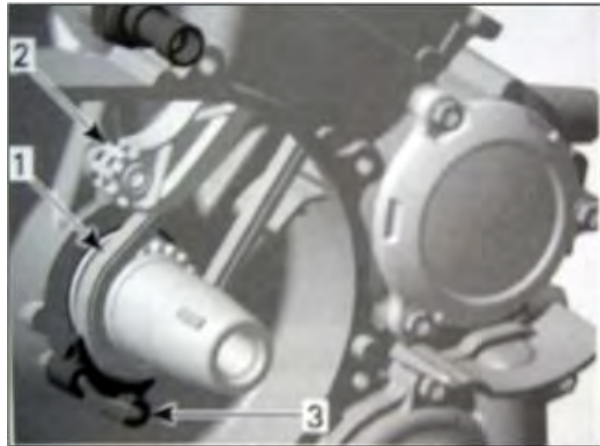

- Intermediate gear and breather gear (refer to DRIVE GEARS)
- Timing chain guide and lower timing chain guide (see illustration above).

Carefully pull the timing chain sideward and down from the crankcase.

NOTE: Mark the operating direction of the timing chain before removal.

Timing chain inspection

Inspection is the same for both timing chains.

NOTE: Check timing chain on camshaft timing gear for excessive radial play.

Check chain condition for wear and teeth condition.

If chain is excessively worn or damaged, replace it as a set (camshaft timing gear and timing chain).

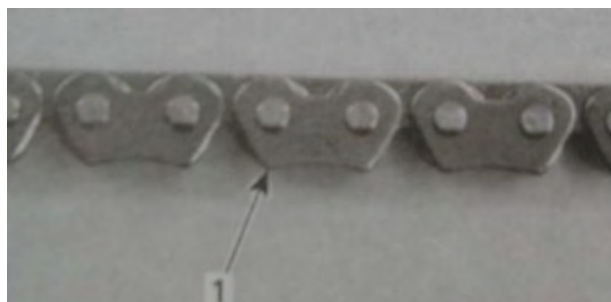

Timing chain installation

Installation is the same for both timing chains.

The installation is essential the reverse of the removal procedure, but pay attention to the following details.

NOTE: Ensure to perform proper valve timing. Lock crankshaft (see CRANKSHAFT) and camshaft at TDC ignition (refer to CYLINDER AND HEAD section).

Install timing chain with camshaft timing gear then, adjust chain tension (refer to CYLINDER AND HEAD section).

CAUTION: Improper valve timing will damage engine components.

ENGINE DRIVE SHAFT

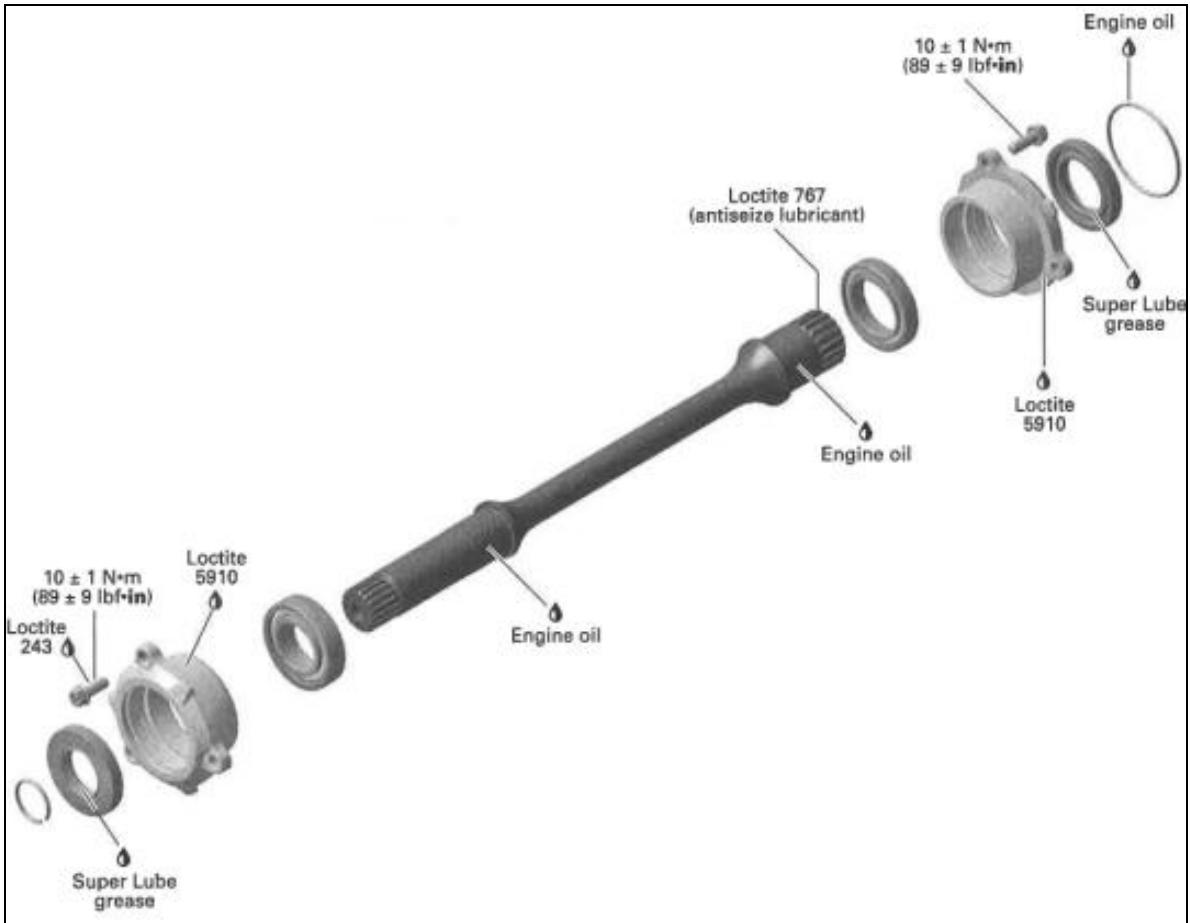

CRANKSHAFT

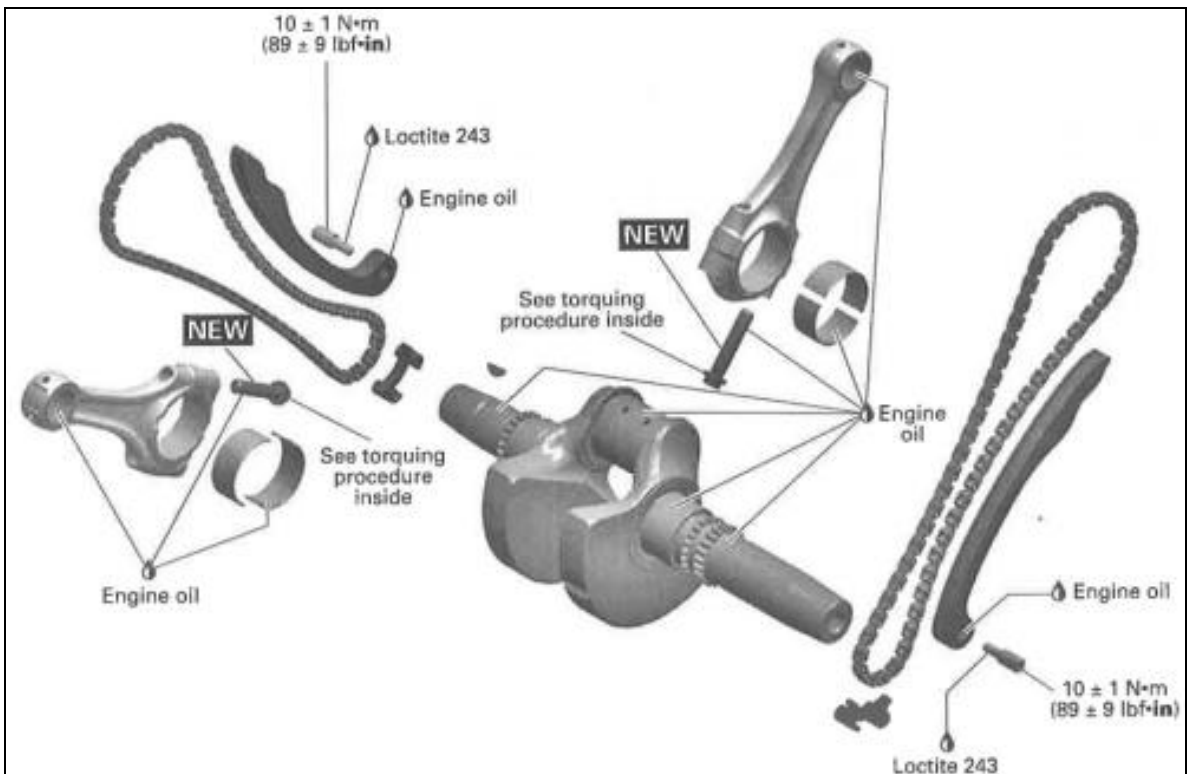

CRANKCASE AND PTO COVER

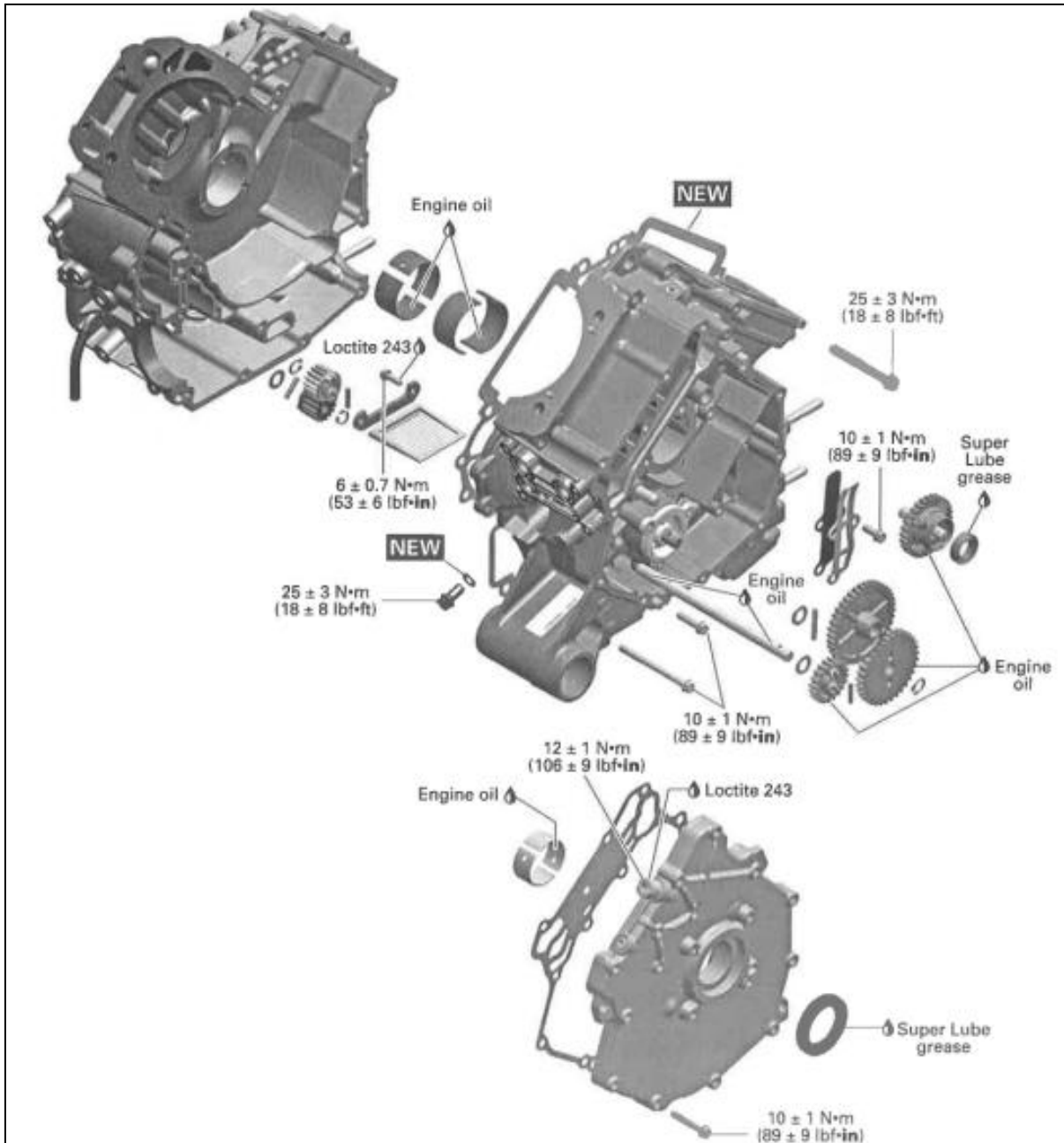

GENERAL

IMPORTANT: Note position of parts on disassembly. This may help to find the root cause of a problem. A component that is not replaced should be reinsta1led in the same position as originally mounted.

PROCEDURES

ENGINE DRIVE SHAFT

NOTE: The engine drive shaft transmits the power from the gearbox to the front differential and is located inside the crankcase.

Engine Drive Shaft Removal

Remove the engine. Refer to ENGINE REMOVAL AND INSTALLATION subsection.

Rear Bearing Cover Removal

Detach gearbox from engine, refer to GEARBOX AND 4×4 COUPLING UNIT subsection.

At rear of engine, remove the bearing cover and its O-ring.



1. Bearing cover screws
2. O-ring
3. Bearing cover gearbox side

Front Bearing Cover Removal

Remove the bearing cover at the front of the engine.

Check ends of the circlip for sharp edges or burr before removing the drive shaft, to avoid damaging the oil seal.

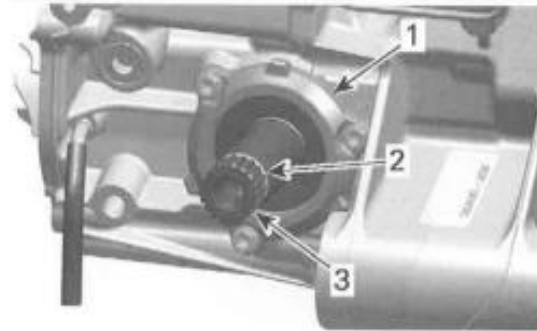

1. Bearing cover front drive side
2. Circlip
3. Drive shaft

Engine Drive Shaft Removal

Split crankcase , refer to CRANKCASE in this subsection.

Remove engine drive shaft from the crankcase.



1. Crankcase MAG side
2. Engine drive shaft

Engine Drive Shaft Inspection

Replace oil seals and/or O-ring (bearing cover gearbox side) if they are brittle , hard or damaged. Check drive shaft bearings for contamination and/or metal shavings. Check if bearings turn freely and smoothly. Replace if necessary.

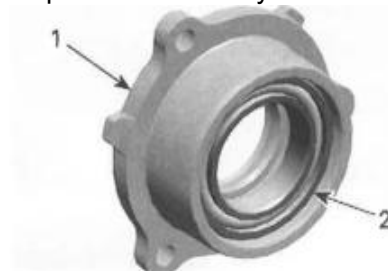

1. Bearing cover
2. Drive shaft bearing

Check drive shaft for cracks, bend, pitting or other visible damages.
 Check drive shaft splines for wear or damages.
 Check oil seal running surface of the drive shaft for scratches. Replace if necessary.

Engine Drive Shaft Installation

The installation is the reverse of removal procedure. Pay attention to the following details.

Clean all metal components in solvent.
 Crankcase surfaces and bearing covers are best cleaned using a combination of LOCTITE CHISEL (GASKET REMOVER) and a brass brush. Brush a first pass in one direction then make the final brushing perpendicularly (90°) to the first pass.

Do not wipe with rags. Use a new clean hand towel only.

Use a suitable installer for installing bearings.

Use LOCTITE5910 on mating Surfaces.

IMPORTANT: When beginning the application of the bearing cover sealant, the assembly and the first torquing should be done within 10 minutes.

it is suggested to have all you need on hand to save time.

Use a plexiglass plate and apply some sealant on it. Use a soft rubber roller 50mm-75mm (2in-3in), available in arts products suppliers for printing, and roll the sealant to get a thin uniform coat on the plate (spread as necessary). When ready, apply the sealant on bearing cover surfaces.

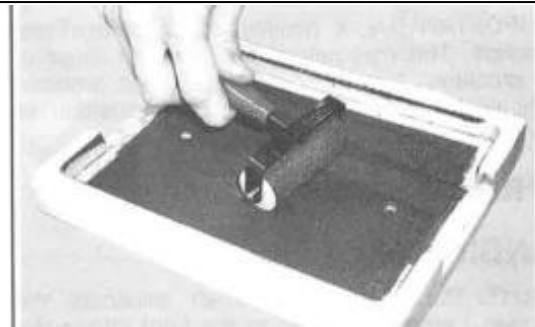

Do not apply in excess as it will spread out inside crankcase.

NOTE: It is recommended to apply this specific sealant as described here to get a uniform application without lumps. If you do not use the roller method, you may use your finger to uniformly distribute the sealant (using a finger will not affect the adhesion).

Rear Bearing Cover Installation

For bearing cover installation on gearbox side, protect the oil seal to avoid damaging the sealing lip.

REQUIRED	
DRIVE SHAFT OIL SEAL	

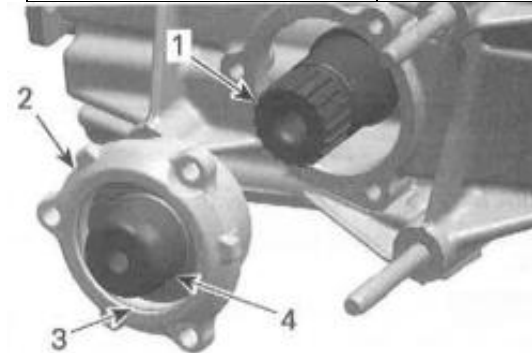

- 1. Drive shaft
- 2. Bearing cover gearbox side
- 3. O-ring
- 4. Protection sleeve

REQUIRED	
Tightening torque	10N·m ± 1 N·m (89lbf·in ± 9lbf·in)

Front Bearing Cover Installation

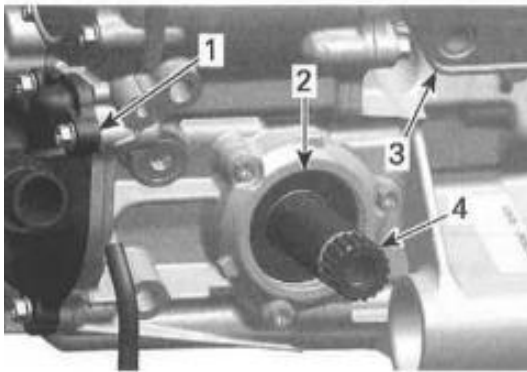

FRONT OF ENGINE

- 1. Water pump cover
- 2. Oil seal front side
- 3. Oil cover
- 4. Drive shaft

FRONT BEARING COVER SCREWS	
Service product	LOCTITE243 (BLUE)
Tightening torque	10N·m ± 1 N·m (89lbf·in ± 9lbf·in)

Engine Drive Shaft Installation

Finally check for axial play of the drive shaft

FRONT OIL SEAL

(ENGINE DRIVE SHAFT)

Front Oil Seal Replacement

(Engine Drive Shaft)

NOTE: The front oil seal can be replaced with the engine installed.

1. Remove front propeller shaft.
2. Remove adapter sleeve between propeller shaft and front engine drive shaft.
3. Remove the front bearing cover, refer to ENGINE DRIVE SHAFT REMOVAL / INSTALLATION in this subsection.
4. Remove drive shaft seal from bearing cover.



- 1. Bearing cover
- 2. Oil seal

5. Install drive shaft oil seal using the following



- 1. Bearing cover
- 2. Oil seal
- 3. Oil seal installer

REQUIRED	
DRIVE SHAFT OIL SEAL	

6. Reinstall remaining parts in the reverse order of removal.

REAR OIL SEAL

(ENGINE DRIVE SHAFT)

Rear Oil Seal Replacement

(Engine Drive Shaft)

1. Remove rear bearing cover , refer to ENGINE DRIVE SHAFT REMOVAL / INSTALLATION in this subsection.
2. Remove drive shaft seal from bearing cover.
3. Remove O-ring from bearing cover.



- 1. Bearing cover
- 2. O-ring

4. Install drive shaft oil seal using the following tool.

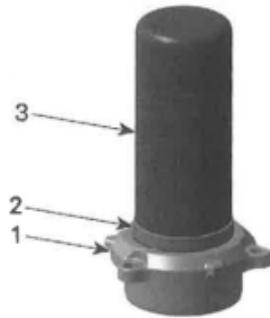

- 1. Bearing cover
- 2. Oil seal
- 3. Oil seal installer

REQUIRED	
DRIVE SHAFT OIL SEAL	

5. Install O-ring in rear bearing cover.



- 1. O-ring
- 2. Bearing cover

6. Reinstall remaining parts in the reverse order of removal.

PTO COVER OIL SEAL

To replace oil seal it is not necessary to remove engine from vehicle.

PTO Oil Seal Removal

Refer to CONTINUOUSLY VARIABLE TRANSMISSION (CVT) subsection to remove the following parts:

- CVT cover
- Drive pulley
- Driven pulley
- CVT air guide.

Remove oil seal with a small flat screwdriver.

CAUTION Avoid scoring surfaces with tool.

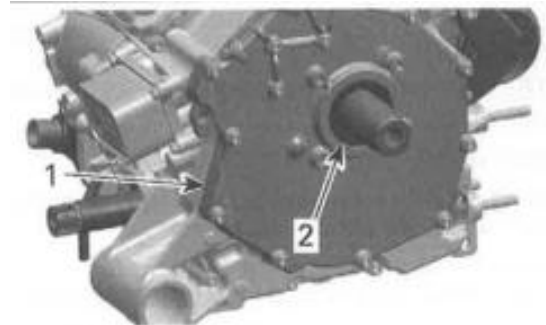

- 1. PTO cover
- 2. Oil seal

PTO Oil Seal Inspection

Check oil seal running surface of crankshaft PTO side for grooves. Replace if necessary.

PTO Oil Seal Installation

The installation is the reverse of the removal procedure.

Pay attention to the following details.

CAUTION Oil seal must be installed with sealing lip toward the engine.

Push oil seal in place.

REQUIRED	
PTO COVER OIL SEAL	

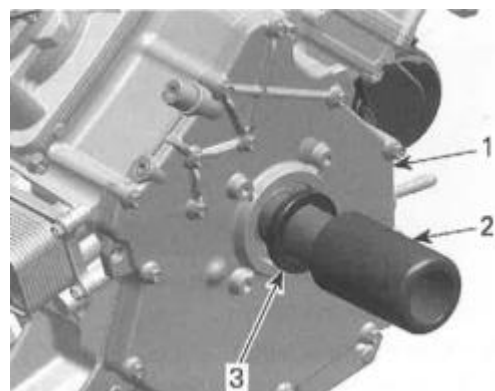

- 1. PTO cover
- 2. Oil seal installer
- 3. Oil seal

PTO COVER

PTO Cover Removal

Refer to CONTINUOUSLY VARIABLE TRANSMISSION (CVT) subsection to remove the following parts:

- CVT cover
- Drive pulley
- Driven pulley
- CVT air guide.

Disconnect vent hose.

Remove PTO cover screws and pull PTO cover.

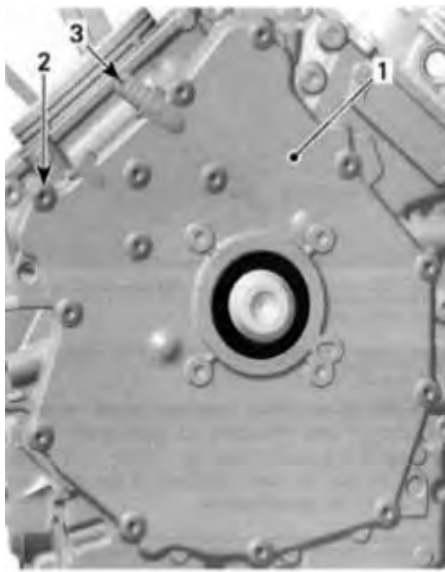

- 1. PTO cover
- 2. PTO cover screws
- 3. Vent hose nipple

PTO Cover Inspection

Check the PTO cover for cracks or other damage. Replace PTO cover if damaged. Clean oil breather bore in PTO cover from contamination with part cleaner then use pressurized air to dry it.

▲WARNING
Always wear skin and eye protection. Chemicals can cause skin rash, skin burns and severe eye injury.

Check surface of sealing sleeve for wear or other damages. Replace PTO cover if damaged.

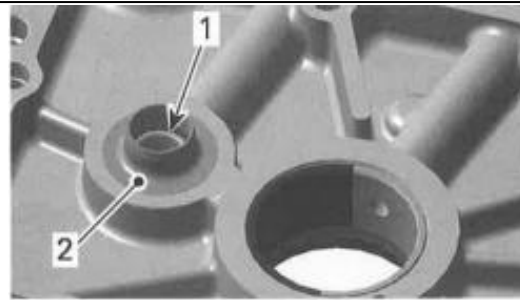

- 1. Oil breather bore
- 2. Surface of sealing sleeve

Check plain bearings for scorings or other damages.

NOTE: Measure plain bearing inside diameter (PTO cover) and compare to crankshaft journal Diameter (PTO cover bearing). Refer to CRANK SHAFT in this section. Replace if the measurement is out of specification.

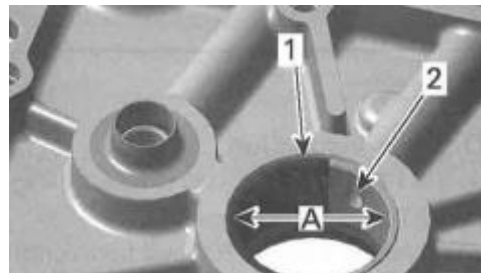

- 1. Plain bearing
- 2. Oil bore
- A. Measure plain bearing inside diameter

PLAIN BEARING INSIDE DIAMETER (PTO COVER)	
SERVICE LIMIT	34.120 mm(1 .3433 in)

Plain Bearing Replacement (PTO Cover)

Plain Bearing Removal

Unless otherwise instructed, never use a hammer to install plain bearings. Use a press only.

Carefully remove the PTO oil seal with a screwdriver, without damaging the PTO cover.

Press out the plain bearings from the outside towards the inside.

PLAIN BEARING TOOL	
PLAIN BEARING REMOVER / UNSTALLER	

The PTO cover has to be supported from below with suitable support with straight surface, in order to prevent damage of the sealing surface.

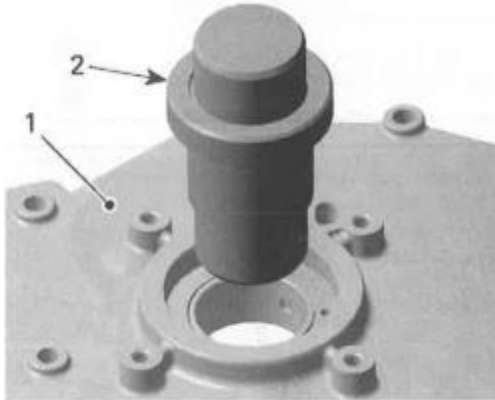

- 1. PTO cover
- 2. Plain bearing remover /installer

Plain Bearing Installation

NOTE: Do not lubricate plain bearings and/or PTO cover for installation.

Install plain bearings in a cool PTO cover.

PLAIN BEARING TOOL	
PLAIN BEARING REMOVER / UNSTALLER	

Mark position of oil bore on PTO cover and on plain bearing remover/installer. Align mark on plain bearing remover/installer with mark on PTO cover.

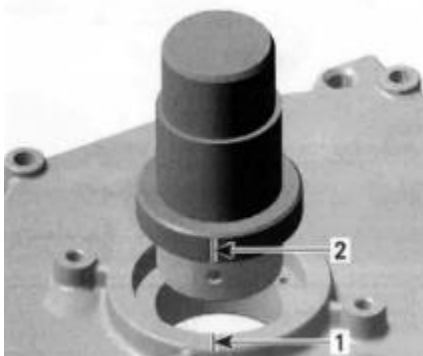

- 1. Mark position of oil bore on PTO cover
- 2. Mark position of oil bore on plain bearing remove/installer

Carefully press-in the plain bearings in the

same direction as during disassembly, from the outside towards the inside. Support PTO cover with suitable support with straight surface, in order to prevent damage of the sealing surface.

NOTE: Wrong oil bore position will stop oil supply to plain bearings and wil1 damage the engine.

The partition of the plain bearings must be positioned near to oil bore in counterclockwise direction.

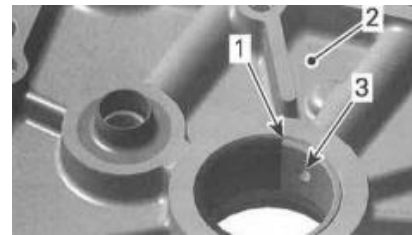

- 1. Partition
- 2. PTO cover (inside)
- 3. Oil bore

PTO Cover Installation

For installation, reverse the removal procedure.

Pay attention to the following details.

NOTE: At installation, replace PTO cover gasket and oil seal.

Tighten PTO cover screws following the illustrated sequence.

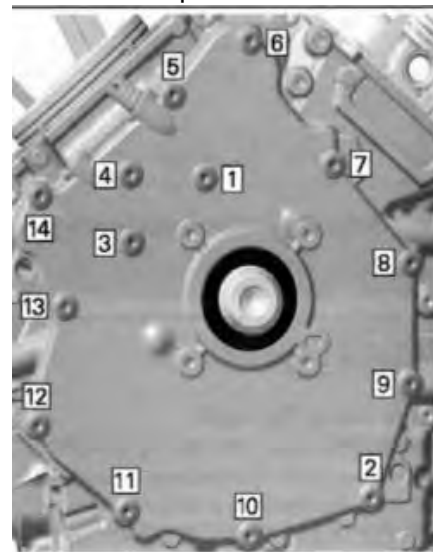

TIGHTENING SEQUENCE

PTO COVER SCREW	
Tightening sequence	10N·m ± 1 N·m (89lbf·in ± 9lbf·in)

DRIVEGEARS

Drive Gears Location

The engine is equipped with a breather gear which prevents engine oil coming out through the breathing system into the air intake system. The drive gears are located on the engine PTO side behind the PTO cover.

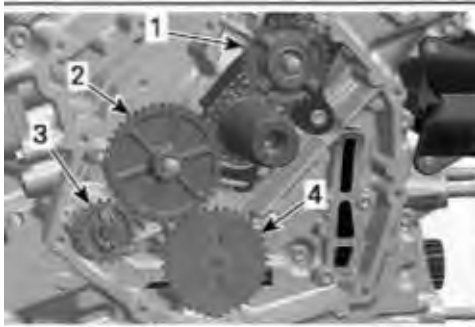

1. Breather gear
2. Intermediate gear
3. Water pump drive gear
4. Oil pump drive gear

Drive Gears Removal

Remove PTO cover (refer to PTO COVER). Withdraw intermediate gear and breather gear.

For oil pump drive gear removal, refer to OIL PUMP in the LUBRICATION SYSTEM subsection.

To remove water pump drive gear, pull the shaft assembly a bit out and turn it about one teeth until it stays out.

Then push water pump drive gear in.

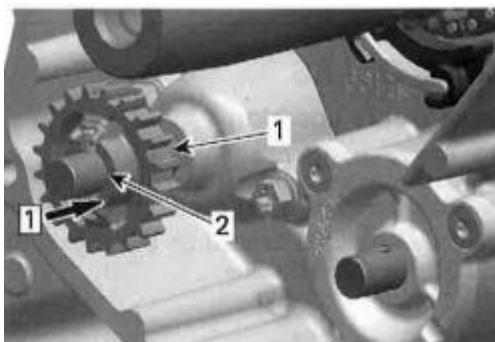

Step: Push gear in

1. Water pump drive gear
2. Intermediate shaft

Remove needle pin and pull water pump drive gear out.

Remove thrust washer from intermediate shaft.

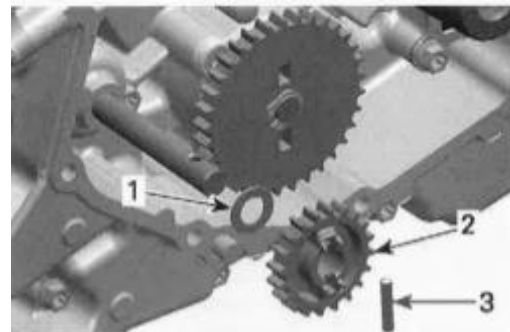

1. Thrust washer
2. Water pump drive gear
3. Needle pin

Drive Gears Inspection

Intermediate Gear/Oil Pump Drive Gear/Water Pump Drive Gear

Inspect gears for wear or other damage. Replace if damaged.

Breather Gear

Check if oil seal is brittle, hard or damaged. Replace if necessary.

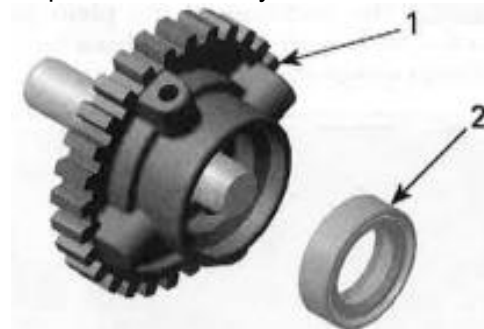

1. Breather gear
2. Oil seal

Inspect gear for wear or other damage.

Check ball bearing for excessive play and smooth operation. Replace breather gear assembly if necessary.

Drive Gears Installation

The installation is essentially the reverse of the removal procedure.

Adequately oil the ball bearing of the breather gear.

CRANK CASE

Crankcase Disassembly

1. Refer to PERIODIC MAINTENANCE PROCEDURES subsection and:
 - 1.1 Drain cooling system.
 - 1.2 Drain engine oil.
 - 1.3 Drain gearbox oil.
2. Lock crankshaft. Refer to CRANKSHAFT LICKING PROCEDURES in the this subsection.
3. Refer to COUNTINUOUSLY VARIABLE TRANSMISSION (CVT) subsection to remove following parts:
 - CVT cover
 - Drive pulley
 - Driven pulley
 - CVT air guide.
4. Remove engine from vehicle. Refer to ENGINE REMOVAL AND INSTALLATION subsection.
5. Detach gearbox from engine. Refer to GEARBOX AND 4×4 COUPLING UNIT .
6. Refer to MAGNETO SYSTEM subsection to remove the following parts:
 - Magneto cover
 - Rotor with sprag clutch gear
 - Starter drive gears.
7. Refer to following procedures in this subsection to remove the following parts:
 - PTO cover
 - Drive gears
 - Bearing covers of engine drive shaft.
8. Refer TIMING CHAIN subsection to remove following parts:
 - Chain tensioners
 - Camshaft timing gears
 - Timing chains
 - Timing chain guides.
9. Refer to TOP END subsection to remove following parts:
 - Front cylinder head
 - Rear cylinder head
 - Cylinders.

10. Refer to COOLING SYSTEM subsection to remove following parts:
- Water pump housing.

11. Refer to LUBRICATION SYSTEM subsection to remove following parts:

- Oil filter
- Oil cooler
- Oil pump drive gear.

NOTE: Oil pump removal from crankcase is not necessary, but recommended to see condition of oil pump (refer to LUBRICATION SYSTEM subsection).

12. Remove electric starter.

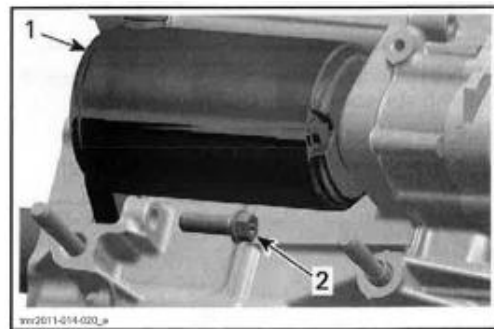

1. Electric starter
2. Screw

NOTE: Before splitting the crankcase, measure crankshaft axial play. Refer to CRANKSHAFT. Remove retaining screws of crankcase.

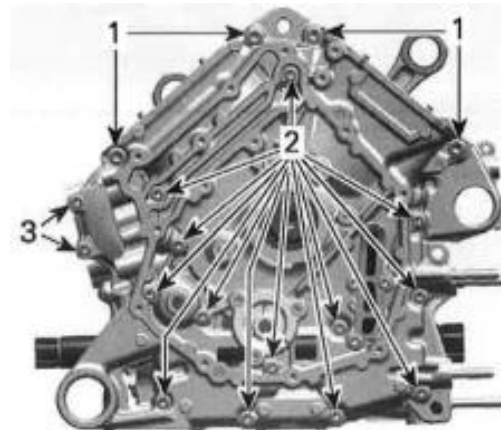

1. Four screws M8x65
2. 13 screws M16x75
3. Two screws M6x25

Carefully split crankcase halves by using a screwdriver and a soft hammer.

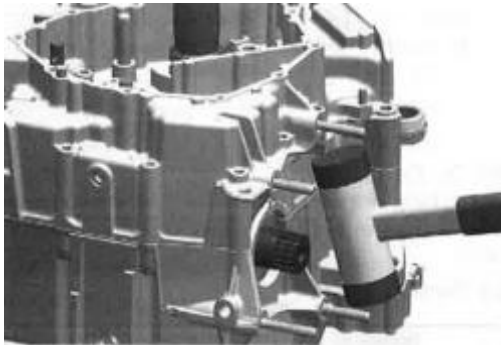

NOTE: During disassembly, do not damage the sealing surfaces of the crankcase halves.

Pull crankshaft out of crankcase.

Remove the water pump intermediate shaft.

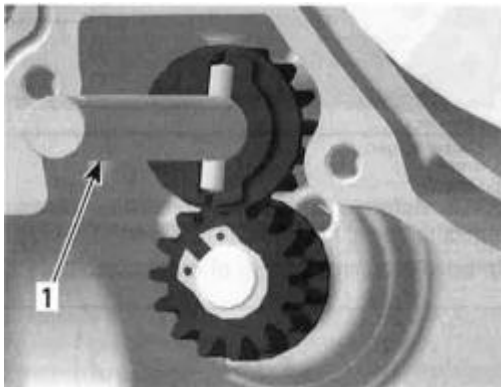

1. Water pump intermediate shaft

Remove engine oil strainer.

NOTE: Oil strainer removal for inspection and cleaning is recommended. Refer to LUBRICATION SYSTEM subsection.

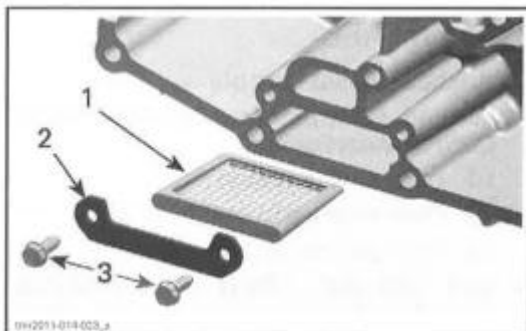

1. Engine oil strainer

2. Retaining plate

3. Screws

Crankcase Cleaning

△ WARNING

Use safety goggles to avoid eye injuries

Clean crankcase using a part cleaner.

Dry crankcase using compressed air .

Blow the oil supply lines.

Crankcase Inspection

Check crankcase halves for cracks or other damage. Replace if damaged.

Check MAG and PTO plain bearings in for scoring or other damages.

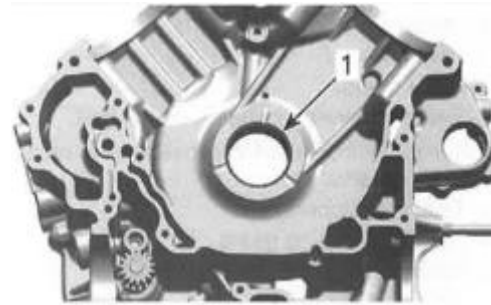

1. Plain bearing

NOTE: Measure plain bearing inside diameter and compare to PTO/MAG main journal diameters of crankshaft (refer to CRANKSHAFT).

Replace if the measurements are out of specification.

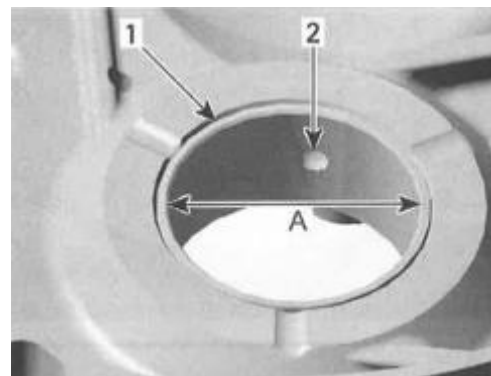

1. Plain Bearing

2. Oil bore

A. Measure plain bearing inside diameter



MAIN BEARING INSIDE DIAMETER(PTO/MAG)	
SERVICE LIMIT	42.100 mm(1.6575in)

Plain Bearing Replacement (Main)
Plain Bearing Removal

Always support crankcase halves properly when plain bearings are removed. Damages to crankcase halves may occur if this procedure is not performed correctly.

NOTE: Always use a press for removal of plain bearings.

Carefully press the plain bearings out, from the crankcase half inside towards the outside.

REQUIED TOOLS	
CRANKCASE SUPPORT MAG/PTO	
PLAIN BEARING REMOVER/INSTALLER	

NOTE: During disassembly, make sure not to damage the sealing surfaces of the crankcase halves.

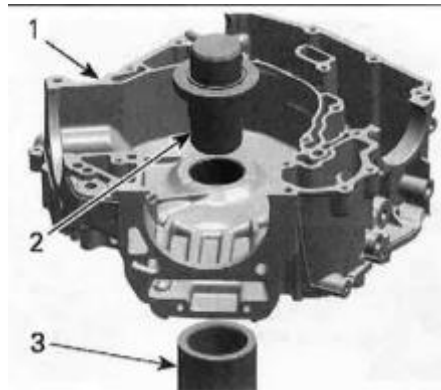

PUSH PLAIN BEARING OUTSIDE

1. Crankcase half
2. Plain bearing remover/installer
3. Crankcase support sleeve

Plain Bearing Installation (Main)

Unless otherwise instructed, never use hammer to install plain bearings. Use press only.

NOTE: Place the proper crankcase support sleeve under crankcase halves before installing the plain bearings (refer to BEARING REMOVAL PROCEDURE)

Carefully press in the plain bearings in the same direction as during disassembly, from the crankcase inside towards the outside. During reassembly, make sure not to damage the sealing surfaces of the crankcase halves.

Install plain bearings in a cold crankcase. **NOTE:** Do not lubricate plain bearings and/or crankcase for installation.

Use an O-ring ($\phi 42 \times 1\text{mm}$ to 1.5mm (.04 into .06 in) thickness) to hold plain bearings in place during installation. The O-ring will disappear in the groove of the plain bearing remover/installer.

Mark position of plain bearing oil bore on plain bearing remover/installer.

Mark position of oil bore on crankcase half. Align mark on plain bearing remover/installer with mark on crankcase half.

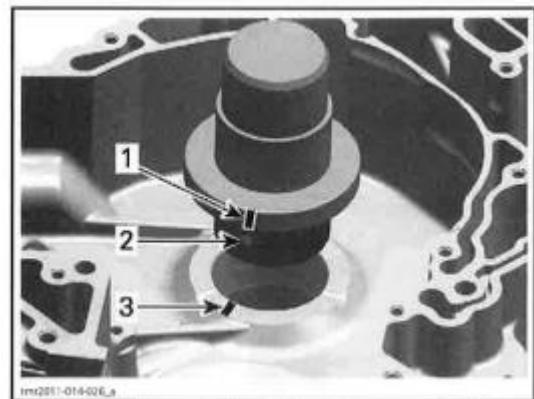

1. Oil bore position marked on plain bearing remover/installer
2. Plain bearing oil bore
3. Oil bore position marked on crankcase

Misalignment of the plain bearing and crankcase oil bores will prevent proper oil supply to plain bearings.

Carefully press in the plain bearings from inside the crankcase towards the outside.

The partition of the plain bearings in crankcase half MAG side must be positioned near to oil bore in clockwise direction.

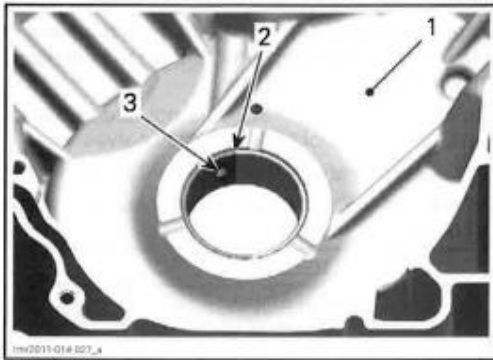

- 1. Crankcase half MAG (inside surface)
- 2. Partition
- 3. Oil bore

█ The partition of the plain bearings in crankcase half PTO side must be positioned near to oil bore in counterclockwise direction.
152

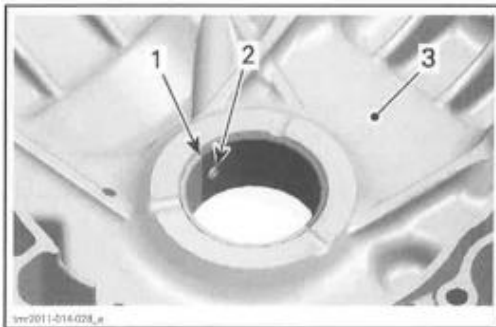

- 1. Partition
- 2. Oil bore
- 3. Crankcase half PTO (inside)

Crankcase Assembly

The assembly of crankcase is essentially the re-verse of removal procedure. However, pay attention to the following details.

Install a NEW crankcase gasket.

Oil the plain bearings before mounting the crank- shaft.

█ Correctly reinstall crankshaft (refer to CRANKSHAFT)

Properly reinstall engine oil strainer and screws. Refer to LIBRICATION SYSTEM subsection.

Reinstall water pump intermediate shaft and gears. Refer to WATER PUMP GEARS in the COOLING SYSTEM subsection.

Tightening sequence for screws on crankcase is as per following illustration.

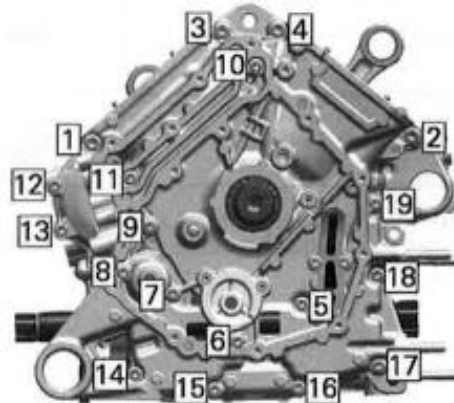

TIGHTENCE SEQUENCE

CRANKCASE SCREWS	
Tightening torque- M6	10N·m±1N·m (89lbf·in ± 9lbf·in)
Tightening torque- M8	25N·m±3N·m (18lbf·ft±2 lbf·ft)

CRANK SHAFT

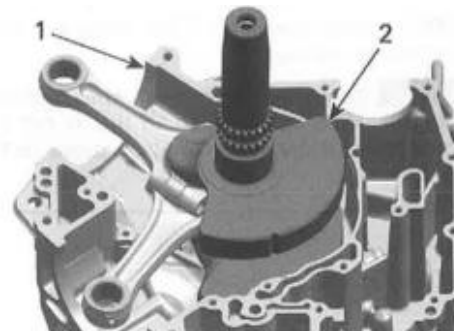

- 1. Crankcase MAG
- 2. Crankshaft

Crankshaft Locking Procedure

NOTE: When crankshaft is locked, the rear piston no. 2 is at TDC. Crankshaft can not be locked at piston no.1 TDC.

█ To see if the rear piston no. 2 is at TDC ignition refer to CRANKSHAFT TIMING GEAR in the TIMING CHAIN subsection.

Remove:

- 1. Spark plug cables and spark plugs of both cylinders.
- 2. Plug screw and O-ring of magneto cover.

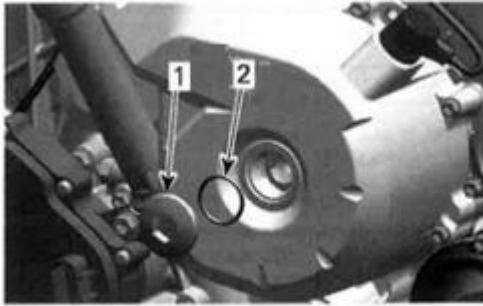

- 1. Plug screw
- 2. O-ring

3. Crankshaft position sensor.

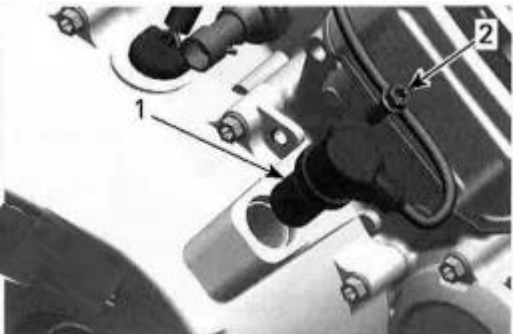

- 1. Crankshaft position sensor
- 2. Screw

4. Plug screw and discard sealing ring

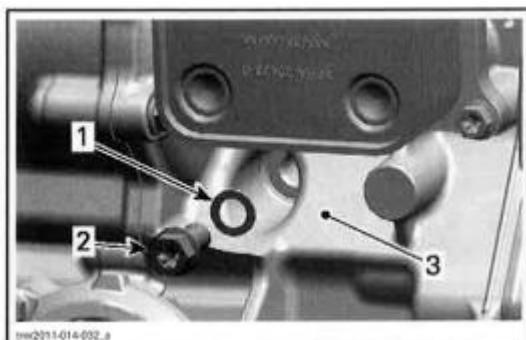

- 1. Sealing ring
- 2. Plug screw
- 3. Crankcase PTO side, front side

Use a 14 mm Allen key to turn crankshaft until piston no. 2 is at TDC.



- 1. Allen key 14 mm

When rear piston is at TDC marks on magneto flywheel "2" and on the magneto cover are aligned .

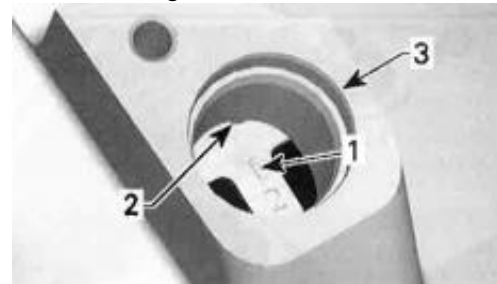

- 1. Mark "2" on magneto flywheel
- 2. Notch on magneto cover
- 3. Crankshaft position sensor location

Use a screwdriver to check if the groove in the crankshaft is aligned with the hole.



- 1. Screw driver

Lock crankshaft

REQUIRED TOOL	
CRANKSHAFT LOCKING	



- 1. Crankshaft locking bolt

Gradually insert the tool in the crankshaft groove. Make sure that the tool tip enters the groove and does not jam on the crankshaft balancer surface.

Crankshaft Removal

Refer to CRANKCASE

Crankshaft Inspection

NOTE: Check each bearing journal of crankshaft for scoring, scuffing, cracks or other signs of wear. NOTE: Replace crankshaft if the gears are worn or otherwise damaged.

Components out of specifications always have to be replaced .If this is not observed, severe damage may be caused to the engine.

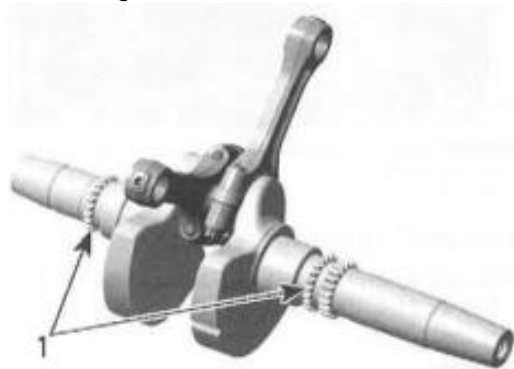

1. Crankshaft timing gears

Crankshaft Axial Play

NOTE: Axial play needs to be measured before splitting the crankcase.

Measure play on PTO end, using a dial indicator.

Crankshaft Axial Play	
NEW	0.200 mm to 0.500 mm (.008in to.02in)
SERVICE LIMIT	0.600 mm(.024in)

If play is out of specification, replace crankcase and/or crankshaft.

Connecting Rod Big End Axial Play

Using a feeler gauge, measure distance between butting face of connecting rods and crankshaft counterweight . If the distance exceeds specified tolerance, replace the crankshaft.

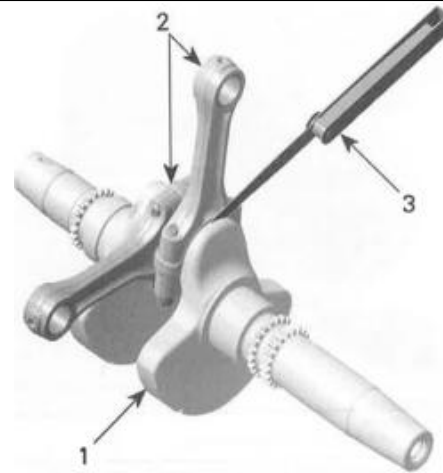

1. Crank shaft
2. Connecting rods
3. Feeler gauge

CONNECTING ROD BIG END AXIAL PLAY		
ENGINE	NEW	0.250 mm to 0.550 mm (.01 in to.022in)
	SERVICE LIMIT	0.600 mm(.024in)

Connecting Rod/Piston Pin Clearance

Refer to TOP END section.

Connecting Rod Big End Radial Play

NOTE: prior to remove connecting rod from the crankshaft, mark big end halves together to ensure a correct reinstallation (cracked surface fits in only one position). Remove connecting rods from crankshaft.

Connecting rod screws are not reusable. Always discard screws and replace by NEW ones. It is recommended to install new plain bearings when reinstalling connecting rods.



1. Connecting rod screws

Measure crankpin . Compare to inside diameter of connecting rod big end.

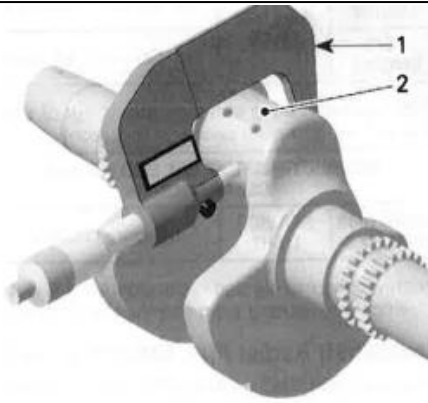

- 1. Micrometer
- 2. Crankpin area for plain bearing

CRANK PIN DIAMETER		
ENGINE	NEW	41 .986 mm To 42.010 mm (1 653in to1.6539in)
	SERVICE LIMIT	41. 967mm (1 6522 in)

If the crank pin diameter is out of specification, replace crankshaft.

To measure the connecting rod big end diameter, use the OLD connecting rod screws.

Install the OLD plain bearings as they were mounted initially.

Carry out the tightening procedure described in CRANKSHAFT ASSEMBLY in this subsection.

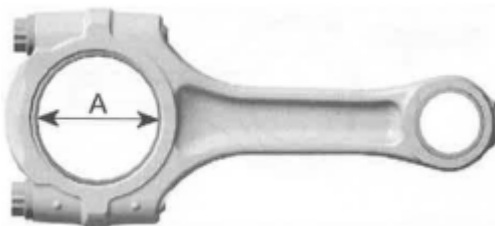

A. Connecting rod, big end plain bearing

CONNECTING ROD BIG END RADIAL		
ENGINES	SERVICE LIMIT	42.100mm (1.6575in)

If connecting rod big end diameter is out of specification, replace plain bearings and recheck.

CONNECTING ROD BIG END RADIAL		
ENGINES	SERVICE LIMIT	0.09mm (.0035in)

If connecting rod big end radial clearance is out of specification, replace plain bearings and recheck.

Crankshaft Radial Play MAG/PTO Side

Measure crankshaft on MAG/PTO side . Compare to inside diameter of MAG/PTO plain bearing (refer to CRANKCASE).

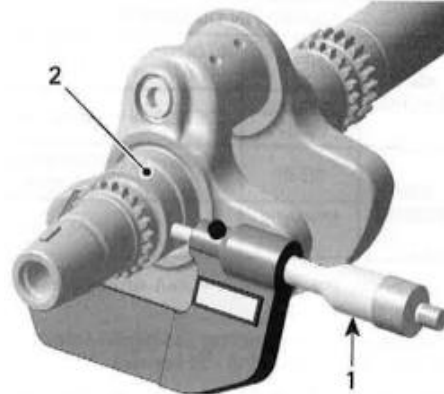

- 1. Micrometer
- 2. Crankshaft area for MAG plain bearing

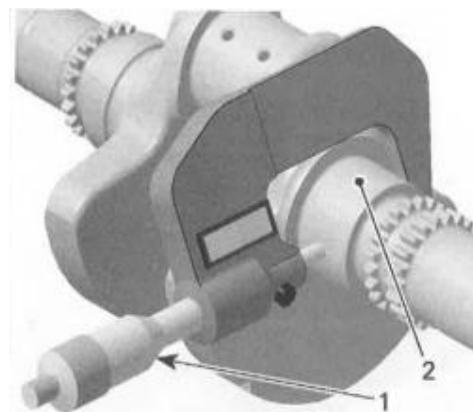

- 1. Micrometer
- 2. Crankshaft area for PTO plain bearing

CRANKSHAFT MAIN BEARING JOURNAL DIAMETER (MAG/PTO SIDE)	
NEW	42.016mm to42.040mm (1.6542in to1.6551 in)
SERVICE LIMIT	42.000mm(1.6535in)
CRANKSHAFT RADIAL PLAY (MAG/PTO SIDE)	
SERVICE LIMIT	0.07 mm(.0028in)

Crankshaft Radial Play (PTO Cover Bearing)

Measure crankshaft journal diameter (PTO cover bearing) . Compare to plain bearing inside diameter (PTO cover). Refer to PTO COVER in this subsection.

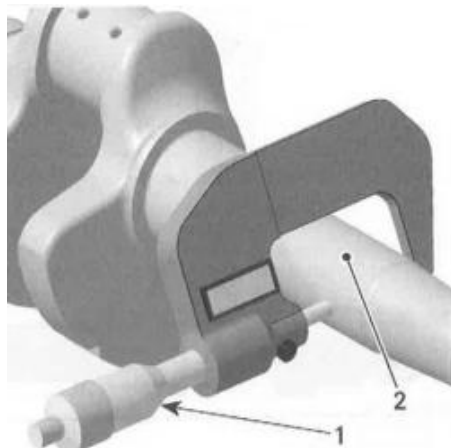

1. Micrometer
2. Crankshaft journal (PTO support bearing)

CRANKSHAFT JOURNAL DIAMETER (PTO COVER BEARING)	
NEW	34.004mm to 34.020 mm (1.3387In to 1.3394in)
SERVICE LIMIT	33.998 mm(1.3385in)

CRANKSHAFT RADIAL PLAY (PTO COVER BEARING)	
SERVICE LIMIT	0.10 mm(.0039 in)

If crankshaft journal diameter is out of specification, replace crankshaft.

If crankshaft radial play (PTO cover bearing) out of specification, replace plain bearings and recheck.

Crankshaft Assembly

For assembly, reverse the disassembly procedure. Pay attention to following details. Clean the split surface on both sides (cracked area) carefully with compressed air. Put plain bearings correctly in place.

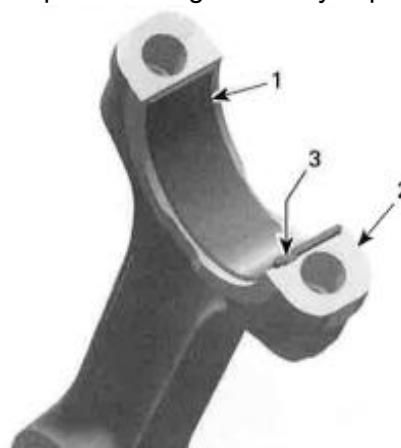

1. Half plain bearing of connecting rod big end
2. Split surface of the connecting rod
3. Nose of plain bearing in line with connecting rod groove

Oil the plain bearing surface of the connecting rod and crank pin before installation.

Lower cap and rod must match together since there is a cracked surface.

Oil NEW connecting rod screws

Always use NEW connecting rod screws at final assembly. They are not reusable.

Thread screws in the connecting rods, then tighten as per following procedure.

Strictly adhere following instructions:

- Do not apply any thread locker.
 - The running direction of the big end bearings and of the piston pins must not change.
 - Always perform each step on both connecting rod
- Failure to strictly follow procedure may cause connecting rod screws to loosen and lead to Severe engine damage.

REQUODE TOOLS	
	Torque wrench
	Angle torque wrench

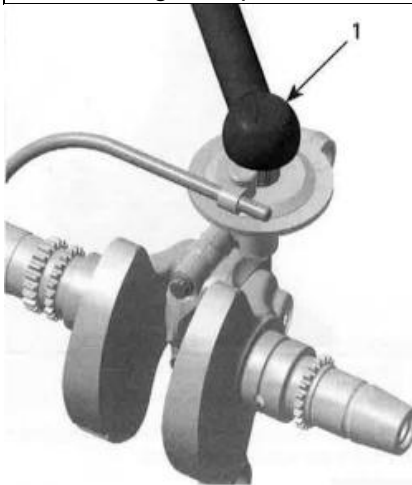

1. Angle torque wrench

Connecting rods are asymmetric. There must be no gap between the small ends when they face each other.

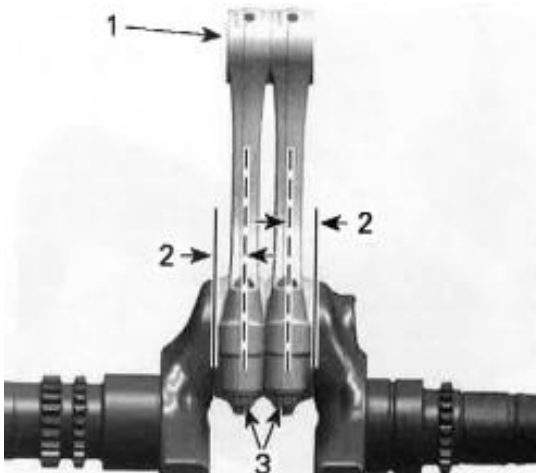

1. Connecting rod small ends
2. Connecting rod offset
3. Connecting rod screws

CONNECTING RODS SCREWS TIGHTENING SEQUENCE	
1	Tighten to 1/2 of specified torque
2	Tighten to $30\text{N}\cdot\text{m} \pm 2\text{N}\cdot\text{m}$ ($22\text{lb}\cdot\text{ft} \pm 1\text{lb}\cdot\text{ft}$)
3	Torque by an additional $90 \pm 5^\circ$ turn using an angle torque wrench

Crankshaft Installation

For installation of crankshaft in crankcase reverse the removal procedure. Pay attention to the following details.

Do not mix up the connecting rods of cylinders 1 and 2 during installation.

Observe the correct installation position when fitting the crankshaft with the connecting rods. The connecting rod MAG side has to face cylinder no. 1.

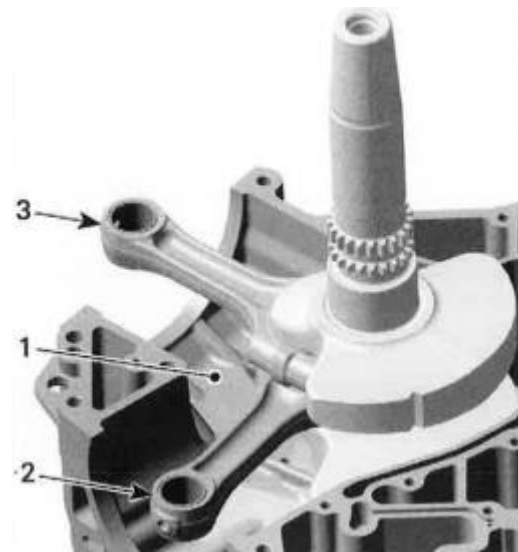

1. Crankcase half MAG side
2. Connecting rod cylinder 1
3. Connecting rod cylinder 2

CONTINUOUSLY VARIABLE TRANSMISSION (CVT)

Never touch CVT while engine is running.

never drive vehicle when CTV cover is removed.

Subcomponent installation and assembly tolerances require strict adherence to procedures detailed.

Never use any type of impact wrench at drive pulley removal and installation.

The clutch assembly is a precisely balanced unit. Never replace parts with used parts from another clutch assembly

These pulleys have metric threads. Do not SAE threads puller. Always tighten puller by hand to ensure that the drive pulley has the same type of threads prior to fully tightening.

DRIVE BELT

Removal

Remove:

- Distance screws
- remove CVT cover and gasket.

1. CVT cover
2. Distance screw
3. Gasket

NOTE:

Remove the center top screw last. This screw allows to support the cover during removal.

Open driven pulley with the driven pulley expander.

Screw tool in the threaded hole of driven pulley and tighten to open the pulley.

1. Driven pulley expander
2. Fixed sheave of driven pulley

To remove belt, slip the belt over the edge of fixed sheave as shown.

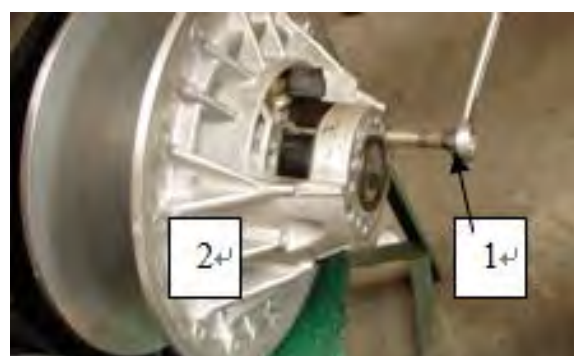

INSPECTION

Inspect belt for cracks, fraying or abnormal wear. Replace if necessary.

Drive belt width	
Service limit	30.00mm(1.181 in)

Installation

For installation, reverse the removal procedure. Pay attention to following details.

1. Word printed on belt
2. Drive pulley (front)
3. Driven pulley (rear)
4. Rotation direction

The maximum drive belt life span is obtained when the drive belt has the proper rotation direction. Install it so that the arrow printed on belt is pointing towards front of the vehicle, viewed from top.

Install CVT cover gasket.

Install the center top screw in first.

Tighten the distance screw as per following sequence.

DRIVE PULLEY

1. Belt
2. Drive pulley(front)
3. Driven pulley(rear)

Removal

- remove CVT cover and gasket.
- Remove belt

Block the drive pulley as followed.

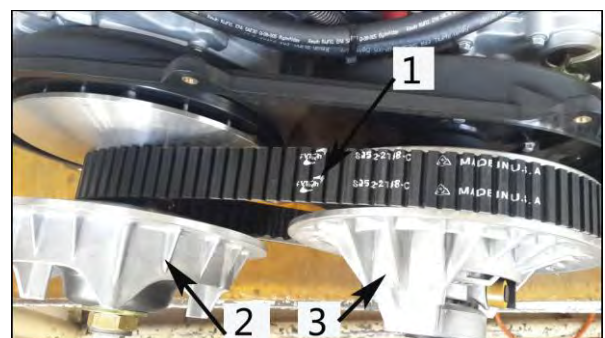
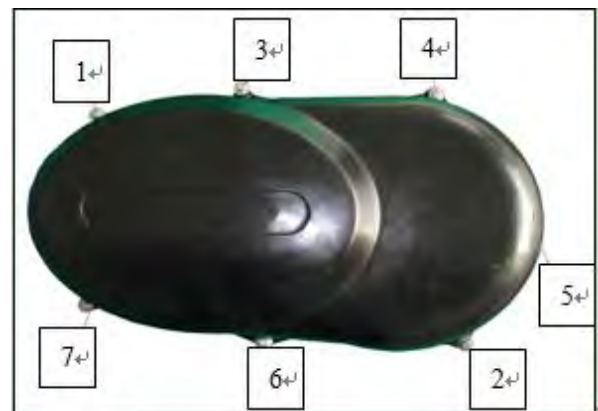
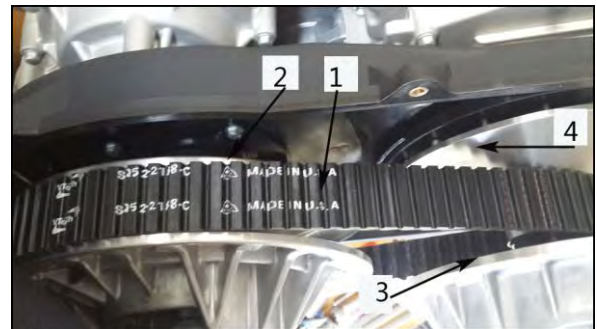

Block drive pulley with the pulley holding tool.

1. Pulley holding tool
2. Torque wrench



When the drive pulley is blocked, mark sliding sheave and governor cup to ensure correct reinstallation.

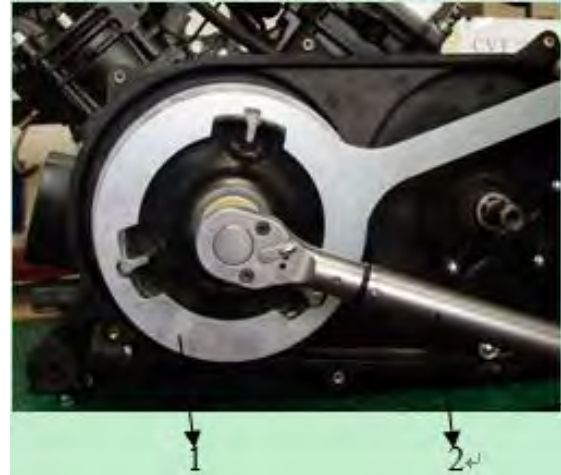

Unscrew the drive pulley screw (right hand thread), then remove it as well as the conical spring washer and thrust washer.

1. Drive pulley
2. Thrust washer
3. Drive pulley screw



Inspection

Drive pulley should be inspected annually for wear or damages.

Check drive pulley for cracks and sliding contact surface for excessive wear. Replace it if necessary.

Check one-way clutch bearing for excessive play and smooth operation. Replace one-way clutch if necessary.

Installation

For installation, reverse the removal procedure. Pay attention to the following details.

Do not apply any lubricant on crankshaft and drive pulley tapers.

Clean pulley faces and shaft with dry cloth.

Install drive pulley on crankshaft extension.

Do not forget to place thrust washer

Never substitute conical spring washer and/ or screw with jobber ones. Always use genuine parts for this particular case.

Install thrust washer with its concave side towards drive pulley then install drive pulley screw.

To torque the drive pulley screw, block the drive pulley. Refer at the beginning of this section.

When the drive pulley is blocked, torque screw to 100N.m.

DRIVEN PULLEY

- Removal
- remove CVT cover and gasket.
- Remove belt

Using the pulley holding tool, hold the driven pulley during the removal of the driven pulley screw, do not remove screw completely.



Put in tow STUD to Driven Pulley

1. Driven Pulley holding tool
2. Torque wrench

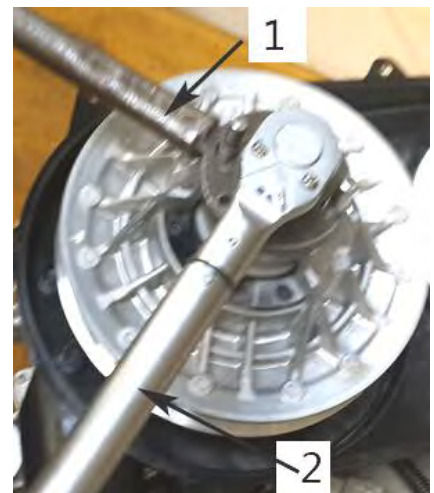

When the driven pulley is blocked, unscrew the driven pulley screw.

1. Driven pulley
2. Thrust washer
3. Driven pulley screw



Inspection

Driven pulley should be inspected annually for wear or damages.

Check sliding and fixed sheave for cracks and sliding contact surface for excessive wear.

Replace sliding sheave if necessary.

Check sliding sheave bushings for cracks, scratch and for free movement when assembled to sliding sheave.

Check ball bearing for free play and smooth operation. Replace if necessary.

Installation

For installation, reverse the removal procedure. Pay attention to the following details.

Chamfer on inside diameter of the spacer must face engine side.

Clean pulley faces and shaft with dry cloth.

Driven pulley is a spring loaded system.

Always place washer at the time of driven pulley installation.

When the driven pulley is blocked, torque screw to 60N.m.

CVT AIR GUIDE**Removal**

Remove:

- CVT cover
- Drive belt
- Drive pulley
- Driven pulley

Unscrew the clamps retaining the CVT air hoses

Remove CVT air guide.

Inspection

Clean CVT air guide from contamination.

Check O-rings if brittle, hard or damaged.

Replace if necessary.

1. CVT air guide
2. O-rings

**Installation**

For installation, reverse the removal procedure.

GEARBOX

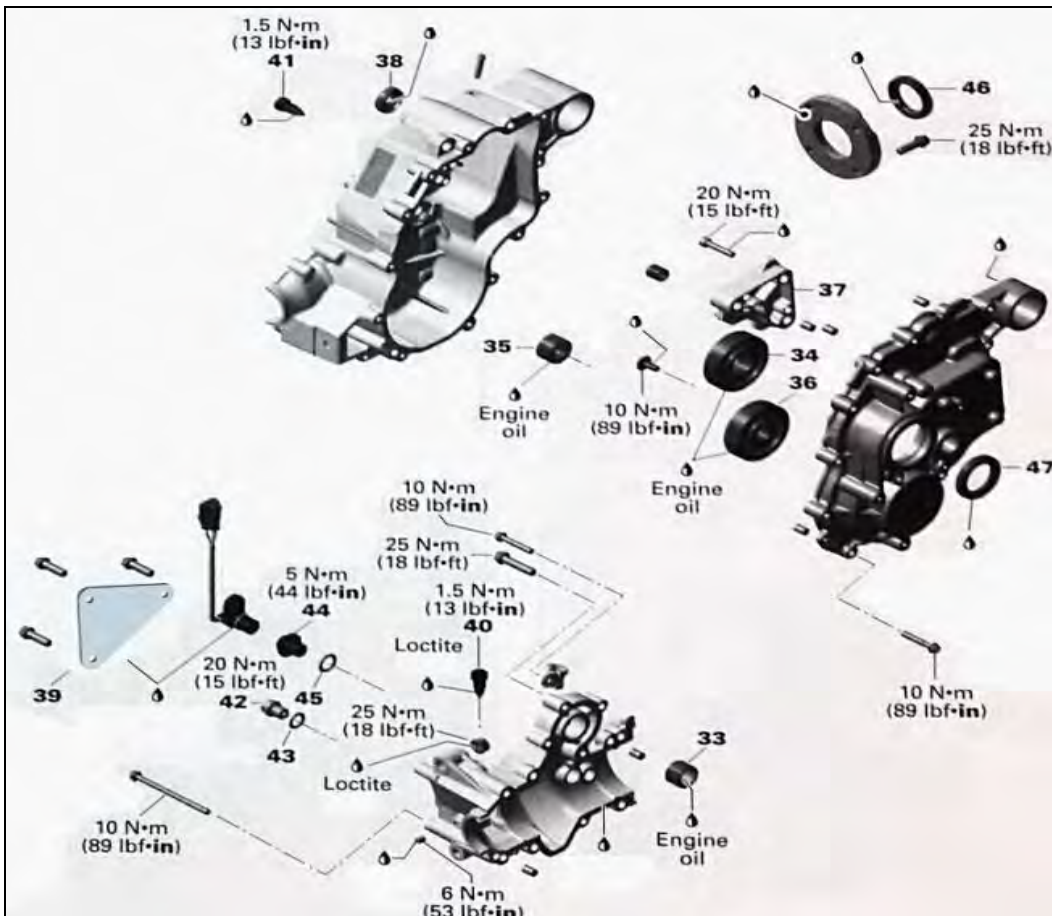
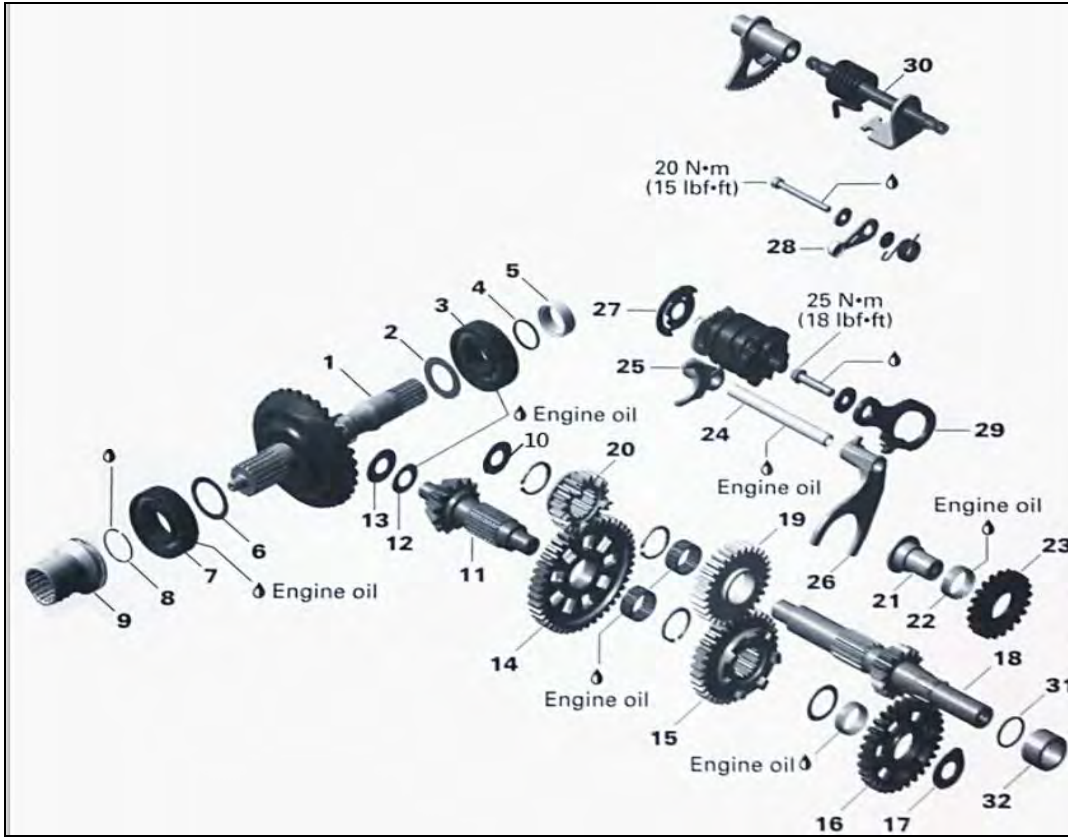

GENEAL

Gearbox Removal

Remove engine from vehicle. Refer to ENGINE REMOVAL AND INSTALLATUON for the procedure.

Refer to COUNTINUOUSLY VARIABLE TRANSMISSION (CVT) subsection to remove following parts:

- CVT cover
- Drive and driven pulleys
- CVT air guide.

Drain gearbox. Refer to GEARBOX OIL REPLACEMENT in PERIODIC MAINTNEANCE PROCDURES subsection.

Remove ACTIATOR see procedure in this subsection.

Unscrew the four (4) nuts that attach the gearbox to the engine.

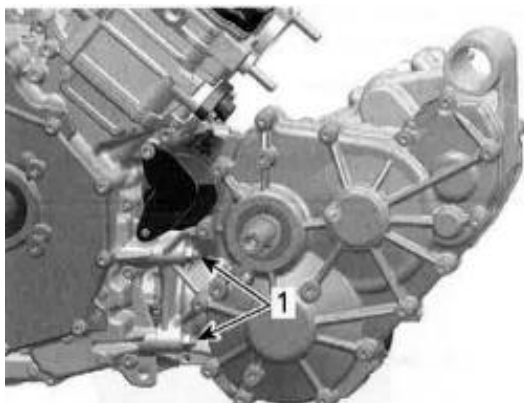

LH SIDE OF ENGINE

1. Nut M8
- 2.



RH SIDE OF ENGINE

1. Nut M8

Pull gearbox to separate it from engine.

Gearbox Disassembly

NOTE: During gearbox disassembly, inspect the condition of each part closely.

Gearbox Left Cover

Set gearbox to NEUTRAL position.

Unscrew all bolts retaining the gearbox left cover.

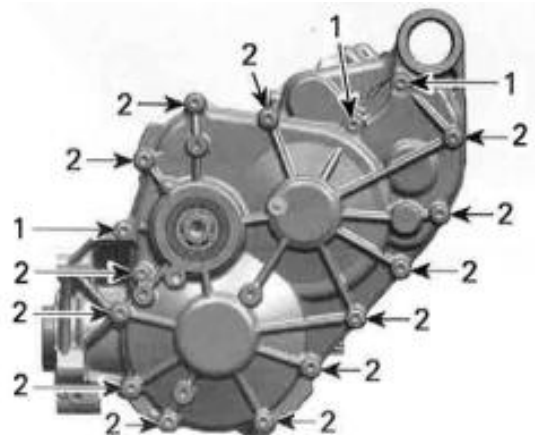

1. 3 screws M6x35
2. 13 screws M6x55

Place the center housing on a wood stand, left cover pointing upwards.

Using a big flat screwdriver and a soft hammer to lift the left cover .



POSITION FOR SOFT HAMMER



POSITION FOR BIG FLAT SCREWDRIVER

Index Lever and Index Washer

Set gearbox to NEUTRAL position.

Remove screw retaining the index washer to the shift drum.

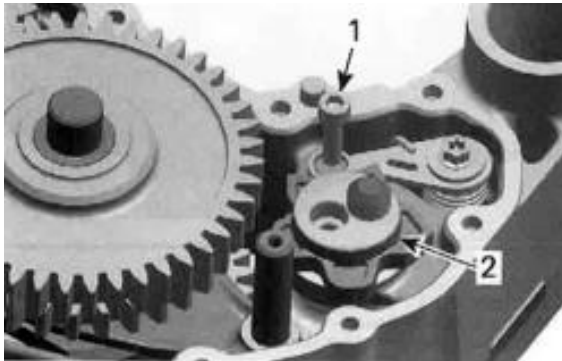

1. Screw
2. Index washer

Insert a flat screwdriver in the slot of index lever.

Turn screwdriver clockwise and remove index washer.



1. Index lever
2. Index washer
3. Shaft drum

Remove the index lever with washer, step ring and spring.



1. Washer
2. Index lever
3. Step ring
4. Index spring

Main Shaft and Shift Forks

Remove bearing pin, reverse intermediate gear and thrust washers.

NOTE: Take care not to lose lower thrust washer during removal.

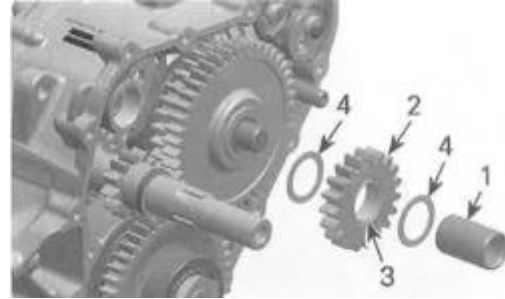

1. Bearing pin
2. Reverse intermediate gear
3. Needle bearing
4. Thrust washers

Remove shift fork shaft.

Disengage shift forks from shift drum



1. Shaft fork shaft
2. Shaft fork
3. Shaft drum

Remove main shaft assembly with shift fork.



1. Main shaft assembly
2. Shift fork

Remove shifting sleeve (HIGH range gear) and shift fork.

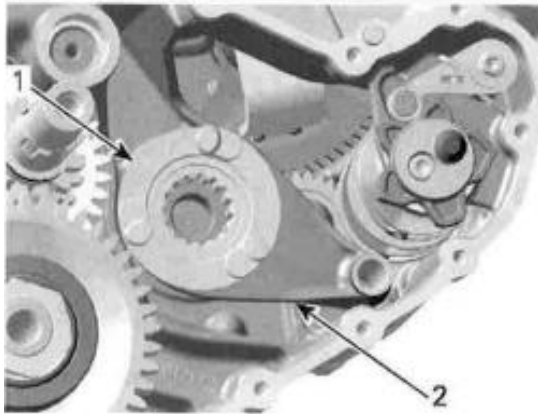

1. Shifting sleeve (HIGH range gear)
2. Shift fork

When required, remove from main shaft assembly:

- Snap ring (discard)
- HIGH range gear
- LOW range gear
- Needle bearings.

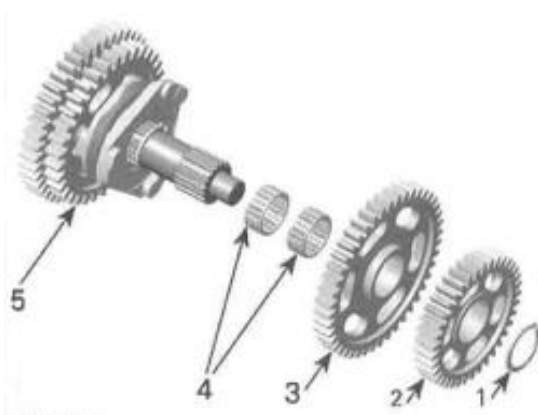

1. Snap ring
2. Free pinion (HIGH range gear)
3. Free pinion (LOW range gear)
4. Needle bearings
5. Main shaft assembly

Remove from main shaft assembly:

- Snap ring (discard)
- Shifting sleeve (LOW/REVERSE range gear) - Snap ring (discard)
- REVERSE range gear
- Needle bearing.

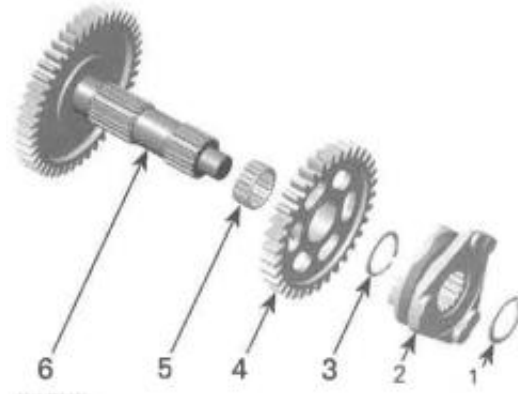

1. Snap ring
2. Shifting sleeve (LOW/REVERSE range gear)
3. Snap ring
4. Free pinion (REVERSE range gear)
5. Needle bearing
6. Main shaft assembly

Gearbox Right Cover

Remove ACTUATOR and GBPS (GEARBOX POSITION SENSOR) see procedures in this subsection.

Unscrew all bolts retaining the gearbox right cover.

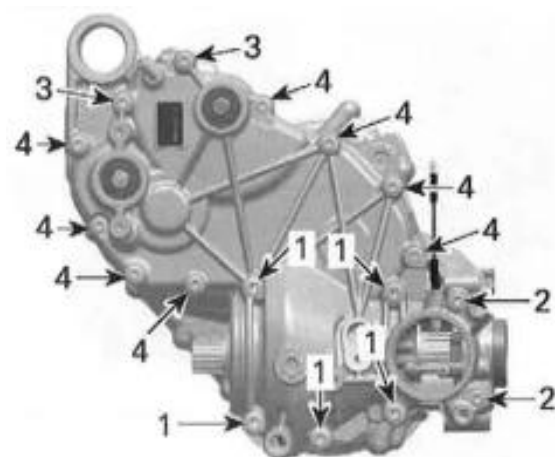

1. 5 Screws M8x55
2. 2 Screws M6x85
3. 2 Screws M6x55
4. 8 Screws M6x35

To remove cover, use 2 big screwdrivers

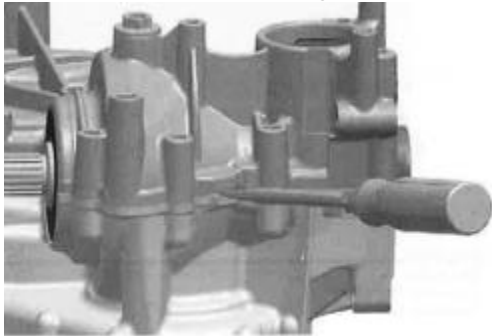

POSITION FOR BIG FLAT SCREWDRIVER

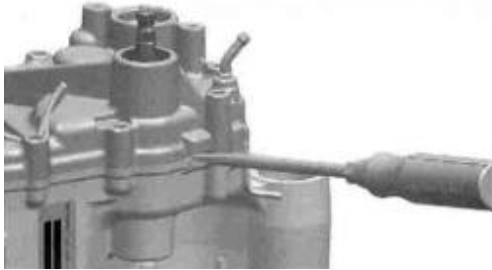

POSITION FOR BIG FLAT SCREWDRIVER

Shift Shaft and Shift Drum
Withdraw shift shaft assembly.

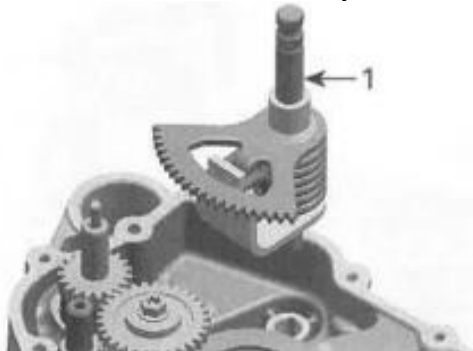

1. Shift shaft assembly

Remove screw retaining the shifting intermediate gear.

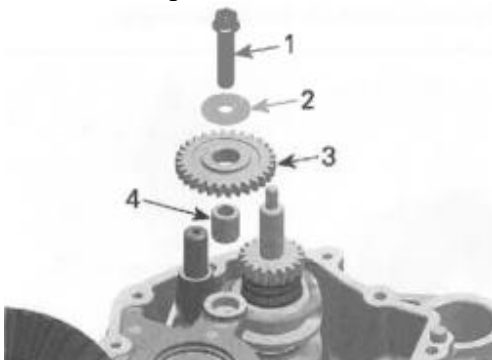

1. Screw
2. Washer
3. Intermediate gear
4. Dowel pin

Remove shift fork shaft.
Disengage shift forks from shift drum.

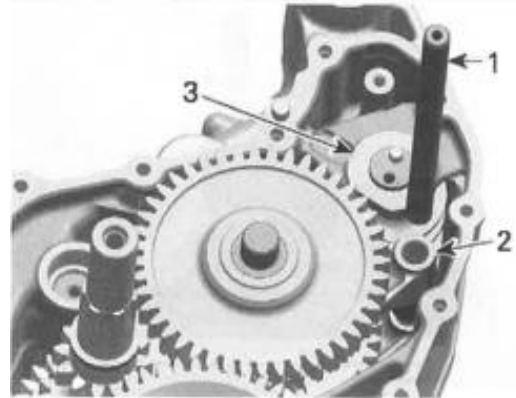

1. Shift fork shaft
2. Shift fork
3. Shift drum

Remove shift drum and thrust washer.

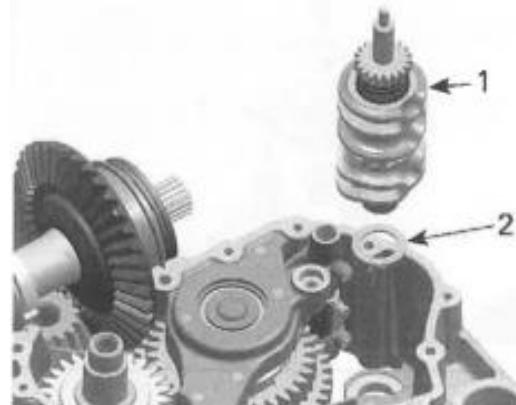

1. Shift drum
2. Thrust washer

Output Shaft and 4x4 Coupling Mechanism

Remove output shaft from center housing and withdraw 4x4 coupling sleeve.

Use a soft hammer to remove output shaft.



1. Output shaft
2. 4x4 coupling sleeve
3. Soft hammer

Remove set screw, coupling fork shaft and coupling fork from right cover.

△ WARNING
Clean oil, outside and inside, from housing before heating.

REQUIED TOOL	
BLIND HILE BEARING	

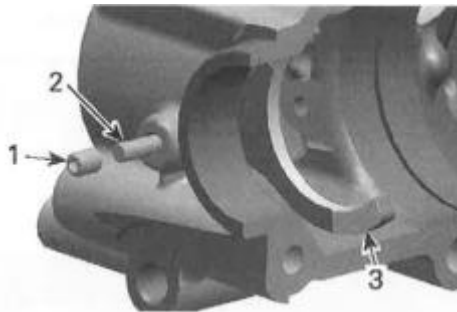

1. Set screw
2. Coupling fork shaft
3. Coupling fork

Counter shaft

Use a soft hammer to push out counter shaft from gearbox CVT side. Remove distance sleeve and O-ring.

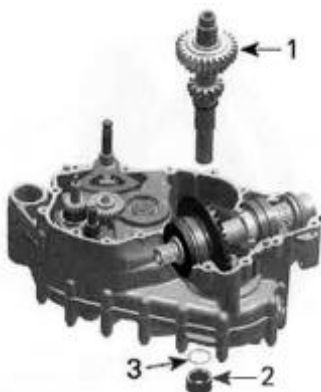

1. Counter shaft
2. Distance sleeve
3. O-ring

Gearbox Bearings

If necessary heat housing up to 100°C(212°F) before removing ball bearings.

Always support gearbox housings properly when ball bearings are removed. Housing damages may occur if this procedure is not performed correctly. To remove ball bearings of counter shaft (right cover) and main shaft (left cover) use following tool .

For ball bearings of counter shaft (1left cover) and main shaft (center housing) push with a suitable puller from outside in .

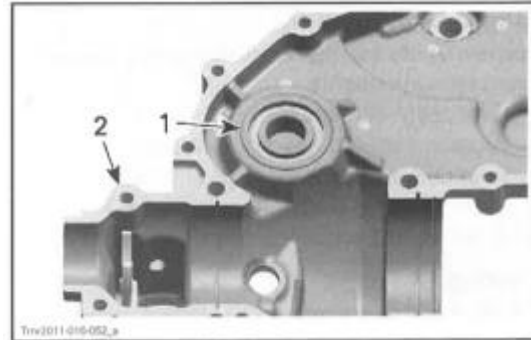

1. Ball bearing counter shaft
2. Right cover

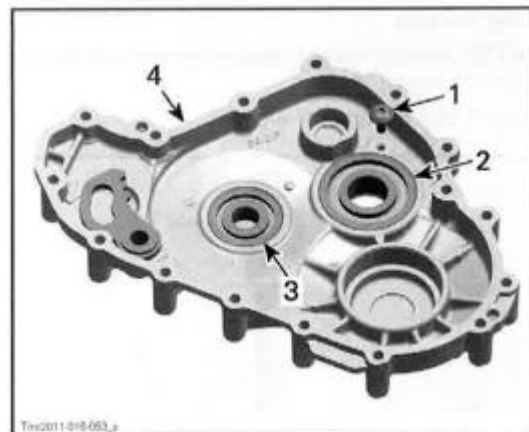

1. Screw
2. Ball bearing counter shaft
3. Ball bearing main shaft
4. Left cover



1. Ball bearing main shaft
2. Center housing

Gearbox Inspection

Always verify for the following when inspecting gearbox components:

- Gear teeth damage
- Worn or scoured bearing surfaces
- Rounded engagement dogs and slots
- Worn shift fork engagement groove
- Worn splines on shafts and shifting sleeves.

Bearings

Check if ball bearings turn freely and smoothly.

Check all bearings, bearing points, tooth flanks and taper grooves.

Free Pinions

NOTE: Always replace snap rings and use special pliers to install them.

Check free pinions for wear.

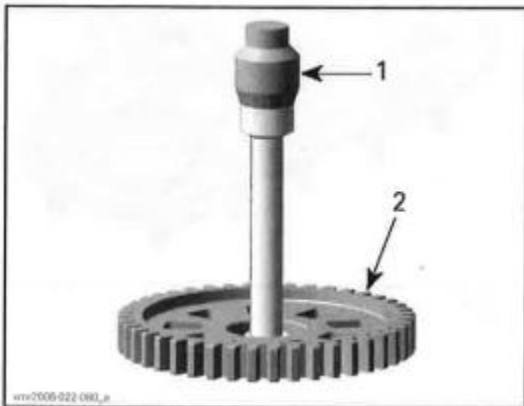

TYPICAL
1. Micrometer
2. Free pinion

DIAMETER FREE PINION	
NEW	29.000 mm to 29.013mm (1.1417in to 1.1422in)
SERVICE LIMIT	29.015mm(1.1423in)

Shifting Sleeves

Check shifting sleeves for worn inner splines and rounded or damaged engagement dogs.

BEARING PIN OUTER DIAMETER	
NEW	24.987mm to 25.000mm (.984in to .984in)
SERVICE LIMIT	24.977 mm(.9833 in)

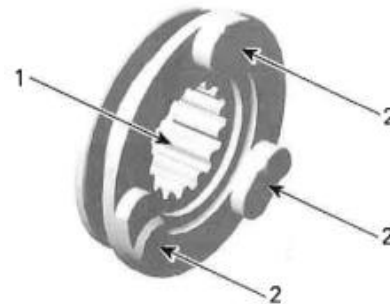

TYPICAL
1. Inner splines
2. Engagement dogs

Measure the width of shift fork engagement groove.

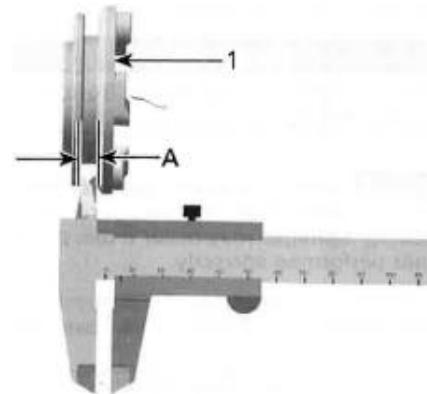

TYPICAL
1. Shifting sleeve
A. Width of shift fork engagement groove

WIDTH OF SHIFT FORK ENGAGEMENT GROOVE	
NEW	5.30 mm to 5.40 mm (.209in to .213in)
SERVICE LIMIT	5.50mm(.217in)

Shafts

Check bearing pin of reverse intermediate gear for wear.

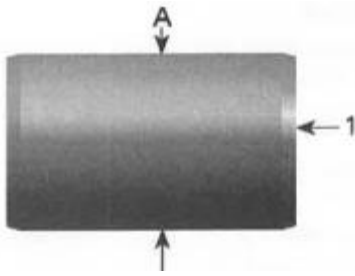

- 1. Bearing pin
- A. Outer diameter

Check counter shaft bearing journals for wear.

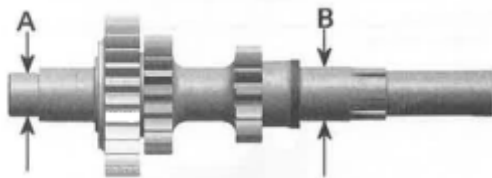

- A. MAG side
- B. Bearing journal CVT side

COUNTERSHAFT BEARING JOURNALS	
MAG SIDE	
NEW	19.977 mm to 19.990 mm (.786in to .787in)
SERVICE LIMIT	19.973 mm (.786in)
CVT SIDE	
NEW	24.977mm to 24.990mm (.983in to .984in)
SERVICE LIMIT	24.970 mm (.983 in)

Check main shaft for wear

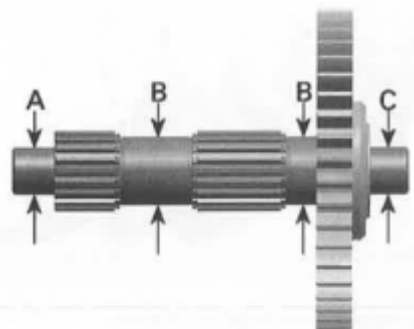

- A. Bearing journal MAG side
- B. Free pinion bearing
- C. Bearing journal CVT side

Shift Shaft

Check shift shaft for worn splines and gears. Check shift shaft spring for damages.

Shift Drum

Do not disassemble shift drum. Check if shifting gates move easily on shift drum splines and check condition of springs. Check shift drum tracks for scouring or heavy wear, like rounded engagement slots.

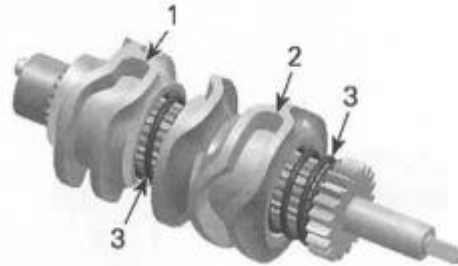

- 1. Track for the low/reverse range gear shift fork
- 2. Track for the high range gear shift fork
- 3. Springs

Shift Forks

Check both shift forks for visible damage, wear or bent shift fork claws. Check engagement rollers for wear and smooth movement. Measure the shift fork claw thickness.

MAIN SHAFT	
FREE PINION BEARING	
NEW	24.987mm to 25.000 mm (.984in to .984in)
SERVICE LIMIT	24.984 mm (.984 in)
BEARING JOURNAL CVT/MAG SIDE	
NEW	16.980mm to 16.991 mm (.669in to .669in)
SERVICE LIMIT	16.976mm (.668in)

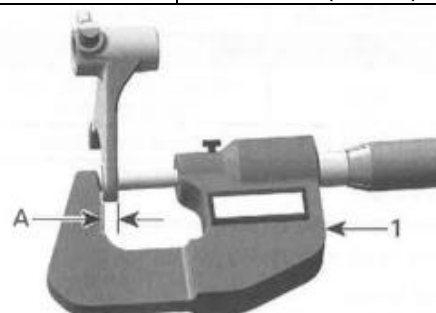

- 1. Micrometer
- A. Shift fork claw thickness

SHIFT FORK CLAW THICKNESS	
NEW	5.10 mm to 5.20 mm (.201 in to .205 in)
SERVICE LIMIT	5.00 mm (.197 in)

Shift Fork Shaft

Check shift fork shaft for visible damage or wear.

Check if shift fork shaft is straight.

Index Lever and Parking Lever

Index lever with roller must move freely.

Check parking lever for cracks or other damages.

Output Shaft

Check output shaft and its gear for cracks, bend, pitting or other visible damages.

Check output shaft splines for wear or other damages.

Check if the output shaft bearings turn freely and smoothly.

Replace oil seal if brittle, hard or damaged.

4x4 Coupling Sleeve



Check splines of coupling sleeve for wear or other damages.

1. Inspect splines

Measure the coupling sleeve groove width

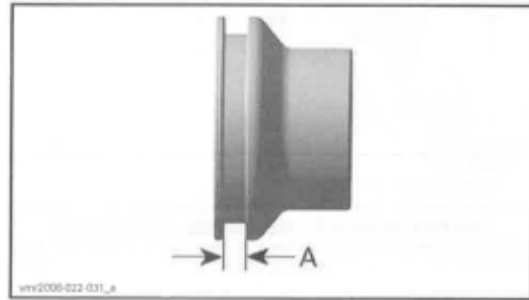

A. Groove width

COUPLING SLEEVE GROOVE WIDTH	
NEW	5.25mm to 5.35mm (.207 in to .211 in)
SERVICE LIMIT	5.50mm (.217 in)

Coupling Fork

Check coupling fork for visible damage, wear or bent coupling fork claws.

Check coupling fork claw thickness.

ENGINE INSTALLATION

The engine installation is the reverse of the removal procedure. However, pay attention to the following.

1. Prior to install engine, inspect condition of engine mountings. If necessary, replace the engine mountings, you can insert a punch in hole of engine mounting bushing and push the other bushing out of the housing.
2. Make sure coolant and oil drain plugs are reinstalled and tight.
3. Refill engine oil and check the oil level with the dipstick.
4. Install new gaskets on the exhaust pipes. Secure the exhaust pipe on cylinder head with exhaust nuts.
5. Ensure tighten the bolts to the specified torque.

Installation location	Specifications (mm)	Torque N.m(kgf.m)
Mounting nut of engine	M10	70(7.1)
Nut of exhaust pipe	M8	30(3.1)
Bolt of front propeller shaft flange	M8	40(4.1)
Bolt of rear propeller shaft flange	M10	80(8.2)

6. Install the connectors rightly of ignition coil, fuel injector and oxygen sensor, the wire mark of front cylinder is red, the wire of rear cylinder is blue.

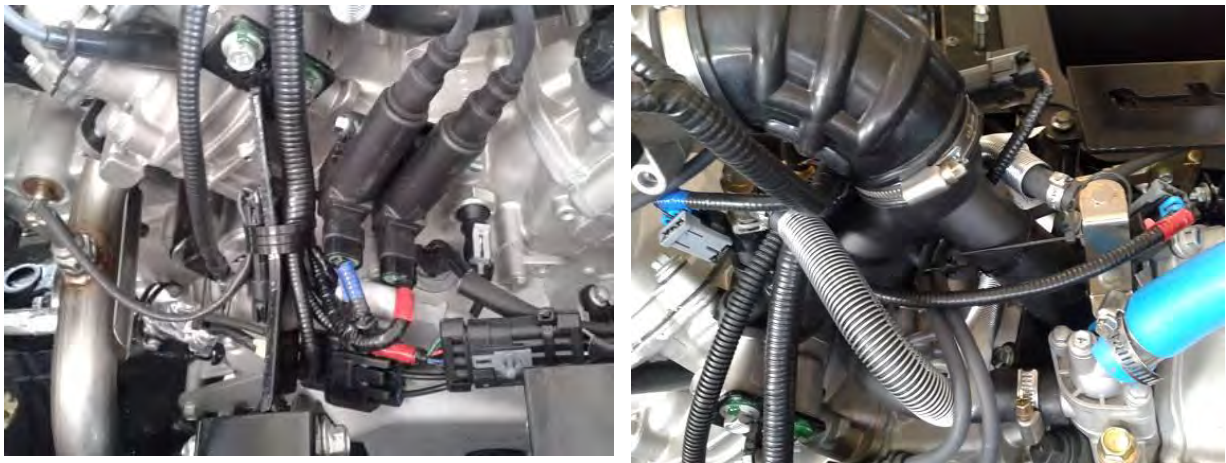

7. After installing the engine, route the wire harness and hoses properly.
8. Adjustment the parking brake, refer to PERIODIC MAINTENANCE.
9. Replacement the coolant, refer to PERIODIC MAINTENANCE
10. Start vehicle, let engine reaches the operating temperature, test drive vehicle to confirm proper operation, then stop engine and check if coolant and oil levels are correct, refill as necessary.

4. COOLING SYSTEM

FAULT OVERHAULING	4-1	COOLING SYSTEM TEST	4-2
THERMOSTAT	4-3	RADIATOR AND CAP	4-3
COOLANT TANK	4-5	RADIATOR FAN	4-6
WATER PUMP HOUSING	4-6	WATER PUMP IMPELLER	4-7
WATER PUMP SHAFT AND SEALS	4-7	WATER TEMPERATURE SENSOR	4-11

Fault overhauling

1. If cover of radiator is open and temperature of cooling liquid is over 100°C, pressure of cooling liquid will be reduced rapidly and boiled. Vapor injection may cause danger and injuries. After drop of temperature of cooling liquid, use one cloth to cover the cover of radiator and then slowly open the cover. Cooling liquid can only be tested after complete cooling.
2. Cooling liquid is toxic. Do not drink it or splash it to skin, eyes or clothes. In case of splashing cooling liquid to your eyes, use clean water to wash your eyes completely and see the doctor. In case of splashing cooling liquid to your clothes, use soapy water to wash it rapidly. In case of drinking cooling liquid, vomit will be caused immediately. Please see the internist physician immediately. Store cooling liquid well and keep it out of reach of children.
2. Check whether soil of fins is blocked or damaged. Correct curved fins. Use water and compressed air to clean soil. If damaged area reaches 20%, please replace radiator.
3. Pump overhauling can be carried out before dismantling engine.
4. Only add cooling liquid to water tank in normal times. In addition to adding or exhausting cooling liquid, please do not open cover of radiator.
5. Do not splash cooling liquid to plastic parts. Once splashed, please use clean water for washing.
6. After dismantling cooling system, check leakage situation of joint.

Sharp rise of water temperature

- z Faults of radiator cover
- z There is air in cooling system
- z Faults of water pump
- z Faults of thermostat (thermostat is not open)
- z Blockage of radiator tube or cooling tube
- z Damage or blockage to radiator
- z Incomplete cooling liquid
- z Failure or faults of fan motor

No rise or slow rise of water temperature.

- Z Faults of thermostat (thermostat is not closed)
- Z Faults of line of water temperature display

Leakage of cooling liquid

- z Faults of water seal
- z Aging, damage or improper sealing to O-shaped ring
- z Aging, damage or improper sealing to gasket
- z Improper installation of pipe or hose
- z Aging, damage or improper sealing to pipe and/or hose

WARNING!

Never start engine without coolant. Some engine parts such as the rotary seal on water pump shaft can be damaged.

COOLING SYSTEM TEST**WARNING**

To avoid potential burns, do not remove the radiator cap or loosen the cooling drain plug if the engine is hot.

Open the upper cover of engine hood and remove the radiator cap.

Install the test cap and a small hose pincher on overflow hose.

Using pressure pump, pressurize system to 100 kPa.



Check all hoses, radiator and cylinder(s)/base for coolant leaks or air bubbles.

Inspection

Check general condition of hoses and clamps tightness.

Check the leak indicator hole if there is oil or coolant.

NOTE: Flowing coolant indicates a defective rotary seal. Oil indicates a defective inner oil seal. If either seal is leaking, both seals must be replaced at same time. Refer to *WATERPUMP SHAFT AND SEAL* in this section.

1. leak indicator hole

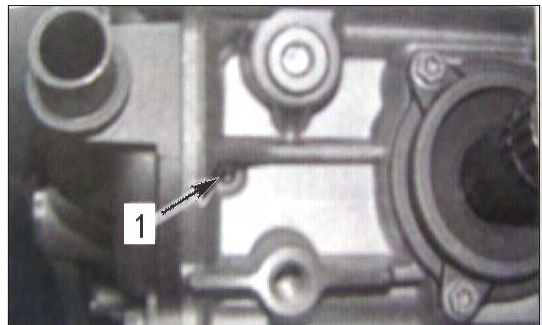

Another leak indicator hole is visible on the PTO side. It indicate if the PTO gasket is in good condition. If a liquid leaks by this hole, the PTO gasket replacement is necessary.

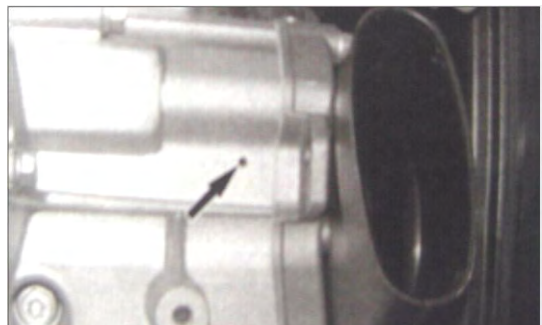

THERMOSTAT

The thermostat is a single action type. The thermostat is located on the top of cylinder head, on intake side.

Remove:

- thermostat housing screws and pull thermostat cover

1. Thermostat cover
2. Screws

- thermostat with gasket out of the hole.

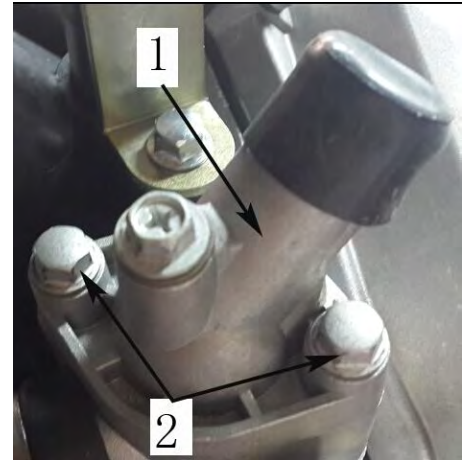

Thermostat test

To check thermostat, put in water and heat water.

Thermostat should open when water temperature reaches 65°C(149°F).

Check if the gasket is brittle, hard or damaged. If so replace gasket.

Thermostat installation

For installation, reverse the removal procedure, pay attention to the following details.

Install the thermostat cover then torque screws to 10N.m.

Check coolant level in radiator and coolant tank and top up if necessary.

Do not forget to bleed the cooling system. Refer to COOLANT REPLACEMENT.

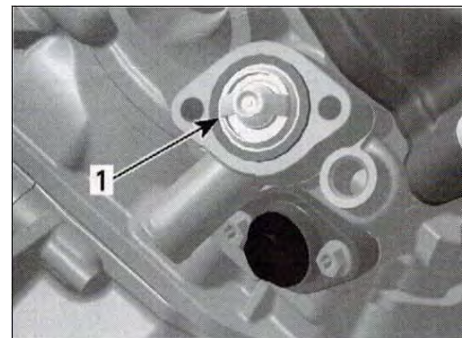

RADIATOR AND CAP

Using a pressure cap tester, check the efficiency of radiator cap. If the efficiency is feeble, install a new 100 kPa cap (do not exceed this pressure).

Radiator removal

Drain cooling system.

Remove the upper cover of engine hood and the cover of battery box



Disconnect connectors of the relay and battery. Remove the battery.

Remove the fuse box and battery box.

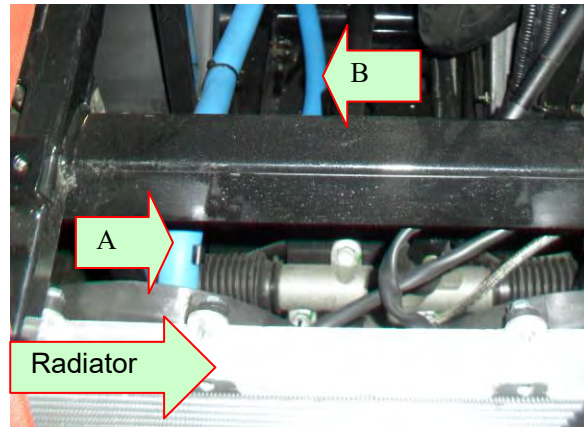

Remove the radiator water inlet hose A and top mounting bolt on the right side.



Remove the connector of temperature controller on the radiator and the radiator water outlet hose B.

Remove the fill hose C and the top mounting bolt D on the left side.

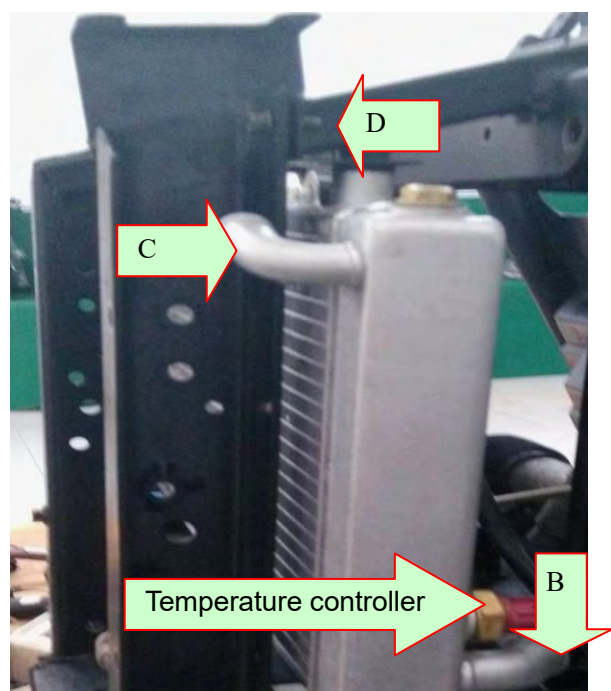

Unplug the connectors of cooling fan.

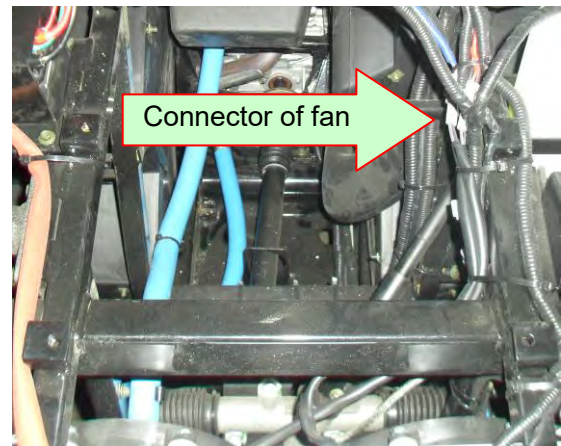

Pull out upward the radiator from the lower mounting holes on the frame, remove the radiator from the left side of the vehicle.

Radiator inspection

Check radiating fins for clogging or damage. Remove insects, mud or other obstructions with compressed air or low pressure water.

Radiator installation

For installation, reverse the removal procedure. Pay attention to the following detail. Fill up the radiator. Check for any coolant leakage from radiator and hoses.

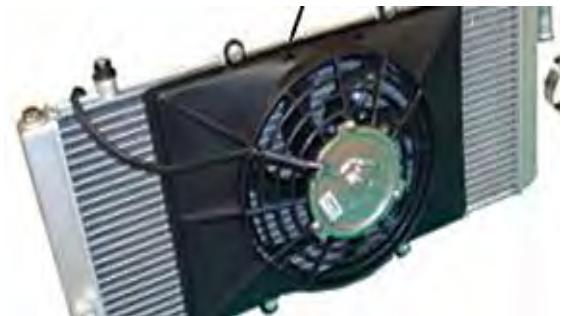

COOLANT TANK

The coolant expands as the temperature (up to 100-110°C) and pressure rise in the system. If the limiting system working pressure cap is reached 110kPa, the pressure relief valve in the pressure cap is lifted from its seat and allows coolant to flow through the overflow hose into the overflow coolant tank.

Tank removal

Remove:

- The upper cover of engine hood.
- Coolant tank support bolt.
- Overflow hose and clamp.

Tank installation

The installation is the reverse of the removal procedure.

Refill coolant to upper level mark, it is about 650ml.



RADIATOR FAN

Radiator fan removal

Remove the mounting bolts.

Remove the radiator fan.

Radiator fan test

The radiator fan should turn on when coolant temperature reaches 82°C and should turn off when the coolant cools down at 80°C. It should turn on when connecting to battery directly by cables.

Radiator fan installation

For the installation, reverse the removal procedure.



WATER PUMP HOUSING

It is located on the engine MAG side.

Water pump housing removal

Drain cooling system.

Remove radiator outlet hose from water pump housing.

Remove screws retaining water pump housing.

1. Screws
2. Water pump housing
3. Sealing ring

Pull water pump housing to remove it.

Water pump housing inspection

Check if gasket is brittle, hard or damage and replace as necessary.

1. Gasket

Water pump housing installation

The installation is the opposite of the removal procedure.

CAUTION: To prevent leaking, take care that the gasket is exactly in groove when you reinstall the water pump housing.

Tighten screws of water pump housing in a crisscross sequence.

WARNING

To avoid potential burns, do not remove the radiator cap or loosen the cooling drain plug if the engine is hot.

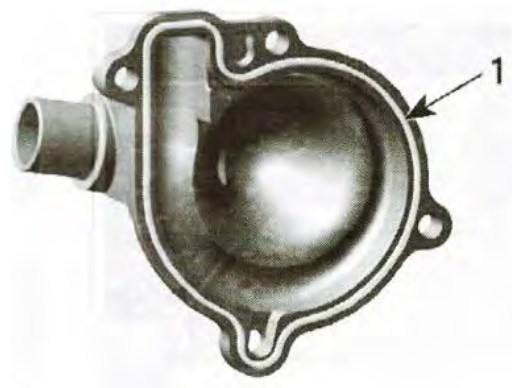
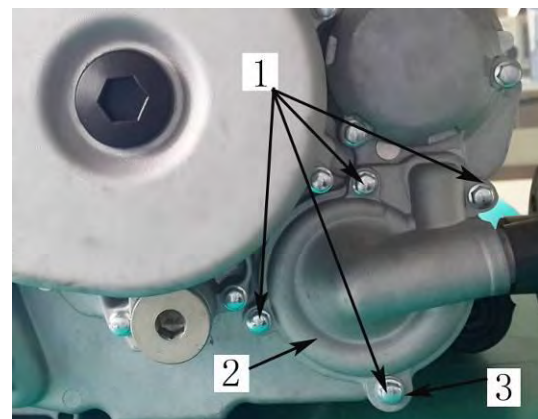

WATER PUMP IMPELLER

Impeller removal

Remove water pump housing.

Unscrew impeller.

1. Impeller

CAUTION:

Water pump shaft and impeller have right-hand threads. Remove by turning counterclockwise and install by turning clockwise.

Check impeller for cracks or other damage.

Replace impeller if damaged.



Impeller installation

The installation is the opposite of the removal procedure. Be careful not to damage impeller wings during installation.

WATER PUMP SHAFT AND SEALS

Shaft/Seal removal

NOTE: It is not required to split crankcase to replace the water pump shaft and seals, but engine removal is necessary.

Drain engine oil.

Remove engine from vehicle. Refer to ENGINE REMOVAL section.

Detach gearbox from engine.

Remove engine drive shaft and engine PTO cover.

Remove water pump housing and impeller. See procedures in this section.

Pull out water pump gear to disengage the inner drive gear.

1. water pump gear

2. Inner drive gear

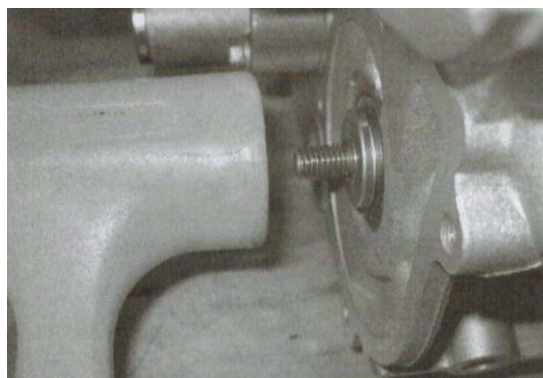
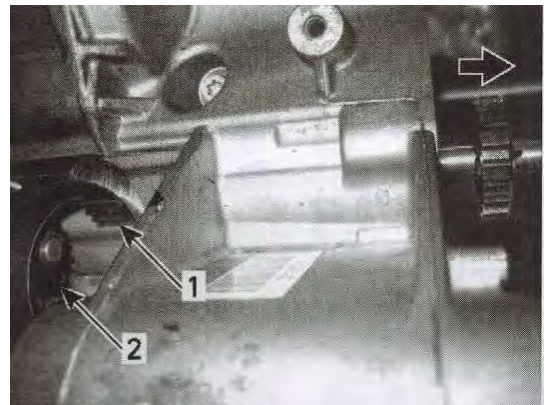

Sharply strike water pump shaft out with a plastic hammer.

Pull out water pump shaft through the engine drive shaft opening.

NOTE: Pay attention to hold thrust washer to prevent it from falling in crankcase.

1. Thrust washer here

CAUTION: If thrust washer is not on water pump shaft, use a magnet to retrieve it inside crankcase.

Using appropriate pliers remove and discard the retaining ring securing water pump gear on water pump shaft.

To remove plastic gear from water pump shaft place gear between your fingers and briskly tap shaft end.

Using 2 screwdrivers, pry out inner part of the rotary seal.

To remove outer part of rotary seal, use an expander from puller kit.

Install expander snugly against outer part and pull rotary seal out.

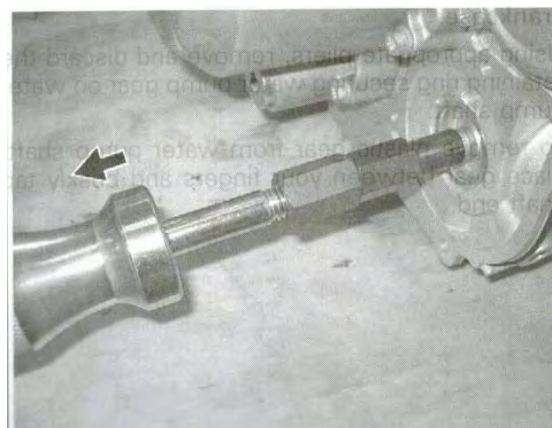
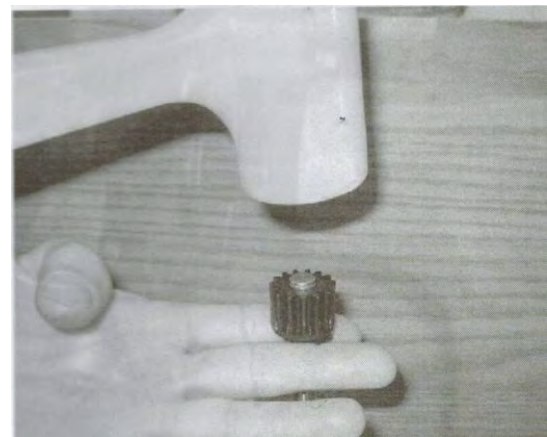
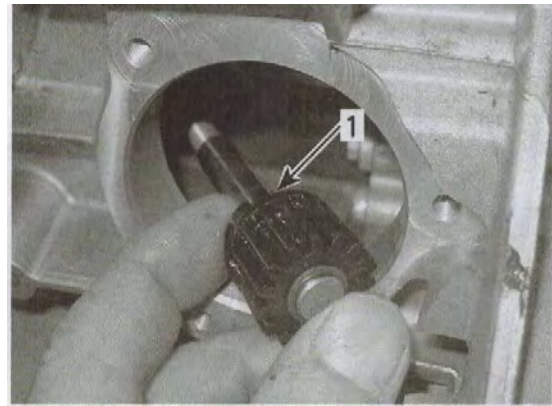

Remove inner oil seal.

1. Inner seal
2. Rotary seal surface

CAUTION: Be careful not to damage the rotary seal surface in crankcase.

Inspection

Inspect water pump gear for wear and damage on the snap mechanism to the needle pin. Replace if damaged.

Shaft/Seal installation

For installation, reverse the removal procedure. However, pay attention to the following.

NOTE: For installation use the torque values. Ensure to use multipurpose grease oil seal.

CAUTION: Always replace rotary seal and water pump shaft together. Also, install a new inner oil seal (behind rotary seal) at the same time.

Apply engine oil on the water pump shaft and intermediate shaft.

NOTE: Never use oil in the press fit area of the oil seal and rotary seal.

Use the oil seal pusher and the installer Handle to install inner oil seal.

1. Handle
2. Pusher

Apply MOLYKOTE inside lips oil seal when installing the oil seal on the pusher, make sure sealing lip points outside.

Push inner oil seal in place.

1. Inner oil seal
2. Installer handle with oil seal pusher

Slide water pump shaft with the new rotary seal into crankcase.

To properly install water pump shaft with rotary seal, use the rotary seal installer.

Use a plastic hammer and drive rotary seal into crankcase.

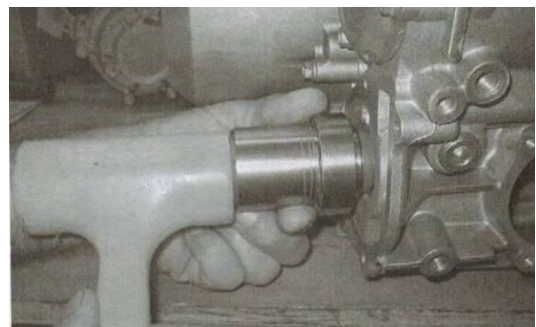
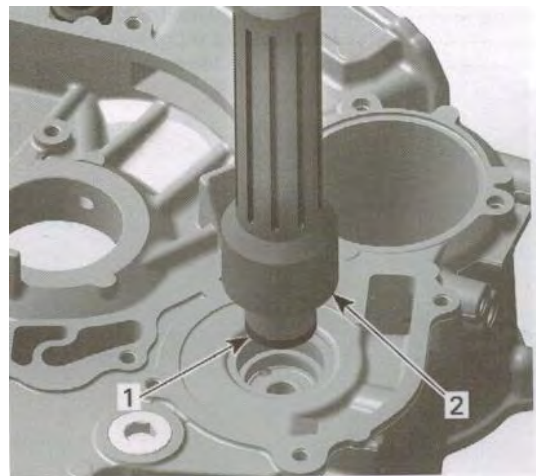
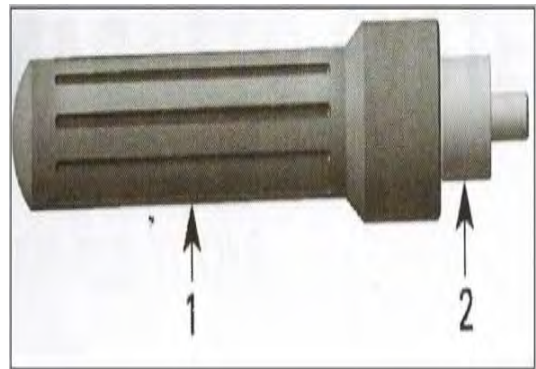
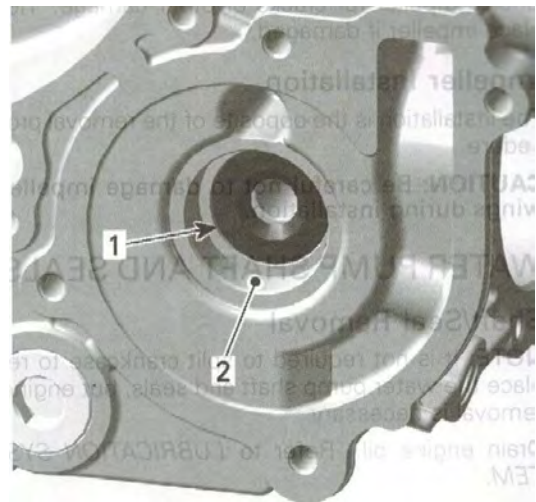

From engine drive shaft opening. Insert thrust washer pump shaft in crankcase.

Using a flashlight and a mirror, position the shaft hole so that pin can be installed.

Position pin between your fingers, push in water pump shaft to fully expose hole then install pin.

Position pin equal distance out of shaft hole so gear can be installed.

Install water pump shaft gear.

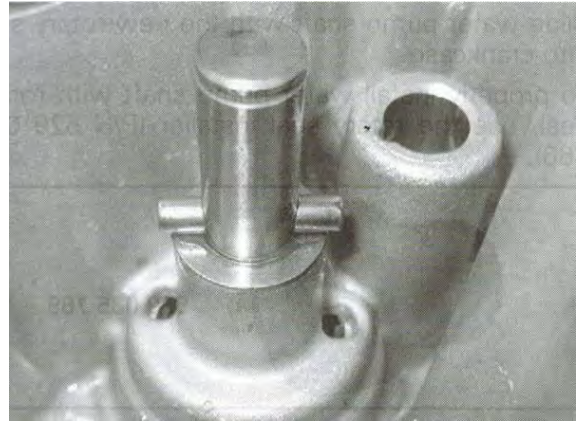

NOTE: Ensure gear properly snaps on pin.

A screwdriver may have to be used to push gear in place.

Use a snap ring pliers and install a new retaining ring on pump shaft end.

CAUTION: Never use the retaining ring a second time. Always install a new one.

After installation, water pump shaft with rotary seal must rotate freely.

Carefully push in water pump gear while turning to mesh with the inner drive gear.

1. Water pump gear
2. Inner drive gear

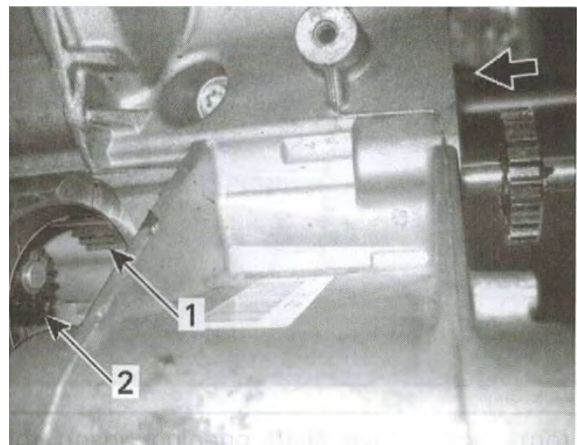

Tighten Screws of the water pump housing crosswise.

Refill all coolant.

Water temperature sensor Removal and Inspection

Disconnect and remove sensor from rear cylinder head.

Place sensor into container with cooling liquid and slowly heat it to measure its resistance. Temperature meter cannot get in contact with container bottom.

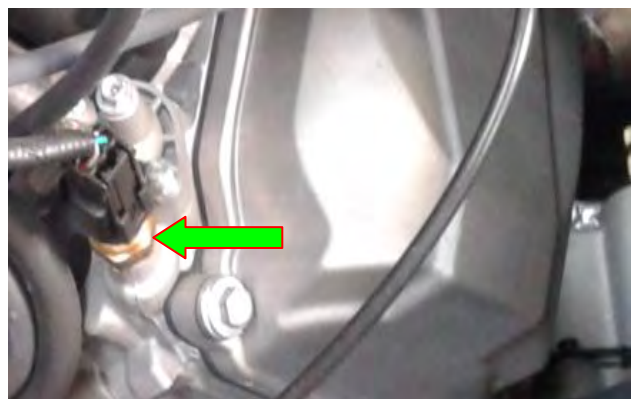

Temperature	Resistance
50°C	216-264 Ω
60°C	148-180 Ω
80°C	74.6-90.6 Ω
90°C	53.5-66.5 Ω
100°C	40.6-48.6 Ω

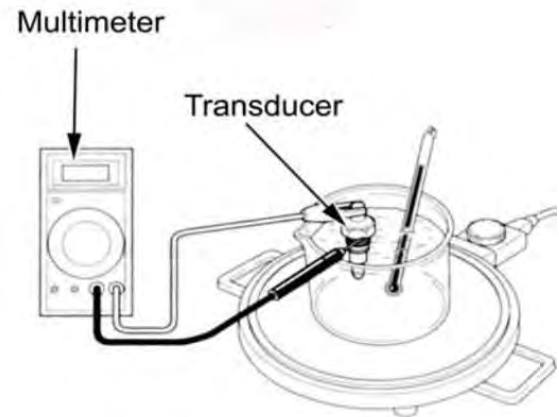

In case of exceeding effective range of sensor: → please replace it

Sensor installation

Screw sensor with 16N.m.

Fill in cooling liquid fully and bleed air.

5. FUEL SYSTEM

FUEL PRESSURE TEST-	5-2	FUEL FILTER-	- 5-2
FUEL PUMP-	- 5-2	FUEL TANK-	- 5-4



The fuel system of a fuel injection system holds much more a pressure than on carbureted vehicle. Prior to disconnecting a hose or to removing a component from the fuel system, follow the recommendation described here.

Fuel lines remain under pressure at all times. Always proceed with care and use appropriate safety equipment when working on pressurized fuel system. Wear safety glasses. Proceed with care when removing/installing pressure test equipment or disconnecting fuel line connections. Cover the fuel line connection with an absorbent shop rag. Slowly disconnect the fuel hose to minimize spilling. Wipe off any fuel spillage in the engine compartment. Do not allow fuel to spill on hot engine parts and/or electrical connectors. Never use a hose pincher on injection system high pressure hoses. Replace any damage or deteriorated fuel lines.

When the repair is completed, ensure that all hoses are connected and secured.

Always perform the fuel pressure test if any component has been removed. A pressure test must be done before turning the ignition key to ON and setting the engine stop switch to RUN. The fuel pump is activated each time in these conditions.

To locate a leak, pressurize the system. Check for leaking fuel or fuel odor. Spray soapy water on all hose connections and injectors. Air bubbles will show the leaking area.

Inspect the fuel lines, fuel tank, fuel tank cap for damage, clogging and leakage of fuel. If any damages are found, replace the defective parts with the new ones.

FUEL PRESSURE TEST

The pressure test will show the available pressure at the fuel pump outlet. It validates the pressure regulator, the fuel pump and leaks in the system.

Before proceeding to the pressure test ensure the battery is fully charged. Battery voltage must be over 12 volts.

Ensure there is enough gas in fuel tank.

Remove left seat.

Disconnect outlet hose.

Install fuel pressure gauge and T-fitting between disconnected hoses.

Turn ignition key ON and set engine stop switch to RUN and observe fuel pressure. Turn ignition key off then back on. Repeat the test.

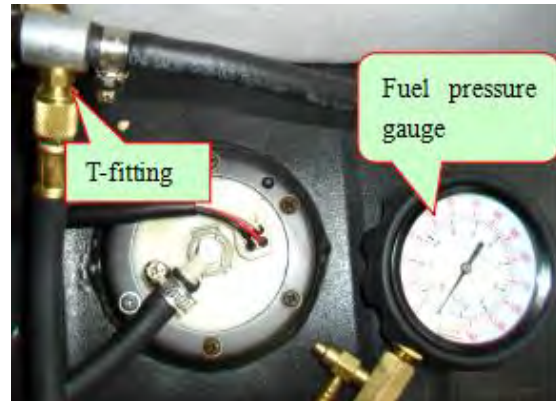

Standard fuel pressure: 350kpa.

A rapid pressure drop indicates leakage is from the fuel rail, If there is not leaking then replace fuel pump.

A slow pressure drop indicates leakage either from the fuel injector or from the fuel pressure regulator. Check fuel injector and the fuel pressure regulator for leaks. If it is not leaking then replace fuel pump module.

If no leakage, start engine and observe fuel pressure. The fuel pressure should be the same as above.

If pressure is within limits, fuel pump and the fuel pressure regulator are working adequately.

Remove pressure gauge from inlet hose. Reconnect inlet hose.

FUEL FILTER

Replace fuel filter as per maintenance schedule.

Filter Removal

Remove clamps and pull hoses off. Detach filter from body.

Filter inspection

If fuel filter is suspected to be clogged, it may be checked as follows:

Using low compressed air, check if fuel filter is clogged. Air should flow easily through filter. In doubt, install a new filter.

Filter installation

Use arrow on filter to position it according to fuel flow.

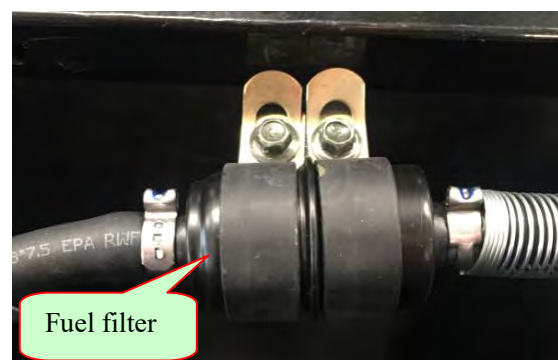

FUEL PUMP

Fuel pump electrical test.

When turning ignition key ON, the fuel pump should run for 5 seconds to build up the fuel pressure in the system.

If the pump does not work, disconnect the connector from the fuel pump.

Install a temporary connector to the fuel pump connector. Apply 12V to this test harness.

CAUTION

Running the fuel pump a few minutes with reverse polarity can damage the pump.

If pump does not run, replace a new pump.

Other wise, check fuse and if good, probe terminals of fuel pump connector on vehicle harness or its connector, Repair or replace appropriate part.

Fuel pump removal

Remove fuel pump outlet hose and harness.

Remove fuel pump retaining screws.

Gently push pump up.

CAUTION

While pulling out the fuel pump, pay attention to fuel sensor float arm. Float arm can get stuck and bend which can reduce the fuel sensor capabilities.

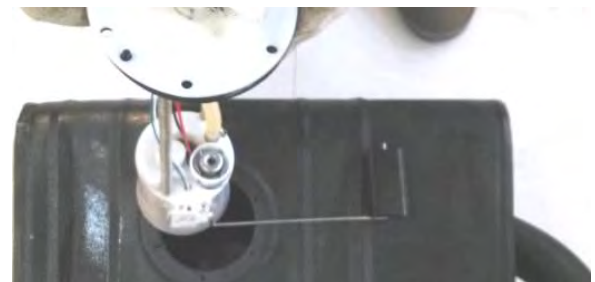
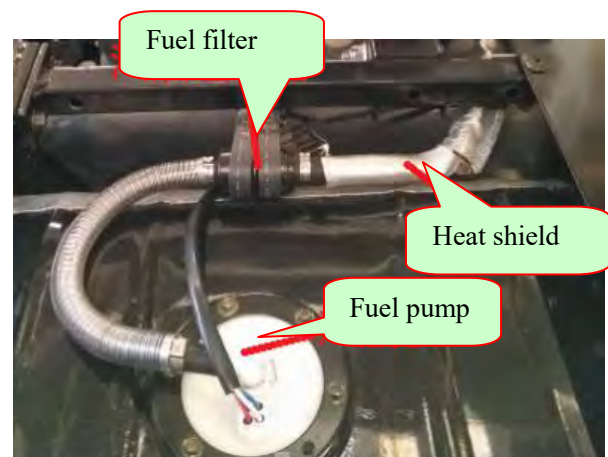

Fuel pump installation

For installation, reverse the removal process but pay attention to the following.

Install a new gasket.

Pay attention to pump orientation.

Tighten retaining screws as per illustrated sequence.

Install hose properly on OUT nipples and harness.

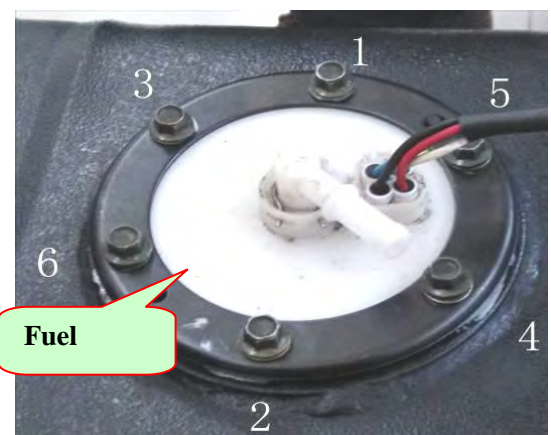

FUEL SENSOR

The level sensor is part of the fuel pump module mounted inside the fuel tank.

Inspection

Dismantle the fuel pump module mounted inside the fuel tank (refer to above steps)

Turn on ignition switch

Use hands to shake fuel sensor's floating device, locating floating device to see whether it is fit with indication of fuel meter.

Turn off the ignition switch and disconnect connector, measure resistance:

Lower: BLUE/WHITE: 6-9Ω

Lift: BLUE/WHITE: 90-95Ω



If the resistance is not within empty and full values, replace fuel pump module. If the fuel level sensor is good, try a new multifunction gauge.

Installation

Install fuel sensor to fuel tank.

Connect connector and hose.

Turn on fuel supply switch, and check whether functions of fuel meter is normal or not.

Fuel leakage is not allowed.

FUEL TANK

Fuel tank draining

Never perform this operation when the engine and/or the exhaust system is/are hot.

Remove fuel tank cap and siphon gas in an approved fuel container.

Fuel tank removal

Remove the right guard.

Remove the mounting plate of seat.



Remove the rear body guard (right).

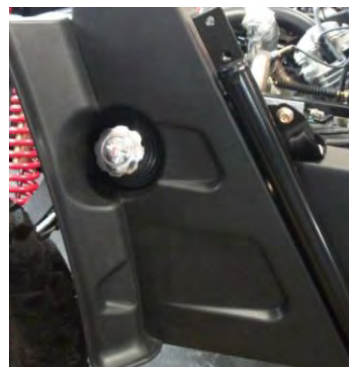

Disable fuel pump by removing the electrical connector from the fuel pump.

Remove fuel pump outlet hose.



Remove fuel pump retaining screws and hoops.



Remove the bolts of fuel tank retaining.

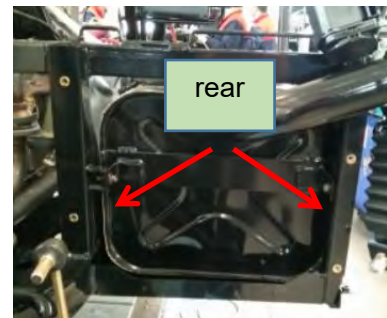
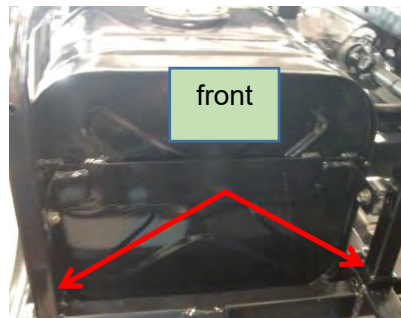

Pull front side of the fuel tank upward, continue lifting movement until you can remove the fuel tank completely.

Fuel tank inspection

Inspect fuel tank for any damage or cracks which may result in fuel leaks. If so replace tank with a new one. Inspect tank and protector attachment points for damage. Inspect protector for damage.

Fuel tank installation

For installation, reverse the removal process but pay attention to the following.
Reconnect fuel pump connector and fuel hose.

Tighten retaining screws.

Refuel tank and ensure there are no leaks.

Fuel pump installation

For installation, reverse the removal process but pay attention to the following.
Install a new gasket.

Pay attention to pump orientation.

Tighten retaining screws as per illustrated sequence.

Install hose properly on OUT nipples and harness.

FUEL TANK

Fuel tank draining

Never perform this operation when the engine and/or the exhaust system is/are hot.

Never use a hose pincher on injection system high pressure hoses.

Remove fuel tank cap and siphon gas in an approved fuel container.

Fuel tank removal

Remove

Disconnect vent line from body.

Fuel tank inspection

Inspect fuel tank for any damage or cracks which may result in fuel leaks. If so replace tank with a new one. Inspect tank and protector attachment points for damage. Inspect protector for damage.

Fuel tank installation

6. DRIVE TRAIN

FRONT DRIVE-	- 6-1	REAR DRIVE-	- 6-5
FRONT PROPELLER SHAFT-	6-1	REAR WHEEL HUB-	6-6
FRONT WHEEL HUB-	6-2	REAR DRIVE SHAFT-	6-7
FRONT DRIVE SHAFT-	6-3	REAR PROPELLER SHAFT-	6-7
FRONT DIFFERENTIAL-	6-4	REAR DIFFERENTIAL-	6-9
TIRES AND WHEELS.....	6-10		

FRONT DRIVE

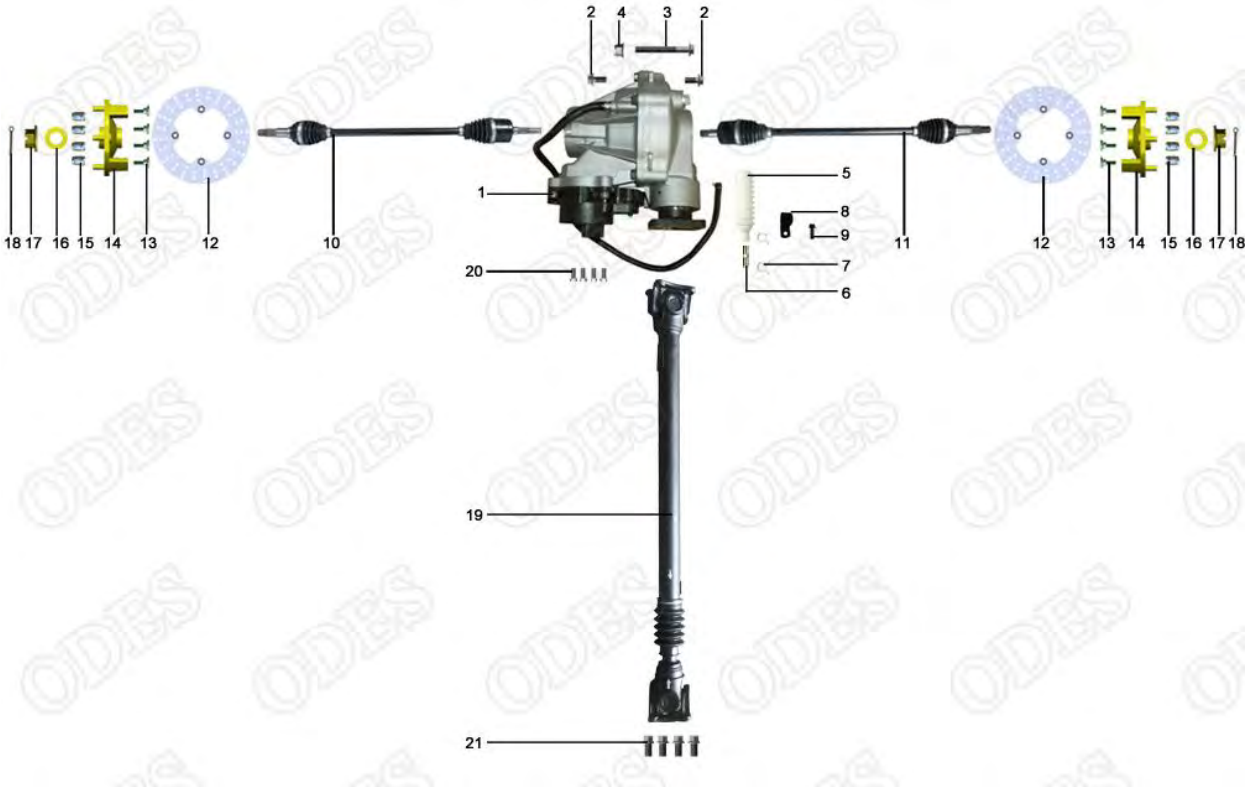

FRONT PROPELLER SHAFT

Removal

Place vehicle on PARK position and select 4WD.
 Remove left and right seats, gear shift handle and engine shield.
 Unscrew propeller shaft bolt on engine side.

Loosen the right front wheel nut.
 Raise the front of vehicle, support it securely on jack stands.

Remove the right front wheel and the ball joint of tie rod from the steering knuckle.



Remove propeller shaft bolts on front differential side.



Inspection

Inspect the propeller shaft for wear or damage. If any defects are found, replace the propeller shaft with new one.

Check if U-joint moves freely in all direction.

Check bellows for holes or brittleness.



Installation

Installation is the reverse of removal procedure. Ensure tighten the bolts to the specified torque.

Installation location	Specifications (mm)	Torque N.m(kgf.m)
Bolt of front propeller shaft flange	M8	40(4.1)
Bolt of front propeller shaft flange	M10	80(8.2)

FRONT WHEEL HUB

Removal

Raise the front of vehicle, support it securely on jack stands and remove front wheel.

Remove cotter pin, castellated nut and Belleville washer.

Remove the caliper from knuckle.

Pull the wheel hub to remove it.

Inspection

Check wheel hub for cracks or other damages.

Check inner splines and wheel rim bolts for wear or other damages.

If any damage is detected on wheel hub, replace it with a new one.

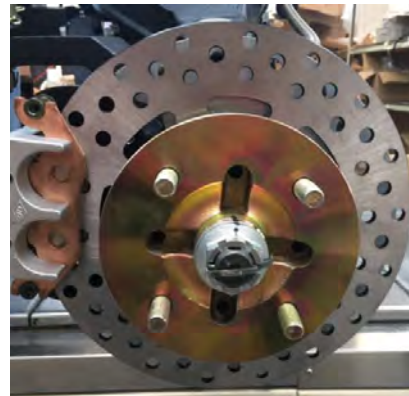

Installation

The installation is the reverse of removal procedure.

Install washer so that the inside diameter protrudes outward and contacts the nut.

Tighten the castellated nut on the drive shaft end to 300N.m and further tighten until one of its grooves is aligned with a cotter pin hole. Install a new cotter pin and the wheel cap. Fold one pin of cotter pin over drive shaft end.



FRONT DRIVE SHAFT

Removal

Remove the appropriate wheel hub.

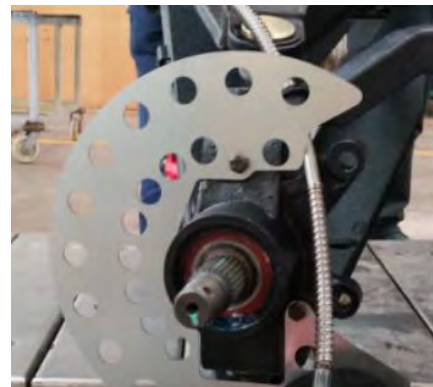

Remove the guard plate of brake caliper
Remove the fixing clip of brake hose on the knuckle.



Remove the shock absorber.
Remove the ball joint of tie rod from the steering knuckle.
Remove the nuts of knuckle upper and lower ball joint.
Remove the knuckle.



Pull drive shaft out of differential.



Inspection

Inspect the condition boots. If there is any damage or evidence of leaking lubricant, replace them.

Check splines for excessive wear. Replace if necessary. If the splines on plunging joint are worn, a check of differential inner splines should be done.

Check the ring at the end of drive shaft. If wear is apparent, replace the wear ring.

Check if the bearing in knuckle move freely and smoothly. If not, replace them.

**Installation**

Apply grease to the splines and insert the end of drive shaft in differential and pull joint a little to make sure that the stop ring is locked in differential side gear groove.

Insert the other end of drive shaft in the knuckle and install the knuckle to the lower suspension arm. Install and torque the ball joint retaining bolts to 45N.m

Install all other removed parts.

FRONT DIFFERENTIAL**Remove**

Clean the drain plug area. Place an oil pan under the front reducer case, and then drain oil completely by removing the drain plug.

Raise front of vehicle, support it securely on jack stands and remove front wheels.

On both sides, remove the drive shafts.

Remove upper differential bolts, differential support bolts and lower differential bolts

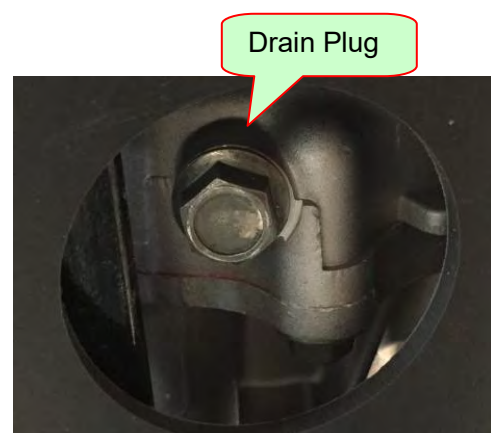

Remove the front differential.



Inspection

Inspect the gear case, case cover, bearing, oil seals and dust seal for wear or damage. If any damage or wear is found, replace the oil seal or dust seal with a new one.

Check back lash and drag torque.

Check the breather rubber case for wear or damage. Also, check that the joint of rubber case fits tightly.

Installation

The installation is the reverse of the removal procedure. Pay attention to refill the oil (GL-4-90). Ensure tighten the bolts to the specified torque.

Installation location	Specifications (mm)	Torque N.m(kgf.m)
Mounting nut of wheel rim	M10	60(6.1)
Nut of wheel hub	M22	300(30.6)
Fastening nut of front differential	M10	80(8.2)
Bolt of front propeller shaft flange	M8	40(4.1)
Bolt of front propeller shaft flange	M10	80(8.2)

REAR DRIVE

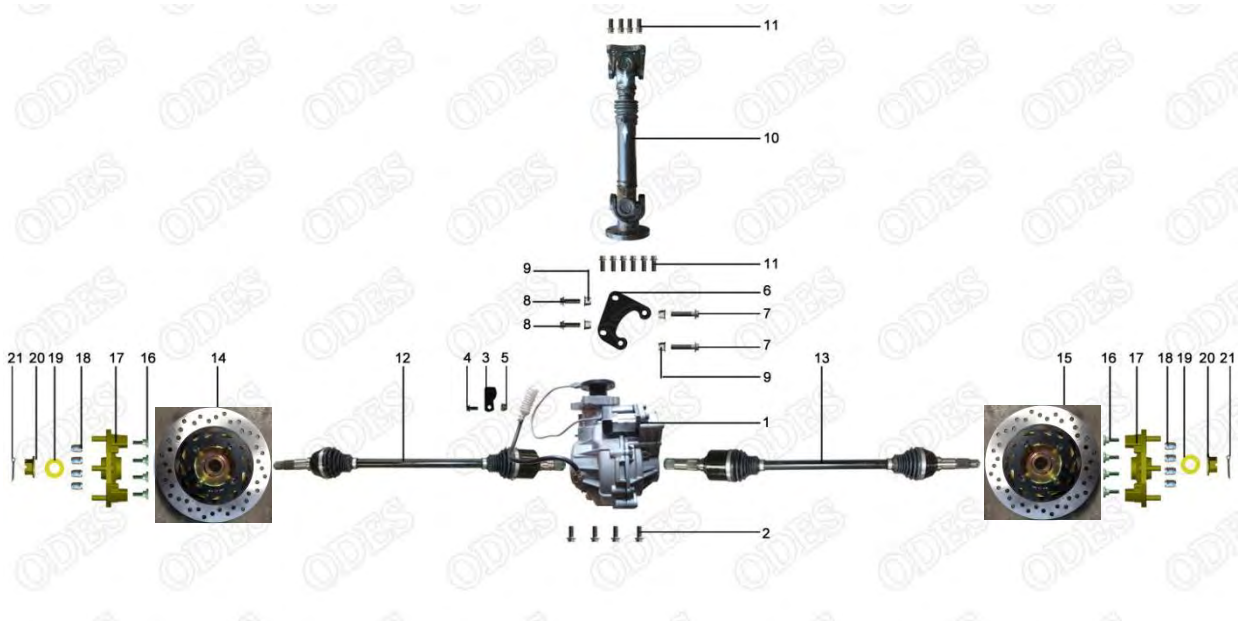

REAR WHEEL HUB

Removal

Loosen wheel nut of the appropriate.
 Install a jack stand under the frame to lift the rear of vehicle off the ground until the shock absorber is fully extended.
 Remove the rear wheel.
 Remove cotter pin, castellated nut and belleville washer.
 Remove the caliper from knuckle.
 Pull the wheel hub to remove it.

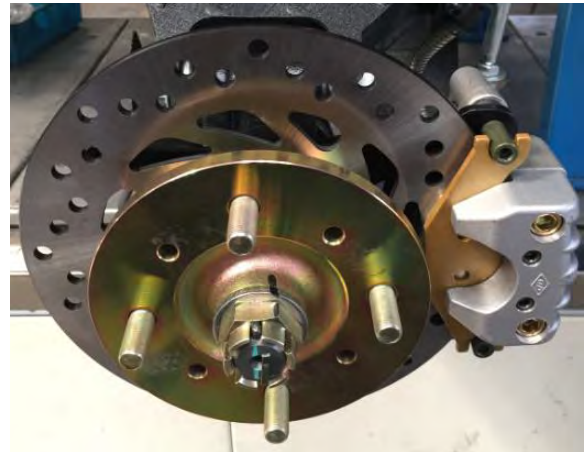

Inspection

Check wheel hub for cracks or other damages.
 Check inner splines and wheel rim bolts for wear or other damages.
 If any damage is detected on wheel hub, replace it with a new one.



Installation

The installation is the reverse of removal procedure.
 Install washer so that the inside diameter protrudes outward and contacts the nut.

Tighten the castellated nut on the drive shaft end to 300N.m and further tighten until one of its grooves is aligned with a cotter pin hole. Install a new cotter pin and the wheel cap. Fold one pin of cotter pin over drive shaft end.



REAR DRIVE SHAFT

Removal

Remove the appropriate wheel hub.
 Remove bolt that attach the shock absorber to the lower suspension arm.
 Detach lower suspension arm from knuckle.
 Separate knuckle from upper suspension arm.
 Remove the caliper.
 Pull drive shaft out of differential.

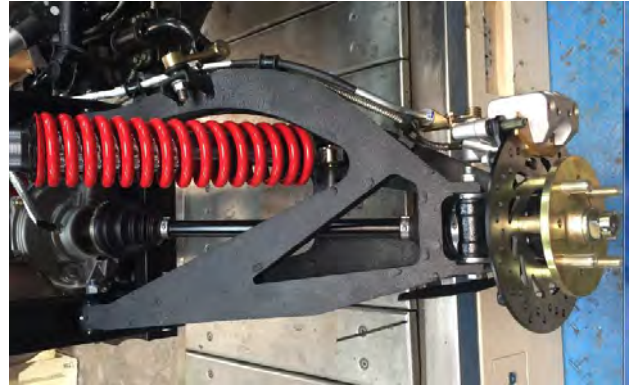

Inspection

Inspect the condition boots. If there is any damage or evidence of leaking lubricant, replace them.
 Check splines for excessive wear. Replace if necessary. If the splines on plunging joint are worn, a check of differential inner splines should be done.

Check the ring at the end of drive shaft.
 If wear is apparent, replace the wear ring.



Check if the bearing in knuckle move freely and smoothly. If not, replace them.



Installation

Apply grease to the splines and insert the end of drive shaft in differential and pull joint a little to make sure that the stop ring is locked in differential side gear groove.

Insert the other end of drive shaft in the knuckle and install the knuckle to the upper suspension arm.

Install all other removed parts.

REAR PROPELLER SHAFT

Removal

Place vehicle on PARK position and select 4WD.

Loosen the left rear wheel nut.

Install a jack stand under the frame to lift the rear of vehicle off the ground until the shock absorber is fully extended.

Remove the left rear wheel.

Remove the propeller shaft bolts on engine side.

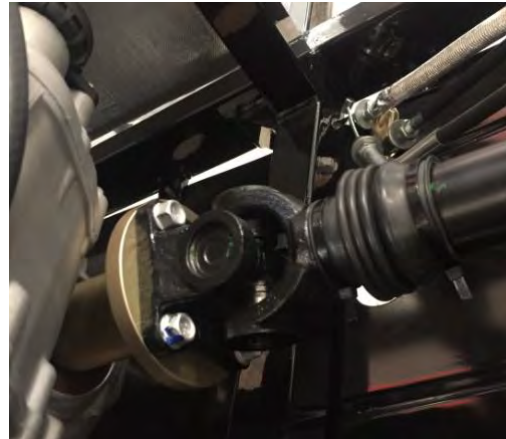
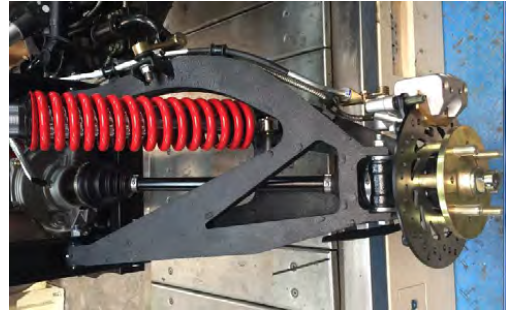

Remove propeller shaft bolts on rear differential side.



Remove the rear propeller shaft



Inspection

Inspect the propeller shaft for wear or damage. If any defects are found, replace the propeller shaft with new one.

Check if U-joint moves freely in all direction.

Check bellows for holes or brittleness.

Installation

Installation is the reverse of removal procedure. Ensure tighten the bolts to the specified torque.

Installation location	Specifications (mm)	Torque N.m(kgf.m)
Bolt of rear propeller shaft flange	M10	80(8.2)

REAR DIFFERENTIAL

Remove

Clean the drain plug area. Place an oil pan under the front reducer case, and then drain oil completely by removing the drain plug.

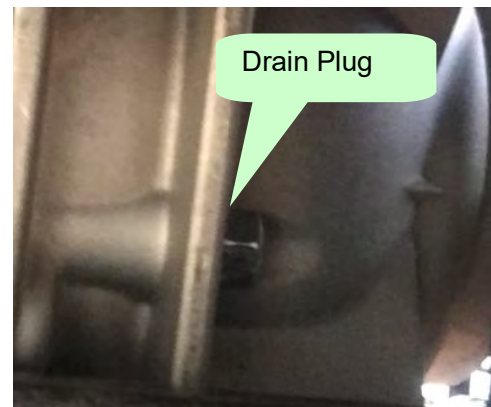

Raise rear of vehicle, support it securely on jack stands and remove rear wheels. On both sides, remove the drive shafts.

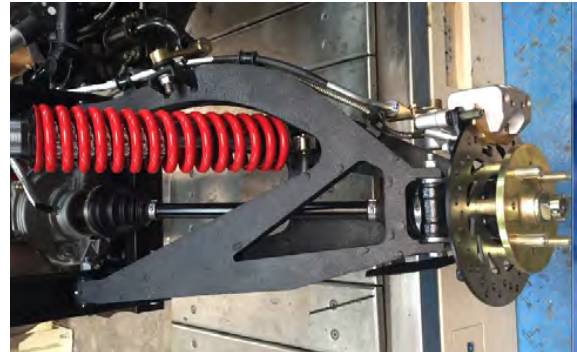

Remove propeller shaft bolts on rear differential side.



Remove upper differential bolts, differential support bolts and lower differential bolts

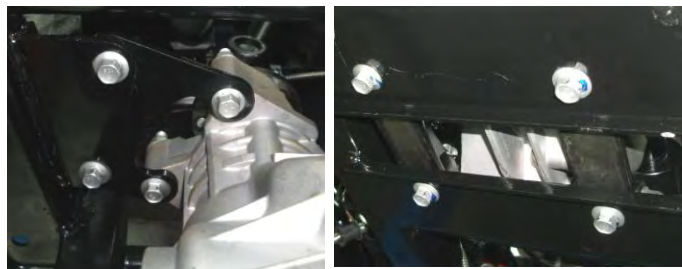

Remove the rear differential.



Inspection

Inspect the gear case, case cover, bearing, oil seals and dust seal for wear or damage. If any damage or wear is found, replace the oil seal or dust seal with a new one.

Check back lash and drag torque.

Check the breather rubber case for wear or damage. Also, check that the joint of rubber case fits tightly.

Installation

The installation is the reverse of the removal procedure.

Pay attention to refill the oil(GL-4-90).

Ensure tighten the bolts to the specified torque.

Installation location	Specifications (mm)	Torque N.m(kgf.m)
Mounting nut of wheel rim	M10	60(6.1)
Nut of wheel hub	M22	300(30.6)
Fastening nut of rear differential	M10	80(8.2)
Bolt of PARK brake caliper	M10	80(8.2)
Bolt of front propeller shaft flange	M10	80(8.2)

TIRES AND WHEELS

When the tires are replaced, never install a bias tire with a radial tire. such a combination could create handling and/or stability problems.

Dot mix tires of different size and/or design on the same axle.

Front and rear tire pairs must be the identical model and manufacturer.

For unidirectional tread pattern, ensure that the tires are installed in the correct direction of rotation.

The radial tires must be installed as a complete set.

In dismantling tires, use special crowbar and rim protection device.

Tire replacement

Use jack to support vehicle and ensure its no dropping.

Remove the wheels.

After removing the air valve cap, release the tire pressure by depressing the valve.

Dismount the bead from the rim completely.

Separate the tire from the rim by using a set of tire levers and rim protectors.

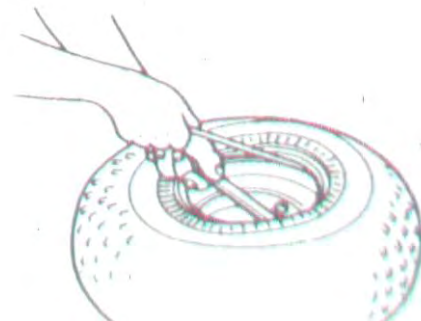
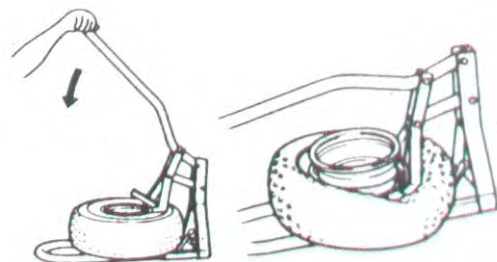
**CAUTION**

When using the tire lever, do not scratch or hit the sealing portion of the wheel or it may cause air leakage.

Apply tire lubricant to the new tire bead and the flange of the rim. But never apply grease, oil or gasoline to the tire bead because they will deteriorate the tire.

CAUTION

The standard tire fitted on this vehicle is AT29×8–15 for the front and AT29×10–15 for the rear.

The use of tires other than the standard may cause instability. It is highly recommended to use the specified tire.

Inspect the sealing portion of the rim for contamination and distortion before installing the tire on the rim.

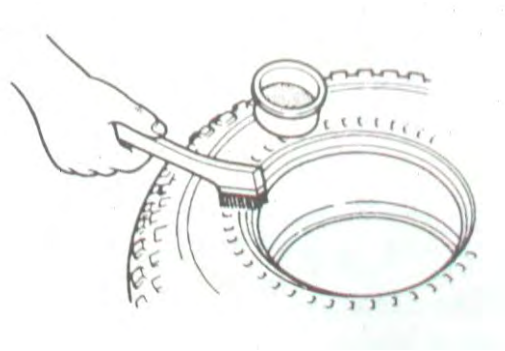

Mount the new tire on the rim.

CAUTION

When installing each tire, make sure the arrow on the tire points in the direction of rotation. Also make sure the outer side of the wheel rim is facing outward.



Inflate the tire to seat the tire bead.

Check the rim line cast on the tire side walls. It must be equidistant from the wheel rim all the way around. If the distance between the rim line and the wheel rim varies this indicates that the bead is not properly seated. If this is so, deflate the tire completely, and unseat the tire bead on both sides. Then coat the bead with clean water and re-seat the tire.

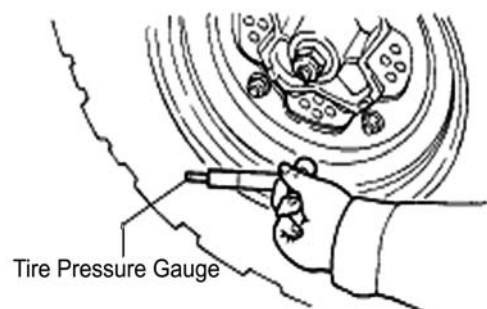

Adjust the tire pressure to specification.

7. STEERING SYSTEM

STEERING WHEEL.....7-1	STEERING ROD.....7-2
STEERING GEARBOX.....7-3	STEERING ALIGNMENT.....7-4

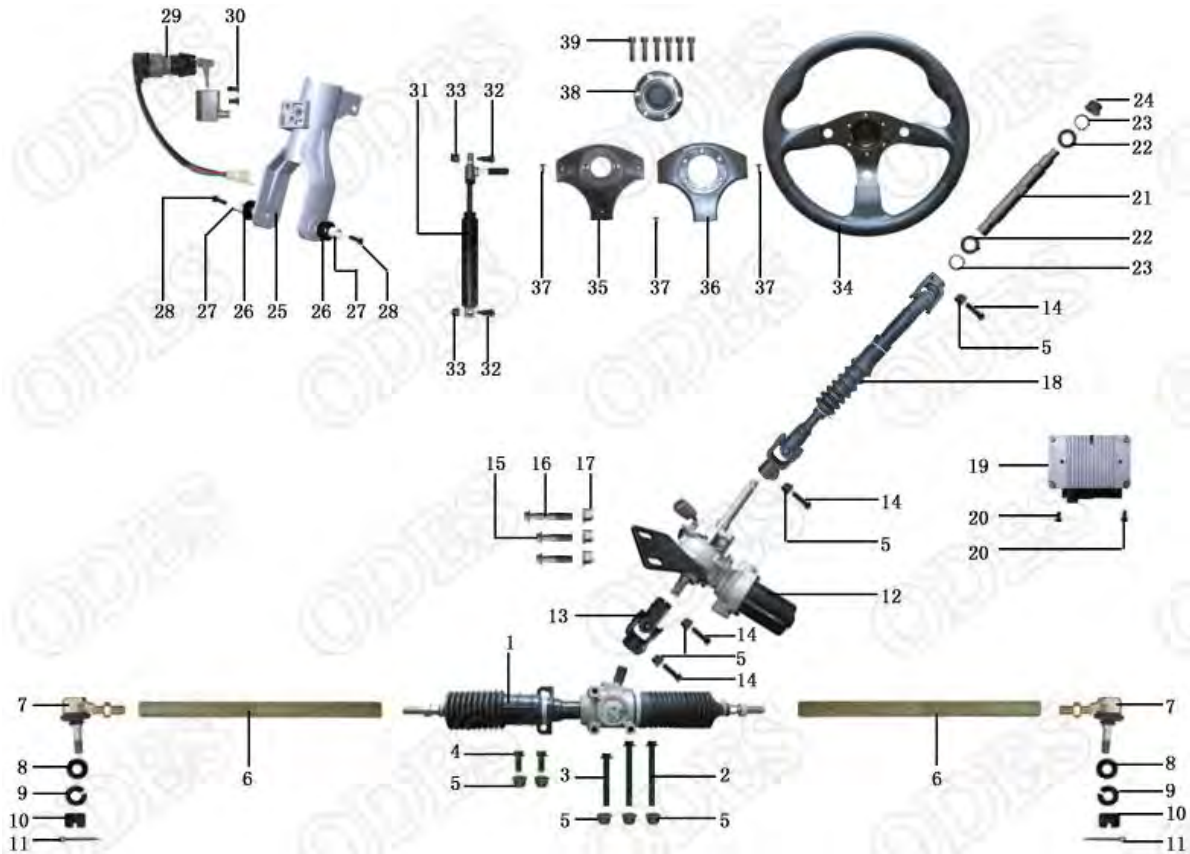

STEERING WHEEL

Inspect the steering wheel for distortion or damage. If any damage is found, replace the steering wheel with a new one

Removal

Remove the small cover of steering wheel.



Remove the mounting nut of steering wheel.

Remove the steering wheel.



Installation

The installation of steering wheel is the reverse of the removal procedure. Pay attention to torque the mounting nut of steering wheel to 120 N.m.

STEERING ROD

Inspect the steering rod for smooth movement. If there are any abnormalities, replace the steering rod with a new one.

Removal

Remove the steering wheel

Remove the mounting bolt A of the air spring.

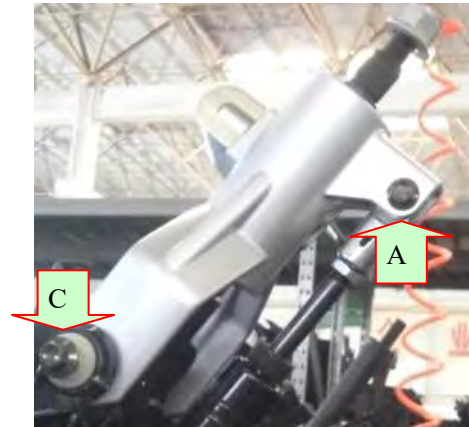

Unscrew the fixing bolt B on the connecting shaft of steering wheel.

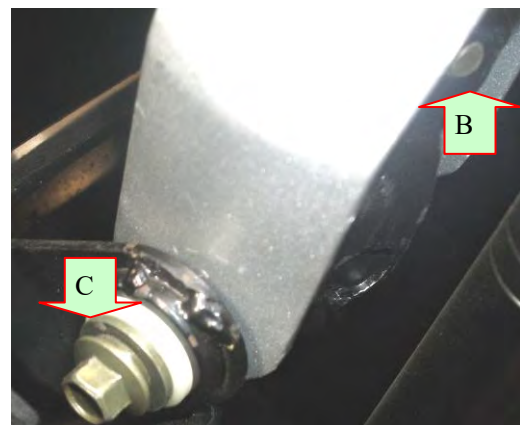

Remove the mounting bolts of the steering rod.

Remove the steering rod.



Installation

For the installation, reverse the removal procedure.

STEERING GEARBOX

Inspect the steering gearbox for smooth movement. If there are any abnormalities, replace the steering gearbox with a new one.

Removal

Remove the steering wheel and rod.
Remove the upper cover of engine hood and the cover of battery box

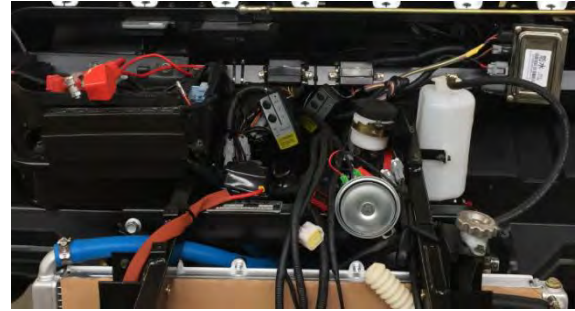

Disconnect connectors of the relay and battery.

Remove the battery.

Remove the fuse box and battery box.

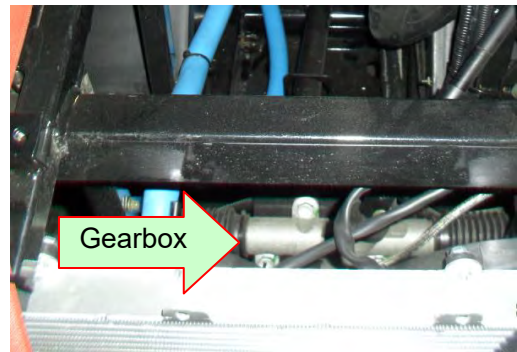

Unscrew the bolt A, remove the steering linkage.

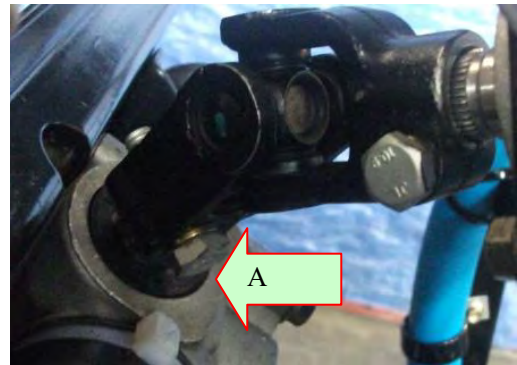

Remove the A B C mounting bolts.

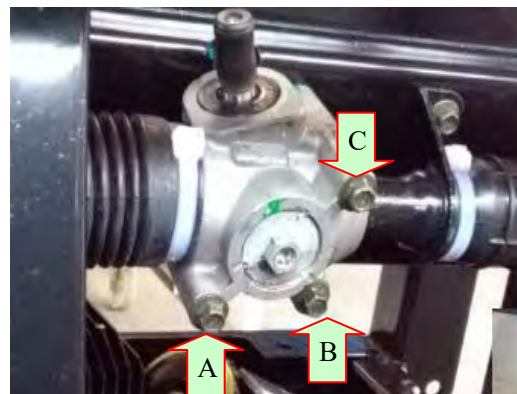

Remove the tie rod ball joints from the steering knuckle.

Remove the steering gear box.

**Installation**

For the installation, reverse the removal procedure. Ensure tighten the bolts to the specified torque.

STEERING ALIGNMENT

Park vehicle on flat ground, make sure the tire pressure for right and left tires is same and set to the proper specification, set the front wheels in the straight position, then place a load of 75kg on the seat.

Measure the distance A and B of the front wheels and calculate the difference.

Toe-in.: $B - A = 5\text{mm}$

A: front of front wheel

B: rear of front wheel

Out of range of toe-in: → Adjust nut of tie rod

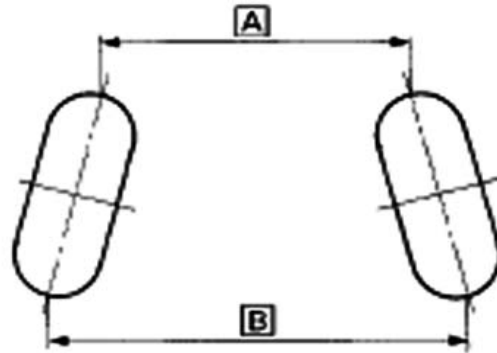
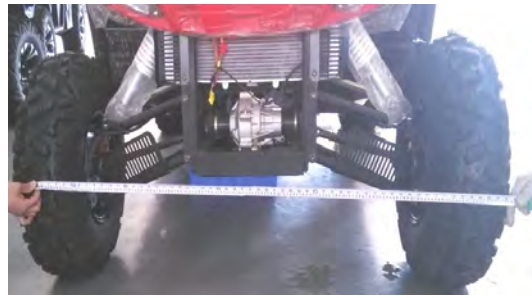

CAUTION

After adjusting toe-in, first rotate steering wheel from center position to the left and right completely, to ensure that is the same corner, then slowly run vehicle to see whether its direction can be controlled.

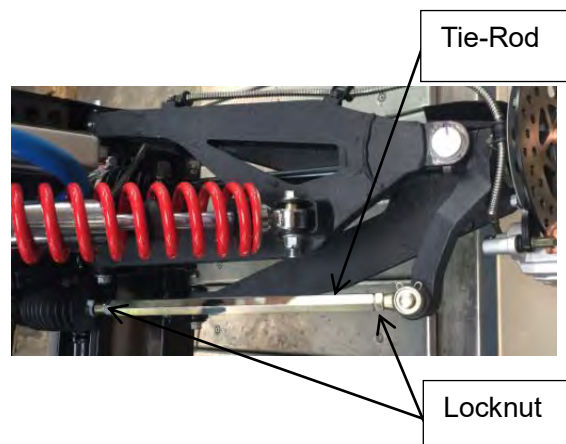

8. SUSPENSION SYSTEM

FRONT SUSPENSION-	8-1	REAR SUSPENSION-	8-4
REMOVAL AND DISASSEMBLY-	8-1	REMOVAL AND DISASSEMBLY-	8-4
INSPECTION-	- 8-2	INSPECTION-	- 8-4
REASSEMBLY-	- 8-3	REASSEMBLY-	- 8-5

FRONT SUSPENSION

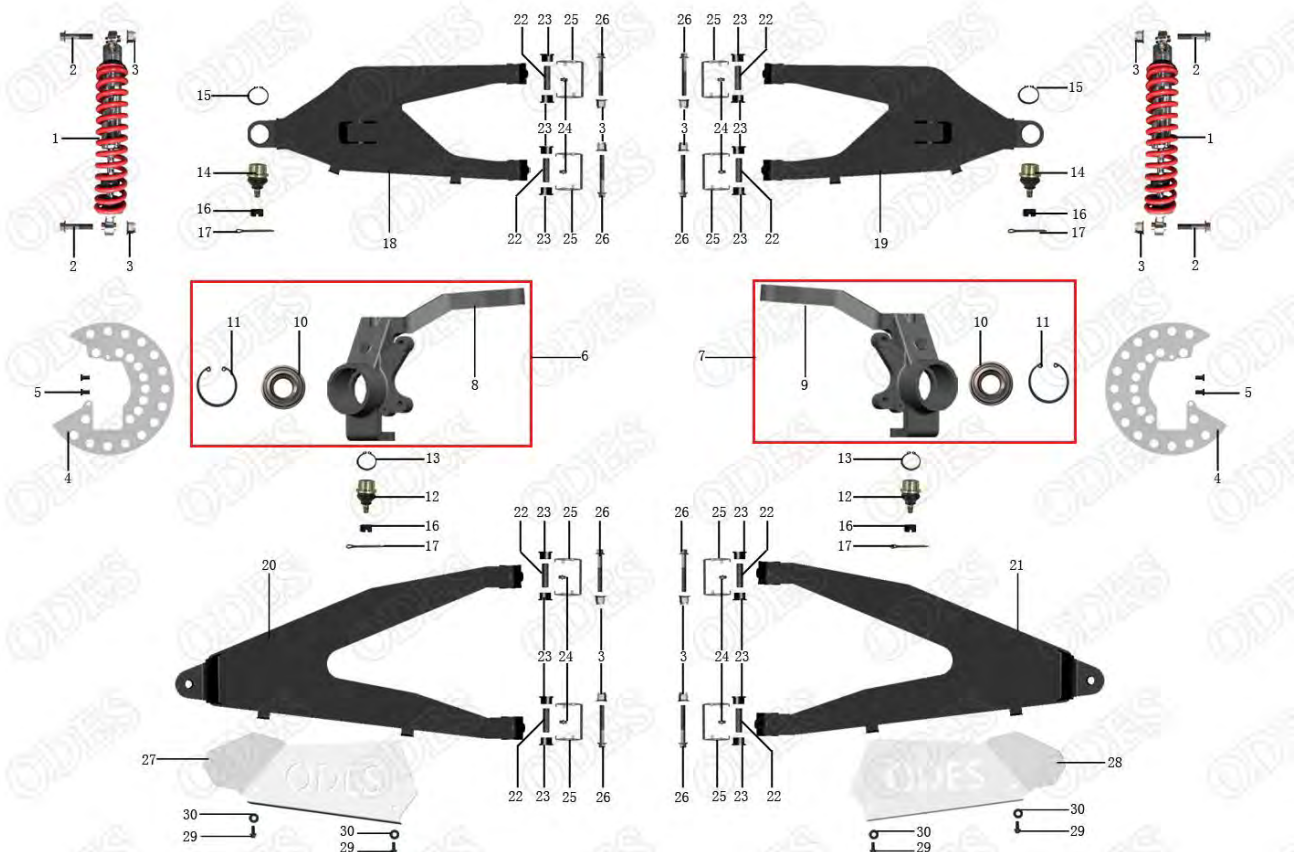

The procedure explained below is the same for the RH and LH sides unless otherwise noted. During assembly or installation, use the torque values and service products as in the torque table.

In order to prevent collapse of vehicle, please do not dismantle left and right suspensions simultaneously.

Before overhauling front suspension system, please ensure stable support of vehicle

REMOVAL AND DISASSEMBLY

Loosen wheel nut of the appropriate.

Install a jack stand under the frame to lift the front of vehicle off the ground until shock absorber is fully extended then.

Remove wheels, brake caliper and hub
remove steering knuckle from ball cage tie rod

INSPECTION

Shock absorber

Inspect the shock absorber for oil leakage or damage, inspect the bushing for wear or damage. If any damage are found, replace the front shock absorber with a new one.

Extend and compress the piston several times over its entire stroke. Check that it moves smoothly and with uniform resistance with rod up. Any of the following conditions will denote a defective shock:

- A skip or hang up when reversing stroke at mid-travel.
- Seizing or binding conditions except at extreme end of either stroke.
- A gurgling noise after completing one full compression and extension stroke.

Replace shock if any these conditions are found.

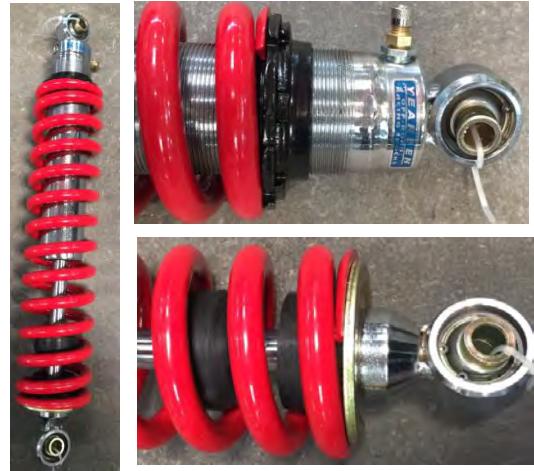

Knuckle

Inspect the knuckle for damage. If any damages are found, replace the knuckle with a new one.

Check ball joint for damage, pitting, looseness and roughness. If so ,replace it.

Check ball joint bellows for cracks. Change if necessary.



Check bearing and seal for damage or wear, If any damages or wear are found, replace a new one.

Rotate the inner race by hand to inspect for abnormal noise and smooth rotation

Lower Suspension Arm

Inspect the suspension arm and for damage or distortion. If any damages or distortion are found, replace the suspension arm with a new one.

Move suspension arm from side to side. There should be no noticeable loose. Replace bushing if necessary.

Move suspension arm up and down. There should be no noticeable loose. Replace bushing if necessary.



Upper Suspension Arm

Inspect the suspension arm and for damage or distortion. If any damages or distortion are found, replace the suspension arm with a new one.

Move suspension arm from side to side. There should be no noticeable loose. Replace bushing if necessary.

Move suspension arm up and down. There should be no noticeable loose. Replace bushing if necessary.



Check ball joint for damage, pitting, looseness and roughness. If so, replace it.

Check ball joint bellows for cracks. Change if necessary.

REASSEMBLY

Reassemble and remount the front suspension in the reverse order of removal and disassembly. Pay attention to the following points.

1. Install the washers and tighten the knuckle nuts to the specified torque.
2. Replace the removed cotter pins with new cotter pins.

REAR SUSPENSION

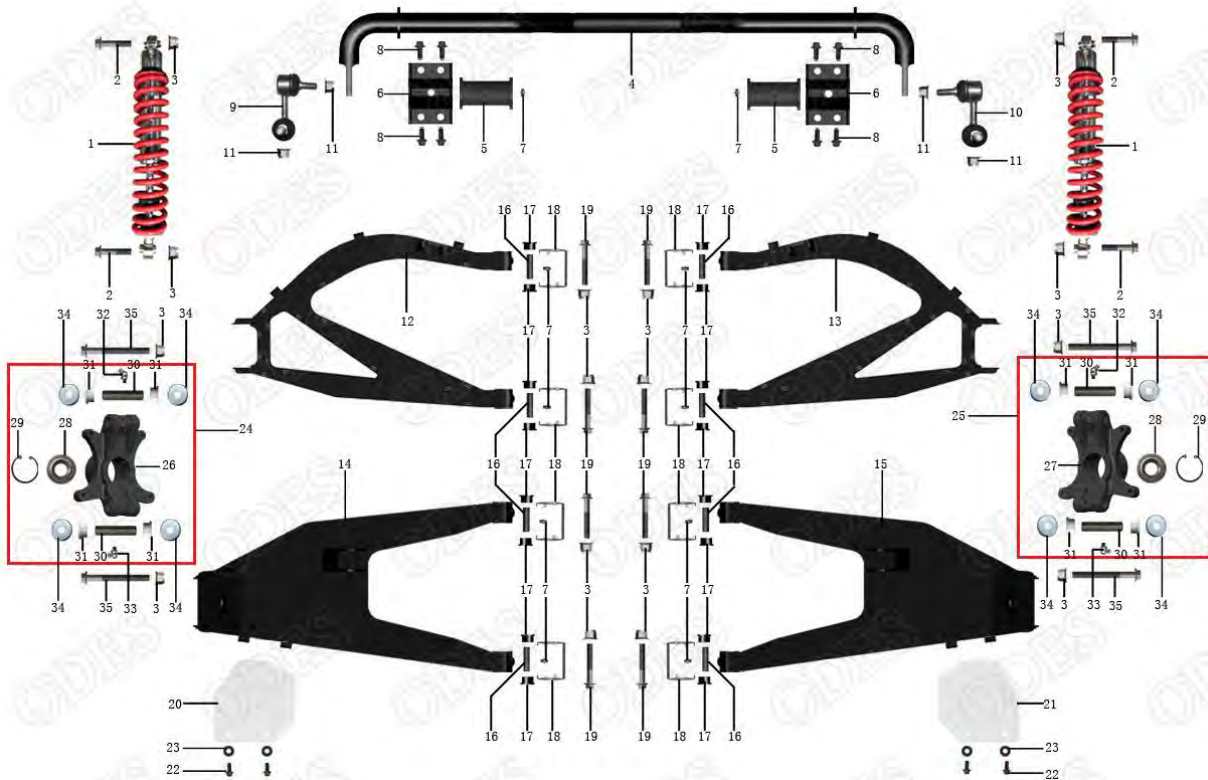

The procedure explained below is the same for the RH and LH sides unless otherwise noted. During assembly or installation, use the torque values and service products as in the torque table

REMOVAL AND DISASSEMBLY

Loosen wheel nut of the appropriate.

Install a jack stand under the frame to lift the rear of vehicle off the ground until the shock absorber is fully extended.

Remove wheels, brake caliper and hub remove steering knuckle from ball cage tie rod

INSPECTION

Shock absorber

Inspect the shock absorber for oil leakage or damage, inspect the bushing for wear or damage. If any damage are found, replace the rear shock absorber with a new one.

Extend and compress the piston several times over its entire stroke. Check that it moves smoothly and with uniform resistance with rod up. Any of the following conditions will denote a defective shock:

- A skip or hang up when reversing stroke at mid-travel
- Seizing or binding conditions except at extreme end of either stroke.
- A gurgling noise after completing one full compression and extension stroke.

Replace shock if any these conditions are found



Knuckle

Inspect the knuckle for damage. If any damages are found, replace the knuckle with a new one.



Check bearing and seal for damage or wear, If any damages or wear are found, replace a new one. Rotate the inner race by hand to inspect for abnormal noise and smooth rotation



Lower Suspension Arm

Inspect the suspension arm and for damage or distortion. If any damages or distortion are found, replace the suspension arm with a new one.



Move suspension arm from side to side. There should be no noticeable loose. Replace bushing if necessary.

Move suspension arm up and down. There should be no noticeable loose. Replace bushing if necessary.

Upper Suspension Arm

Inspect the suspension arm and for damage or distortion. If any damages or distortion are found, replace the suspension arm with a new one.



Move suspension arm from side to side. There should be no noticeable loose. Replace bushing if necessary.

Move suspension arm up and down. There should be no noticeable loose. Replace bushing if necessary.

REASSEMBLY

Reassemble and remount the rear suspension in the reverse order of removal and disassembly. Pay attention to lubricate rear knuckles with lithium-soap based grease.

9. BRAKES SYSTEM

BRAKE FLUID REPLACEMENT	9-2	BRAKE PADS REPLACEMENT	9-2
BRAKE DISC	9-3	BRAKE CALIPER	9-4
BRAKE LIGHT SWITCH	9-4	BRAKE HOSE	9-5
PARKING BRAKE MECHANISM	9-6		

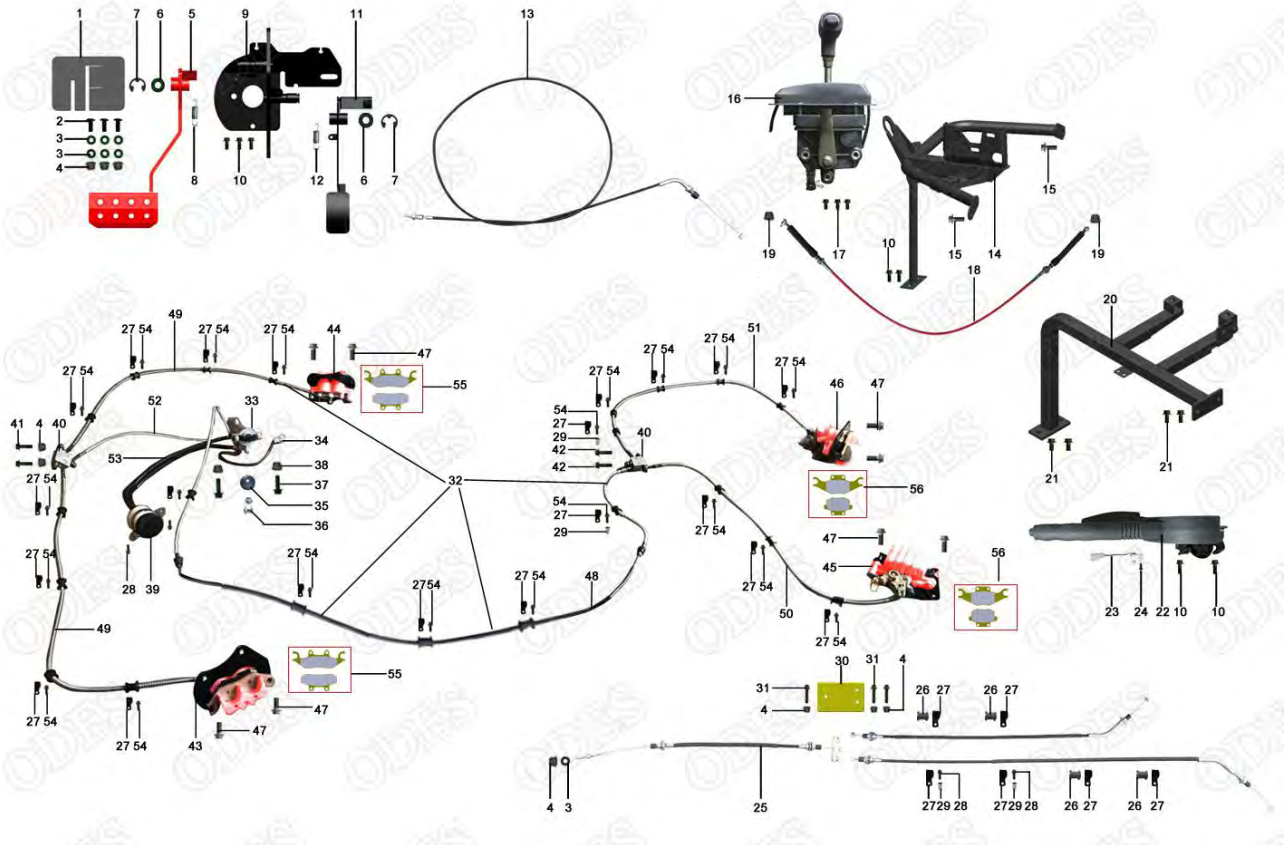

This brake system is filled with an ethylene glycol based DOT4 brake fluid. Do not use or mix different types of fluid, such as silicone-based or petroleum-based brake fluids.

Do not use any brake fluid taken from old, used or unsealed containers. Never reuse brake fluid left over from the last servicing or which has been stored for a long periods of time.

When storing brake fluid, seal the container completely and keep it away from children.

When replenishing brake fluid, take care not to get dust into fluid.

When washing brake components, use new brake fluid. Never use cleaning solvent.

A contaminated brake disc or brake pad reduces braking performance. Discard contaminated pads and clean the brake disc with high quality brake cleaner or neutral detergent.

Brake fluid may cause damage to surfaces of plastic and rubber parts. Keep it far away from these parts.

BRAKE FLUID REPLACEMENT

Place the vehicle on a level surface.
Remove the cap of brake oil cup and diaphragm.
Suck up the old brake fluid as much as possible.
Fill the reservoir with new brake fluid.



Remove the dust cap of air bleeder valve.
Connect a clear hose to the air bleeder valve and insert the other end of the hose into a receptacle.
Loosen the air bleeder valve and pump the brake pedal until the old brake fluid is completely out of the brake system.



Close the air bleeder valve and squeeze and release the brake pedal several times in rapid succession and hold the pedal fully squeezed. Loosen the air bleeder valve for about quarter of a turn so that the brake fluid runs into the receptacle, this will remove the tension of the brake pedal. Then close the bleeder valve, pump and squeeze the pedal and open the valve. Repeat this process until the fluid flowing into the receptacle contains no air bubbles.

Tighten the air bleeder valve to 6N.m.
Disconnect the clear hose and install the dust cap of air bleeder valve.

Fill the reservoir with new brake fluid to the upper edge of the inspection window.
Install the master cylinder reservoir cap and diaphragm.

CAUTION

While bleeding the brake system, replenish the brake fluid in the reservoir as necessary. Make sure that there is always some fluid visible in the reservoir.

BRAKE PADS REPLACEMENT

Remove the wheel.



Remove the brake caliper mounting bolt and brake pads mounting pins.

Remove the brake pads.

Make sure that pad spring is in position. Install the new brake pads.

Install pad pins by pushing in the pads against pad spring to align pad slots in the pads and caliper body.

Tighten the brake pad mounting pins to 18N.m.

Tighten the brake pad mounting pins to 80N.m.

CAUTION

Do not operate the brake pedal during or after brake pad removal.

Replace the brake pads as a set, otherwise braking performance will be adversely affected.

After replacing the brake pads, pump the brake pedal a few times to check for proper brake operation and then check the brake fluid level.



BRAKE DISC

Removal and disassembly

Remove the wheel.

Remove the caliper and hub.

Remove the brake disc.

Inspection

Inspect the brake disc for cracks or damage and measure the thickness using the micrometer. If any damage are found or the thickness is less than the service limit, replace the brake disc with a new one.

Minimum thickness of front brake disc: 3.5mm.

Minimum thickness of rear brake disc: 3.0mm

Measure the warpage using the dial gauge. If the warpage exceeds the service limit, replace the brake disc with a new one.

Maximum warpage of brake disc:0.3mm.

Reassembly and remounting

Reassemble and remount the brake disc in the reverse order of removal and disassembly. Pay attention to the following points:

Install the disc to the wheel hub with the punching letters on the disc showed up.

Make sure that the disc is clean and free of any greasy matter.

Apply THREAD LOCK to the brake disc bolts and tighten them to 26N.m.

BRAKE CALIPER

Removal

Loosen wheel nuts.

Raise vehicle and support it securely.

Remove appropriate wheel.

Remove the caliper bolts then the caliper. If the caliper is not being removed from the vehicle as during brake pad replacement, simply hang the caliper with a piece of wire to take the weight off the brake hose.

If the caliper is being removed for replacement, drain brake system before removing the banjo fitting and its sealing ring. Remove the caliper from the vehicle.

Catch spilled fluid with a rag. Attach the brake hose in a position to prevent the fluid from flowing out.

Disassembly

Remove brake pads.

Remove slide caliper support and pad spring.

Place rag over piston.

Place caliper body with piston down and apply small squirts of air pressure to the fluid inlet to remove piston.

Remove piston seal.

Clean piston grooves, caliper cylinder and piston with clean brake fluid.

Clean slide pins with brake cleaner and a rag.

Inspection

If boots are deteriorated or hard, replace with new ones.

Check caliper cylinder for scratches, rust or other damages. If so, replace caliper.

Check piston for scratches, rust or other damages. If so, replace caliper.

Assembly

Coat piston seal with clean brake fluid and install it into piston grooves in caliper.

Coat piston with clean brake fluid and install into cylinder with the closing toward caliper body.

Apply dielectric grease into sliding bores and install slide pins.

Install pad spring, caliper bracket and pads.

Installation

For installation, reverse the removal procedure, pay attention to the following details:

Use new sealing washers when installing banjo fitting retaining brake hose to caliper.

Install caliper in its original position.

Bleed the brake system

Check for leaks and make sure the brakes operate normally before driving.

BRAKE LIGHT SWITCH

The brake light switch is located on the brake master cylinder. It can not be adjusted.

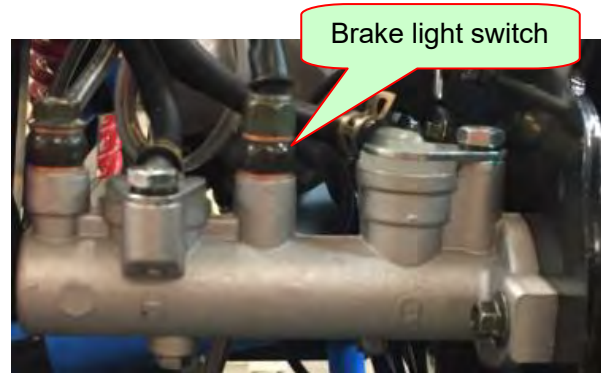

Inspection

Fist ensure brake light is good.
 Check switch for dirt or corrosion. Make sure it is operating properly.
 Depress brake pedal and check for brake light to turn on. Repeat with the brake pedal.

Test

Disconnect switch connectors.
 Check switch operation as follows.

SWITCH POSITION	PIN		RESISTANCE
Firmly pushed	1	2	0.2Ωmax
Released			Infinite

If switch is defective, replace with a new one.
 If switch tests good, check wiring harness.

Remove

Disconnect switch connectors.
 Drain brake system.
 Unscrew brake light switch from master cylinder.
 Catch spilled fluid with a rag.

Installation

For installation,reverse the removal procedure.
 Bleed the brake system
 Check for leaks and make sure the brakes operate normally before driving.



BRAKE HOSE

Inspection

Brake hose should be inspected frequently for leaks an damages.
 Check if the hoses are crushed or damaged. Any deformation can restrict the proper flow of fluid and cause braking problems.
 Check hoses for cracking scrapes. This damage can cause hose failure under pressure.
 When hoses are removed or disconnected, cleanliness must be observed. Clean all joints and connections before disassembly. New hoses should be cleaned with brake fluid before installation to remove any contamination.
 Replace any defective parts.

Removal

Before removing any hoses, drain brake system.
 Remove all necessary parts to reach the hoses.
 Thoroughly clean the area around the joints that will be disconnected.
 Place a pan under the joint that will be disconnected.
 Disconnect any retaining clips or brackets holding the hose and remove the defective parts.

Installation

Install the new hose.

Make sure the piece will not rub against any other part.

When there is a banjo fitting securing the hose to the caliper or to the master cylinder, always replace the sealing washers with new ones.

Install any retaining clips or brackets.

Refill and bleed the brake system.

Check for leaks and make sure the brakes operate normally before driving.

PARKING BRAKE MECHANISM

Parking brake cable removal

Remove left and right seats, gear shift handle.

Remove engine shield.



Detach parking brake cable from pulley as follows:

Ensure parking brake is released.

Unscrew nut securing parking brake cable on parking brake support.

Remove cable from parking brake support.

Unhook cable from pulley.



Remove parking brake cable fasteners from junction box fixing plate



Remove cable from L/R zipper rockers



Parking brake cable installation

The installation is the reverse of the removal procedure.

However, pay attention to the following.

Parking brake cable through frame under the cargo bed from left to right.

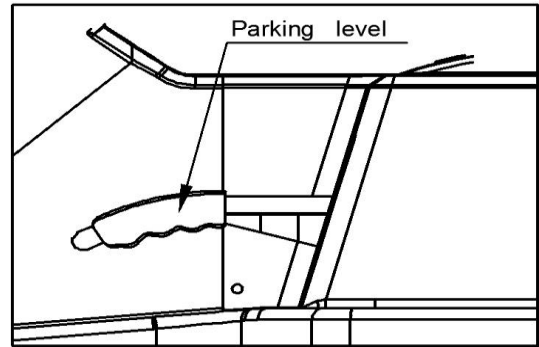

Adjust parking brake cable. Pull the parking brake lever up to engage the parking brake. To release the unit, press button on front end of parking lever then push the parking lever to the bottom.

The free play is 15~20mm, the travel is 7 teeth.



If necessary, slacken the cable by loosening the locknut and screwing the adjuster on the brake holder. After adjusting the play, tighten the locknut. Or screwing the adjustment nut on the parking brake caliper

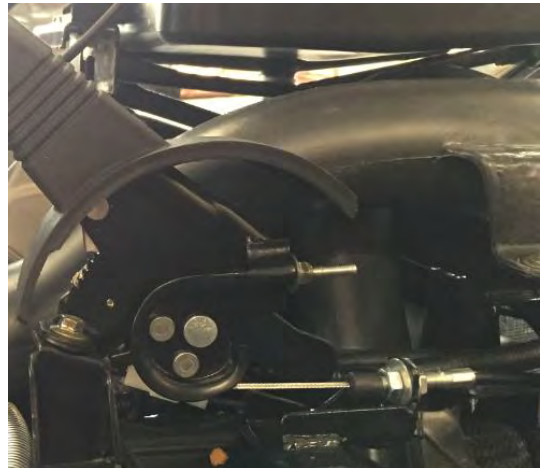

10. ELECTRICAL SYSTEM

WIRING10-1	CHARGING SYSTEM.....10-2
STARTING SYSTEM.....10-4	IGNITION SYSTEM.....10-7

Warning

- ◁ Bulb will be very hot after turning on headlamp. Please do not touch it immediately after its off. In operation, bulb needs to be cooled.
- ◁ In warning inspection of water temperature, fire or high temperature liquid may be needed. Keep it far away from inflammable and do not to be burnt.
- ◁ The temperature will be very high in turning of headlamp. For replacement, grease dirt will be splashed to glass in case of operation with bare hands or wearing dirty gloves. As a result, hot spots and glass deformation may be caused with damage to bulb as well.
- ◁ Pay attention to the following in replacing bulb:
 - Do not replace bulb when it is on. Turn off ignition switch and replace it after cooling bulb.
 - In order to avoid splashing grease to glass, wear clean gloves in replacing bulb.
 - Use cloth with alcohol or banana water to clean glass to prevent any grease sticking to glass.
- ◁ Check battery to confirm whether it is normal.
- ◁ Regularly check switch and do not dismantle it from vehicle in inspection.
- ◁ Cables and wires of each part need to be arranged reasonably.

power supply system

Removal and installation of battery

- 1、 Open the hood
- 2、 Remove 3 plastic buttons on the top cover of the battery box;
- 3、 Use appropriate tools to loosen the positive and negative clamps of the battery connection post and remove the positive and negative connection post from the battery connection post;
- 4、 Remove the battery from the battery box



Fuse Application

After determining the cause of the burn and troubleshooting, replace the broken fuse with a specified type of fuse. If no troubleshooting is done before replacement, the fuse may be burned again.

Removal/installation of main fuse

- 1、 Remove battery negative connection.
- 2、 Remove the main fuse box cover.
- 3、 Disassemble in the order specified in the table。
- 4、 Installation sequence is opposite to disassembly sequence。

Remove/install fuse box

- 1、 Remove battery anode connection。
- 2、 Remove self-tapping nail for fixing fuse box。
- 3、 Installation sequence is opposite to disassembly sequence。

○ — ○ Conduction

Ignition switch position	Terminals			
	A	B	C	D
OFF				
ACC	○ — ○			
ON	○ — ○ — ○			
start-up		○ — ○ — ○		

Inspection of ignition switches

- 1、 Remove battery negative connection.
- 2、 Open hood cover.
- 3、 Disconnect ignition switch connector.
- 4、 Check the conduction between the terminals of the ignition switch with an ohmmeter and replace the ignition switch if it does not meet the technical requirements renewal

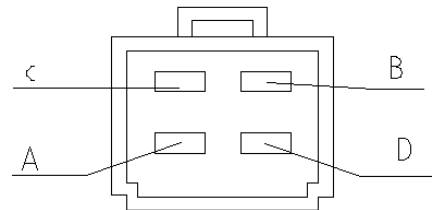

Inspection of backup power

- 1、 Open hood cover
- 2、 Disconnect the backup power connector.
- 3、 Use a voltmeter to check the wire harness end 12 voltage.

exterior lighting system

Removal and Installation of Front Combined Headlamps

- 1、 Remove the positive and negative connection of battery。
- 2、 Open front hood。
- 3、 Disassemble (1, bolt ;2, nut ;3, combined headlamp ;
- 4、 plug-in) in sequence as shown.

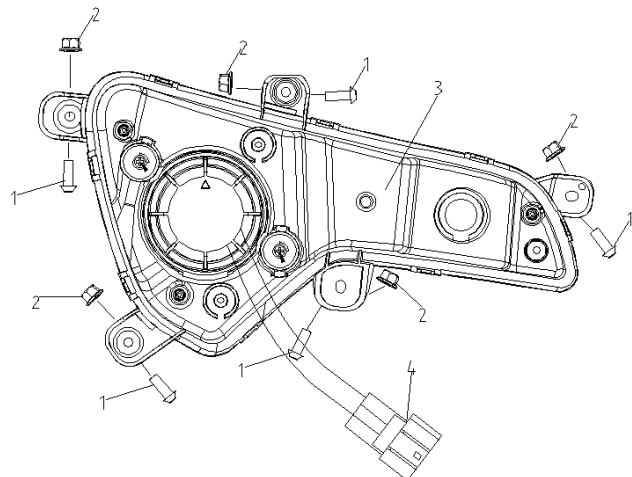

pay attention to:

- 1、 Halogen bulbs produce a lot of heat when used, if the surface of the bulb is dirty, heat will continue to accumulate to shorten the service life of the bulb, when changing the bulb to hold the metal flange rather than glass. The ohmmeter can be used to detect the resistance of the bulb, the resistance is infinite or 0 to replace the bulb or lamp combination;
- 2、 Front position lamp and front turn lamp are LED lamp band structure, can use ohmmeter to detect bulb resistance, resistance infinity or 0 replacement lamp combination

Removal and installation of light control switches

- 1、 Remove the positive and negative connection of battery。
- 2、 Open hood cover。
- 3、 Disconnect headlight switch connector。
- 4、 Push the switch out of the back of the meter。
- 5、 Check the conductivity between the ignition switch
Terminals with an ohmmeter and replace the switch
if it does not meet the technical requirements

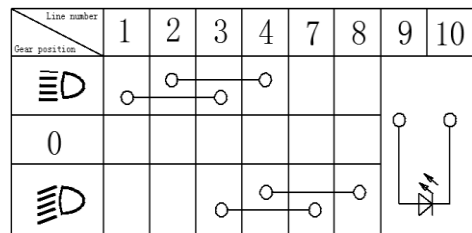

Removal and installation of steering light control switches

- 1、 Open hood cover。
- 2、 Disconnect steering light or four-flash switch connector。
- 3、 Push the switch out of the back of the meter。
- 4、 Check the conductivity between the ignition switch
terminals with an ohmmeter and replace the headlamp
if it does not meet the technical requirements。

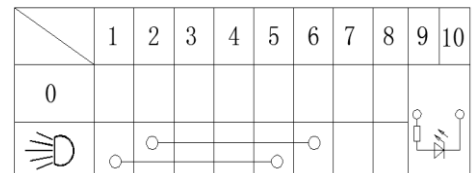
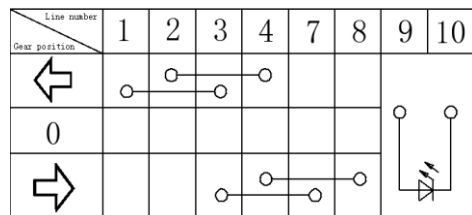

Removal and Installation of Top Lamps

- 1、 Remove the positive and negative connection of battery。
- 2、 Disconnect the positive power supply connected to the top lamp。
- 3、 Disassemble (1, bolt ;2, top lamp) in the sequence shown in the diagram
- 4、 The order of installation is contrary to the order of disassembly

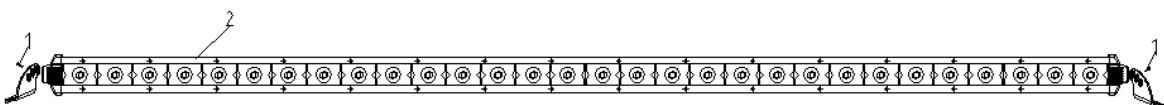

Removal and Installation of Top Lamp Control Switch

- 1、 Open hood cover。
- 2、 Disconnect headlamp switch connector。
- 3、 Push the switch out of the back of the meter。
- 4、 Check the conductivity between the ignition switch terminals with an ohmmeter and replace the switch if it does not meet the technical requirements。

	1	2	3	4	5	6	7	8	10
0						○	○		
	○	○	○	○	○	○	○		○

Removal and installation of horn

- 1、 Disconnect horn plug。
- 2、 Disassemble (1, bolt ;2, horn) in sequence shown in the diagram。
- 3、 The order of installation is contrary to the order of disassembly。

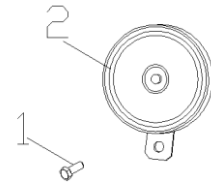

Removal and installation of horn control switches

- 1、 Open hood cover。
- 2、 Disconnect horn switch。
- 3、 Push the switch out of the back of the meter。
- 4、 Check the conductivity between the ignition switch terminals with an ohmmeter and replace the switch if it does not meet the technical requirements。

	1	3	5	6	9	10
0					○	○
	○	○			○	○

Removal and Installation of Electric Top

- 1、 Box raised。
- 1、 Disconnect the electric ceiling。
- 2、 Disassemble (1, open pin ;2, upper fixed pin ;3, open pin ; 4, lower fixed pin ;5, electric top) in sequence as shown.
- 3、 The resistance value of electric top resistor can be detected by using ohmmeter. The resistance is infinite or the electric top can be replaced by 0

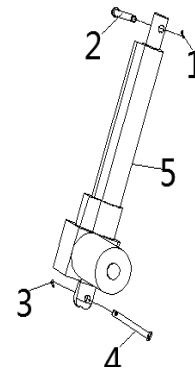

Removal and Installation of Electric Top Switch

- 1、 Disconnect electric top switch plug-in。
- 2、 Remove the electric top switch from the rear body guard。
- 3、 Use ohmmeter to check the conduction between the ignition switch terminals, if not meet the technical requirements to replace the switch;

	1	2	3	4	7	8	9	10
DOWN	○	○	○	○				
0							○	○
UP			○	○	○	○		○

Removal and installation of instrumentation

- 1、 Open the hood cover。
- 2、 Remove the nut of the fixed instrument using the appropriate tool。
- 3、 Disconnect instrument plug。

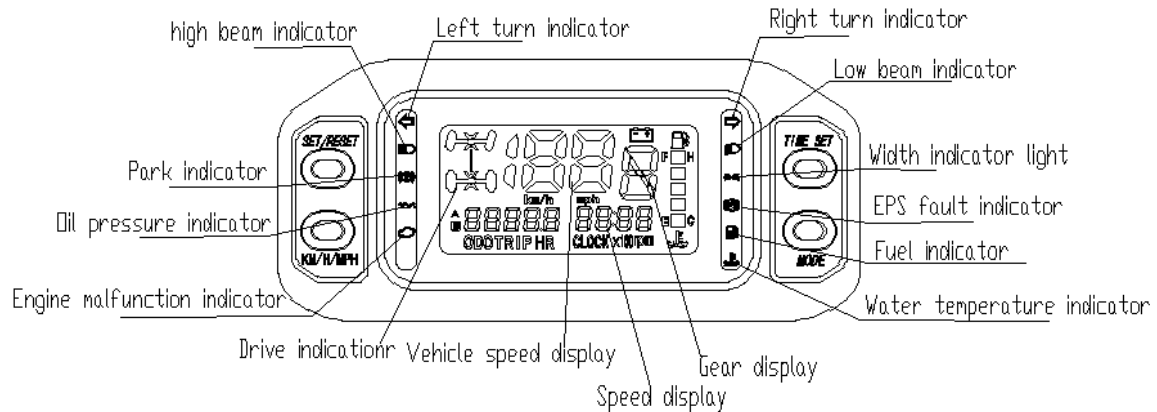
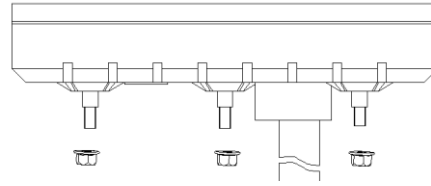

Instrument Display Function Information

- 1、 A left steering light 12 V positive is effective; the left steering light flashes at the same frequency when the vehicle turns on。
- 2、 FFar light indicator light 12 V positive very effective light, after the far light turned on this indicator light at the same time
- 3、 A parking indicator light of 12 V is effectively on the negative pole. After the stop of the vehicle is pulled up, the indicator lights up and the indicator lights out after the stop is released
- 4、 Oil pressure switch alarm indicator lamp 12 negative effective light, after the engine operation oil pressure alarm indicator lights out, engine operation when this indicator light is still on, indicating that the engine lubrication system may not be normal;
- 5、 A right steering indicator light 12 V is very effective; the indicator lights flicker at the same frequency when the vehicle turns on the left steering light
- 6、 A near-light indicator light of 12 V is very effective. When the near-light light is turned on, the indicator lights up at the same time
- 7、 A width indicator lamp of 12 V is effective. When the near-light is turned on, the indicator lights up at the same time.
- 8、 EPS the fault indicator light is effectively on the ground, the alarm indicator light EPS extinguished after the engine is running, and the indicator light is still on when the engine is running, it means that the EPS system may not be normal, can check whether the speed signal is normal, whether the controlled power input is normal, and whether the input positive pole of the steering booster head is normal.

9、 The fuel alarm indicator lamp, there are two coils in the fuel meter, respectively on the F and E side, the sensor is a variable resistance controlled by the float height, the change of resistance value determines the strength of the magnetic force line of the two coils, and also determines the display value of the oil level。

Turn off the ignition switch and disconnect the connector and use the ohmic gear to measure the resistance

Lower: Blue/white :3-9Ω

Higher: blue/white :90Ω

If the resistance is not in the range of null and full value, replace the fuel pump. If the fuel level sensor is good, please find the line or meter.



10、 The water temperature alarm indicator lamp, the sensor of the water temperature meter is a kind of thermistor type sensor, the signal comes from the coolant temperature sensor at the engine cylinder head;

11、 The speedometer obtains the signal from the speed sensor on the gearbox and displays the number through the change of pulse frequency.

12、 The tachometer works according to the magnetic principle. it receives the pulse signal generated when the primary current is interrupted in the ignition coil and converts this signal to the displayable speed value. the faster the engine speed, the more pulse times the ignition coil produces, the greater the rotational speed value displayed on the table.

13、 Engine fault indicator lamp, after engine operation fault alarm indicator lamp extinguished, engine operation this indicator lamp is still on, engine operation may not be normal, can use the old, fault diagnostic instrument to detect the fault code of the engine, fault code refers to the self-diagnosis system detected fault or fault.

open the hood upper cover and look for the harness connector

of the fault diagnosis tester next to the ECU.

Unplug the protector and connect the fault diagnosis tester with special data line.

Open the fault diagnosis tester and read the fault code.



10. ELECTRICAL SYSTEM

DTC Number	System or Component	DTC Description	Related Calibration
P0107	Manifold Absolute Pressure Sensor (MAP)	MAP Circuit Low Voltage or Open	KsDGDM_MAP_ShortLow
P0108		MAP Circuit High Voltage	KsDGDM_MAP_ShortHigh
P0112	Intake Air Temperature Sensor (IAT)	IAT Circuit Low Voltage	KsDGDM_IAT_ShortLow
P0113		IAT Circuit High Voltage or Open	KsDGDM_IAT_ShortHigh
P0117	Coolant/Oil Sensor	Coolant/Oil Temperature Sensor Circuit Low Voltage	KsDGDM_CoolantShortLow
P0118		Coolant/Oil Temperature Sensor Circuit High Voltage or Open	KsDGDM_CoolantShortHigh
P0122	Throttle Position Sensor (TPS)	TPS Circuit Low Voltage or Open	KsDGDM_TPS_ShortLow
P0123		TPS Circuit High Voltage	KsDGDM_TPS_ShortHigh
P0131	Oxygen Sensor	O2S 1 Circuit Low Voltage	KsDGDM_O2_1_ShortLow
P0132		O2S 1 Circuit High Voltage	KsDGDM_O2_1_ShortHigh
P0032	Oxygen Sensor Heater	O2S Heater Circuit High Voltage	KsDGDM_O2_HeaterShortHigh
P0031		O2S Heater Circuit Low Voltage	KsDGDM_O2_HeaterShortLow
P0201	Fuel Injecto	Injector 1 Circuit Malfunction	KsDGDM_INJ_CYL_A_Fault
P0202		Injector 2 Circuit Malfunction	KsDGDM_INJ_CYL_B_Fault
P0230	Fuel Pump Relay (FPR)	FPR Coil Circuit Low Voltage or Open	KsDGDM_FPP_CircuitShortLow
P0232		FPR Coil Circuit High Voltage	KsDGDM_FPP_CircuitShortHigh
P0336	Crankshaft Position Sensor (CKP)	CKP Sensor Noisy Signal	KsDGDM_CrankNoisySignal
P0337		CKP Sensor No Signal	KsDGDM_CrankNoSignal
P0351	Ignition Coil	Cylinder 1 Ignition Coil Malfunction	KsDGDM_EST_A_Fault
P0352		Cylinder 2 Ignition Coil Malfunction	KsDGDM_EST_B_Fault
P0505	Idle Control System	Idle Speed Control Error	KsDGDM_IdleControl
P0562	System Voltage	System Voltage Low	KsDGDM_SysVoltLow
P0563		System Voltage High	KsDGDM_SysVoltHigh
P0650	MIL	MIL Circuit Malfunction	KsDGDM_MIL_Circuit
P1693	Tachometer	Tachometer Circuit Low Voltage	KsDGDM_TAC_Circuit_Low
P1694		Tachometer Circuit High Voltage	KsDGDM_TAC_Circuit_High
P0137	Oxygen Sensor 2	O2S 2 Circuit Low Voltage	KsDGDM_O2_2_ShortLow
P0138		O2S 2 Circuit High Voltage	KsDGDM_O2_2_ShortHigh
P0038	Oxygen Sensor Heater 2	O2S Heater 2 Circuit High Voltage	KsDGDM_O2_HeaterShortHigh
P0037		O2S Heater 2 Circuit Low Voltage	KsDGDM_O2_HeaterShortLow
P0500	Vehicle Speed Sensor	VSS No Signal	KsDGDM_VSS_NoSignal
P0850	Park Neutral Switch Diag	Park Neutral Switch Error	KsDGDM_ParkNeutralSwitch
P0445	CCP	CCP short to high	KsDGDM_CCP_CircuitShortHigh
P0444		CCP short to low/open	KsDGDM_CCP_CircuitShortLow

STARTING SYSTEM

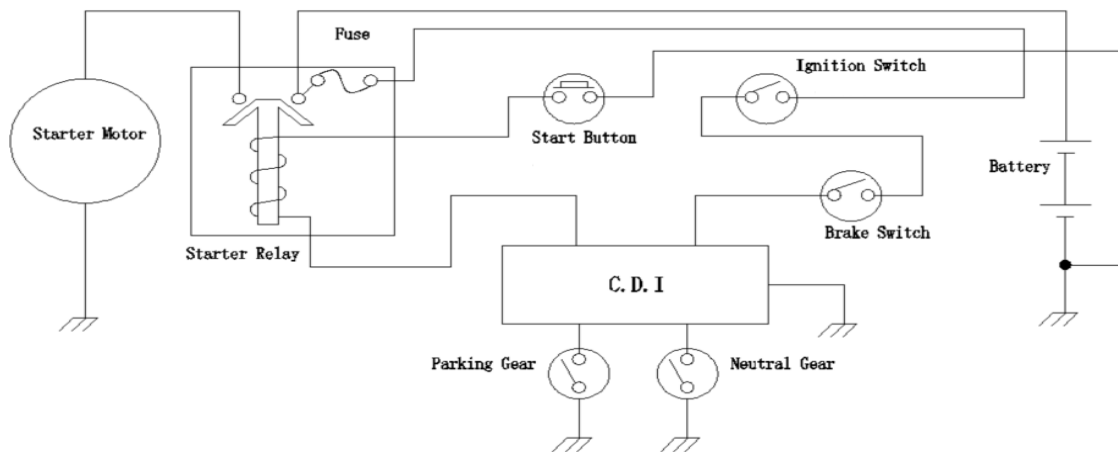

Starter motor

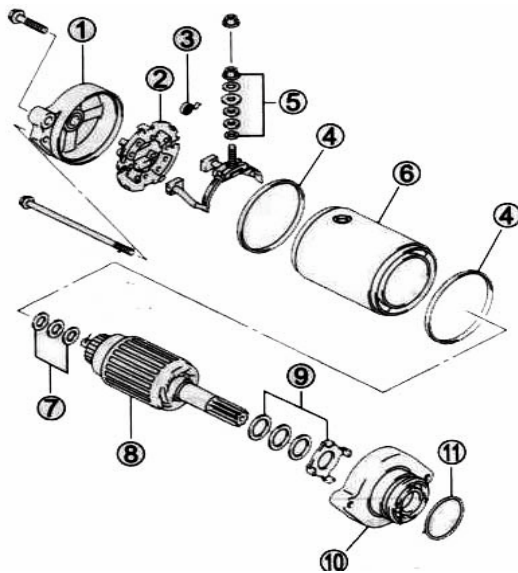

- ① Bracket
- ② Brush Seat
- ③ Brush Spring
- ④ O-ring
- ⑤ Shims
- ⑥ Motor Housing
- ⑦ Washers
- ⑧ Armature Coil
- ⑨ Washer Kit
- ⑩ Inner Bracket
- ⑪ O-ring

Brush

Z Check the brush on the brush holder whether it is worn abnormal, cracked or not smooth.

Worn, cracked, or not smooth: → Replace

Rectifier

Z Check the rectifier whether it is discolored, abnormal wear or concave.

Abnormal wear or damage: → Replace

Z If the rectifier is discolored, grind it with sanding paper, then wipe it with a clean fabric.

Z If there is concave, scrape off insulator B, so that the distance with A is d.

d≥1.5mm

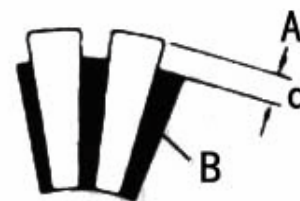

Armature coil

- Z Test the connection between each wire and the armature coil with the multimeter.
- Z If they are not connected, replace the armature shaft.

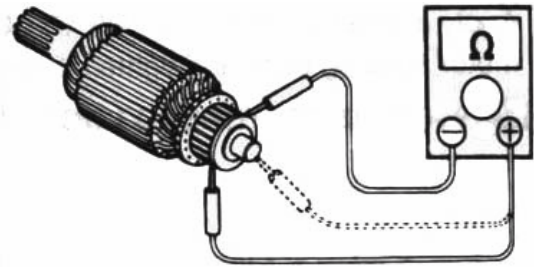

Oil seal

- Z Check the oil seal lip for damage or leak.

Damage or leakage: →Replace the starter motor.

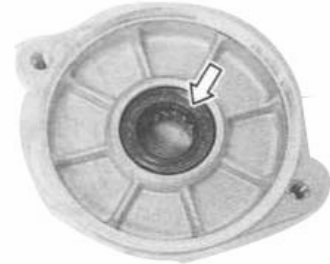

Starter relay

- Z Inter-terminal voltage is 12V. Test the direct connection of positive and negative poles with the multimeter.
- Z If the starter relay clicks and connected, the starter relay is OK.
- Z When there is no voltage of 12V, they are not connected, the starter relay is OK.

Note: Do not apply battery voltage on the starter relay for more than 2 seconds. This will result in overheating or damaging the relay coil.

- Z Measure the coil resistance with the multimeter. If the resistance exceeds the specified value, replace the starter relay.

The multimeter is set to 1x10Ω.

Starter relay coil resistance: 3-5Ω

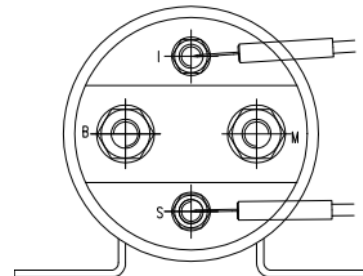
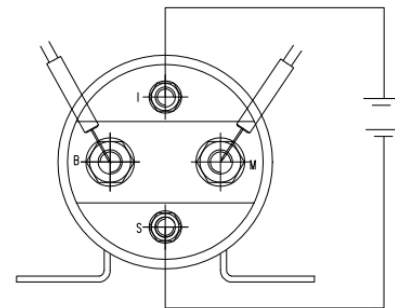

Auxiliary starter relay

- Z Apply 12V voltage between the positive and negative terminals of the starter relay. Test the connection between A and B with the multimeter.
- Z If the starter relay clicks and is connected, the starter relay is OK.
- Z When there is no voltage of 12V, they are not connected, the starter relay is OK.

The multimeter is set to 1x10Ω.

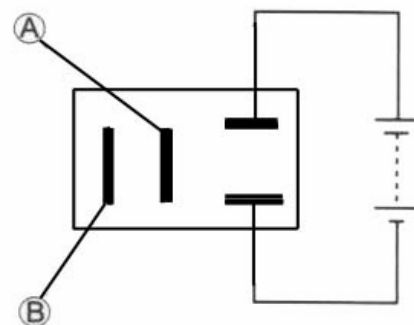

Auxiliary starter relay coil resistance: 90-100Ω

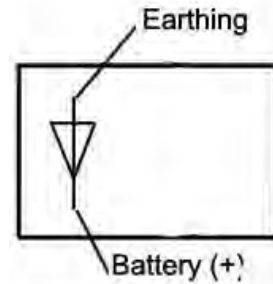

IGNITION SYSTEM

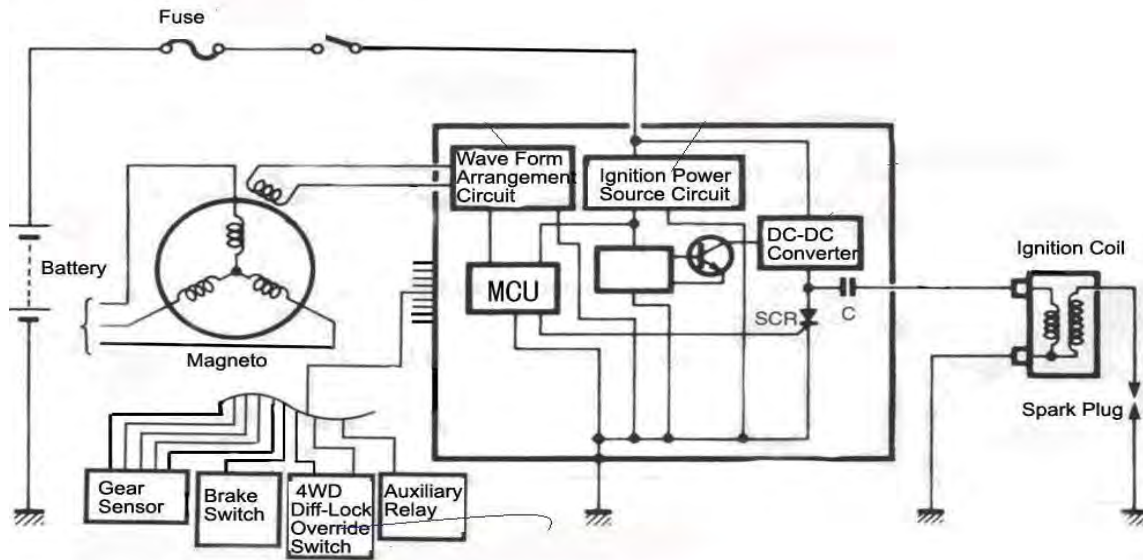

Ignition coil

Primary peak voltage of ignition coil

Z Remove the spark plug cap as shown in the right figure. Install the new spark plug to the cap. The cylinder is connected to grounding.

Z Connect the multimeter and the peak voltage adapter as follows:

+Probe: Green wire or grounding wire

-Probe: Black / yellow wire

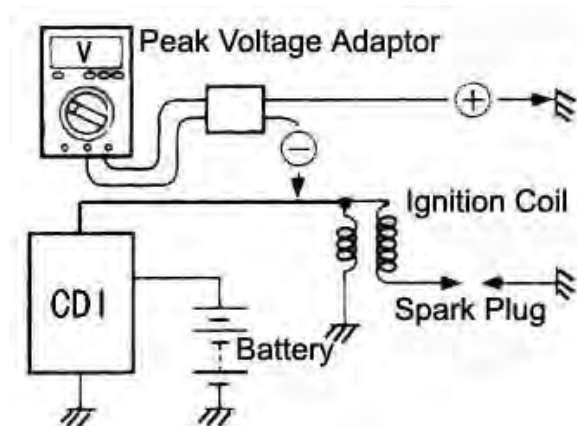

NOTE:

- Z Make sure the battery voltage $\geq 12V$. The ignition coil wires are connected.
- Z When using multimeter and the peak voltage adapter, please refer to the user manual.
- Z Move the gear to the neutral position, turn on the ignition device.
- Z Press the start button and crank the engine for a few seconds. Then measure the primary peak voltage of the ignition coil;
- Z Repeat the steps above for several times. Measure the maximal value of the primary peak voltage. Set the multimeter at the AC voltage position.

Primary peak voltage of ignition coil: $\geq 150V$

Note: Do not touch the test probes or spark plug, in case of electric shock.

- Z If the voltage is lower than the standard value, check the ignition coil and coupling coil.

Resistance of ignition coil

- Z Disconnect the ignition coil wires and spark plug cap. Remove the ignition coil;
- Z Measure the resistance of the primary and secondary windings of the ignition coil with the multimeter. If the resistance of two coils is close to the specified value, the ignition coil is in good condition.

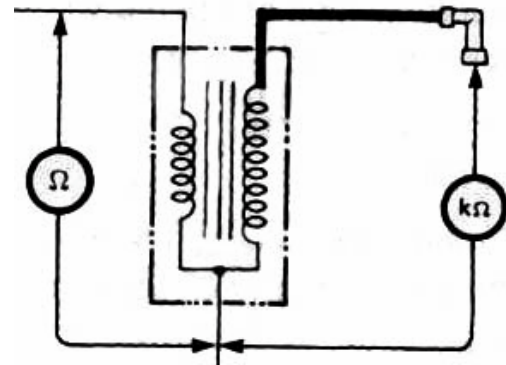

Resistance of ignition coil

Primary winding: 0.1-1.5 Ω (terminal - ground)

Secondary coil: 12-22KΩ (terminal - spark plug cap)

Peak voltage of coupling coil

- Z Check the peak voltage of the coupling coil with following steps.
- Z As shown in right figure, connect the multimeter with the peak voltage adapter.

+Probe: Green wire

-Probe: Blue wire

- Z Move the gear to the neutral position, turn on the ignition device.
- Z Press the start button and crank the engine for a few seconds, and then measure the primary peak voltage of the coupling coil;
- Z Repeat the steps above for several times. Measure the maximal value of the primary peak voltage.

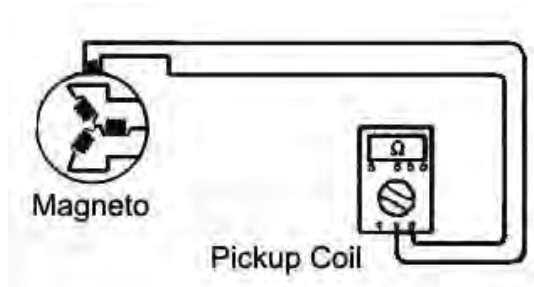
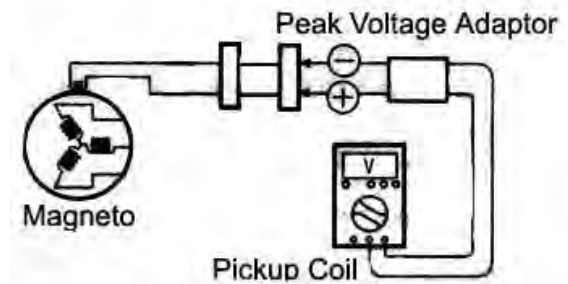

Put the multimeter at AC voltage step.

Peak voltage of coupling coil: $\geq 4V$

- Z If the voltage is lower than the standard value, replace coupling coil.

Resistance of coupling coil

The multimeter is put at 1x100Ω step.

Resistance of coupling coil: 120-130Ω

- Z If the resistance is not within the specified value, replace the coupling coil.

CHARGING SYSTEM

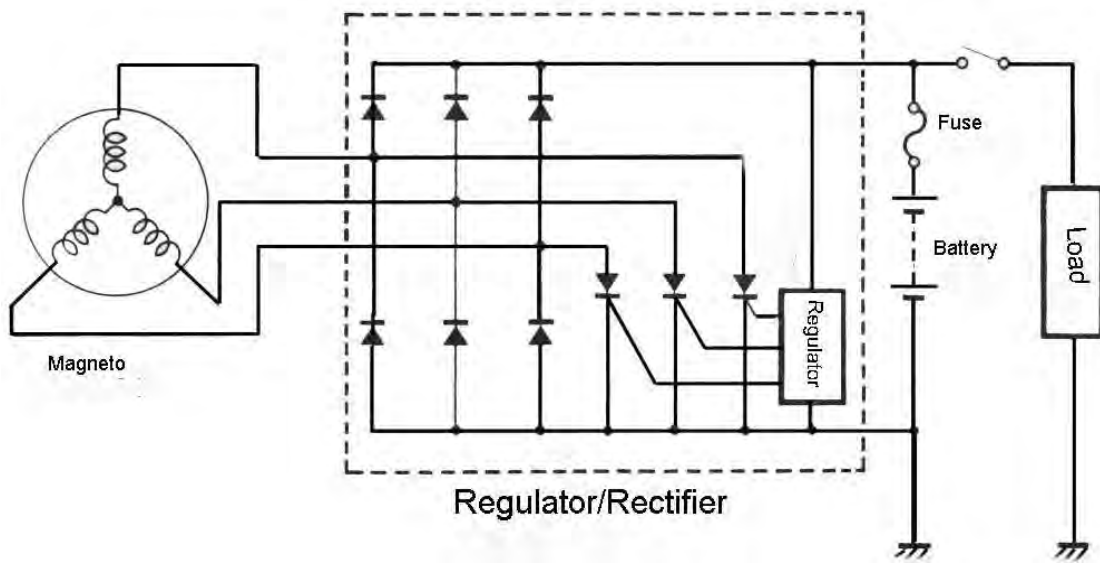

Resistance of generator coil

- Z Measure the resistance between three wires;
- Z If the resistance is not within the specified value, replace the stator coil.
- Z Check the generator core whether it is insulated. Install multimeter 1×10Ω.

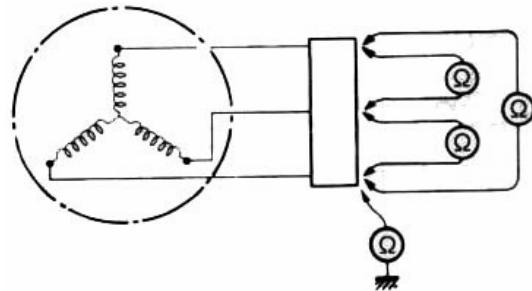

Resistance of generator coil: 0.9-1.5Ω (color: yellow)

Insulation resistance ∞Ω (yellow - grounding wire)

No- load performance of the generator

- Z Start the engine with the speed at 5000r/min.
- Z Measure AC voltage three wires inside the generator with the multimeter.
- Z If the voltage drops below a specified value, replace the generator.

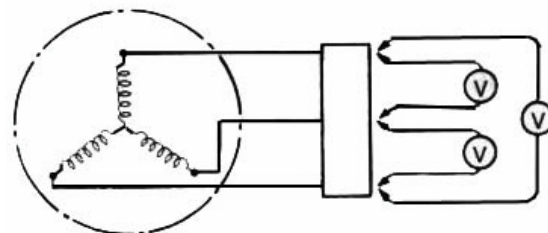

Put the multimeter at AC step.

No- load performance of the generator: > 200V (AC) at 5000r/min

Regulator / Rectifier

- Z Measure the resistance between terminals with multimeter.
- Z If the resistance is not within the range of specified values, replace the regulator / rectifier.

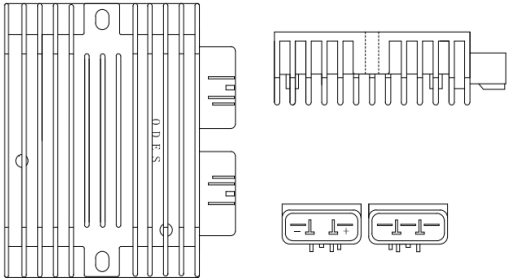

NOTE:
 If the probe is not connected and the multimeter reading is lower than 1.4V, replace the multimeter battery.

	Red ⊕						
Black ⊖		Yellow	Yellow	Yellow	Green	Red	Black
	Yellow	∞	∞	∞	400-500	∞	∞
	Yellow	∞	∞	∞	400-500	∞	∞
	Yellow	∞	∞	∞	400-500	∞	∞
	Green	∞	∞	∞	∞	∞	∞
	Red	400-500	400-500	400-500	750-850	∞	∞
	Black	∞	∞	∞	∞	∞	∞

11. TROUBLESHOOTING

ELECTRICAL SYSTEM.....	11-1	COOLING SYSTEM.....	11-1
MAGNETO SYSTEM.....	11-2	LUBRICATION.....	11-3
CYLINDER AND HEAD.....	11-4	CRANKSHAFT.....	11-5
GEARBOX.....	11-5	COUPLING UNIT.....	11-6
CVT.....	11-7	ENGINE GENERAL.....	11-10
FAULT CODES.....	11-13		

ELECTRICAL SYSTEM

Symptom: NO SPARK OR POOR SPARK

1. Refer to ignition system.

Symptom: STARTER DOES NOT TURN

1. Refer to starting system.

Symptom: STARTER TURNS BUT DOES NOT CRANK THE ENGINE

1. Refer to starting system.
2. Check gear condition on electric starter.
 - Worn and/or damaged starter gear. Replace electric starter and/or starter drive.
3. Check condition of starter pinion gear.
 - Worn and/or damaged starter pinion and/or ring gear. Replace starter drive and/or drive pulley fixed sheave.
4. Check splines on starter drive.
 - Poor movement of pinion gear on splines. Clean and/or replace starter drive.

Symptom: STARTER TURNS BUT STARTER DRIVE DOES NOT MESH WITH RING GEAR

1. Refer to starting system.

Symptom: STARTER KEEPS RUNNING

1. Refer to starting system.

COOLING SYSTEM

Symptom: HIGH ENGINE OPERATING TEMPERATURE

1. Check coolant level.
 - Coolant level lower than recommended. Refill(refer to cooling system).
2. Check mud/dust in radiator fins.
 - Radiator fin obstructed, hard air cooling. Clean radiator fins.
3. Check cooling fan and connection(must all fan can work).
 - Fan motor faulty. Replace.
 - Wire harness is brittle or hard (no connection). Replace.
4. Check radiator fan switch and fuse.
 - Faulty fan switch and/or faulty fuse. Replace defective part(s).
5. Check radiator condition for leakage.
 - Radiator cracked or deformed. Replace radiator.

6. Check for air bubbles in cooling system.
 - Air in cooling system. Refill and bleed cooling system (refer to cooling system).
7. Check temperature sensor for electrical/mechanical failure.
 - Temperature sensor defective. Replace.
8. Check thermostat.
 - Thermostat defective (does not open when engine gets hot). Replace (refer to cooling system).
9. Check leak indicator hole (in crankcase MAG side-water pump housing area) if coolant leaks.
 - Coolant leaking from indicator hole means a damaged water pump rotary seal. Replace rotary seal (refer to cooling system)..
10. Check condition of hoses and hose clamps fixation.
 - Hoses are brittle and/or hard. Replace.
 - Hose clamps are loose. Retighten clamps.
11. Check condition of impeller located on the water pump shaft.
 - Impeller wings broken and/or impeller threads are damaged. Replace (refer to cooling system).
12. Check gasket on water pump housing.
 - Gasket on water pump housing leaks. Retighten screws and/or replace gasket.
13. Check cylinder head and/or cylinder base gasket.
 - Worn out gasket(s) is (are) causing coolant leakage. Replace.
14. Check coolant drain screw on water pump housing MAG side.
 - Copper ring on drain screw leaks. Retighten screw and/or replace copper ring.
15. Check intermediate gear(s) behind of PTO cover.
 - Worn out and/or broken gear(s) is/are causing less coolant supply. Replace worn out and/or broken gear(s) (refer to bottom end).
16. Check if water pump shaft is seized.
 - Water pump shaft does not turn. Replace defective part(s).

MAGNETO SYSTEM

Symptom: BATTERY NOT CHARGING OR CHARGING VOLTAGE INADEQUATE

1. Check battery
 - Battery shows less power. Reload battery.
2. Check magneto for damage and/or electrical failure.
 - Radial position of rotor wrong due to broken woodruff key. Replace woodruff key.
 - Coating on stator winding is damaged. Replace stator.
 - Resistance value is out of specification (refer to technical specifications). Replace magneto.
 - Connector on magneto is damaged and/or has electrical failure. Repair and clean contacts of connector.

3. Check voltage regulator/rectifier.
 - Refer to charging system.
4. Check wiring harness for cracks or other damages.
 - harness shows electrical failure and/or other damages. Replace/repair wiring harness.

LUBRICATION

Symptom: LOW OR NO OIL PRESSURE/HIGH OIL CONSUMPTION

1. Check oil level and search for leakage on crankcase and/or sealing parts.
 - Crankcase is leaking due to damage. Rebuild engine with new crankcase and gasket parts. Use recommended oil (refer to technical specifications).
 - Crankcase is leaking due to loose screws. Retighten screws with recommended torque
 - Sealing rings, O-rings and/or gaskets are brittle, hard or damaged. Replace damaged parts.
 - Piston rings worn out (blue colored engine exhaust emission). Replace piston rings (refer to cylinder and head).
 - Piston rings are broken (low compression). Replace piston rings (refer to cylinder and head).
 - Valve stem seal damaged and/or sealing lip is hard and/or brittle. Replace all valve stem seals.
2. Check oil filter for contamination.
 - Oil filter clogged. Replace oil and oil filter at the same time. Use recommended oil (refer to technical specifications).
3. Check oil drain plug on engine bottom.
 - Plug is loose and/or gasket ring is missing. Retighten the plug and/or place gasket ring.
4. Check leak indicator hole if oil leaks (in crankcase MAG side-water pump housing area).
 - Oil leaking from leak indicator hole means a damaged oil seal on water pump shaft. Replace oil seal (refer to cooling system).
5. Check oil pressure switch function.
 - Oil pressure switch damaged. Replace oil pressure switch.
6. Check oil orifice(s) on the oil pump suction side.
 - Oil orifice(s) is (are) clogged. Clean from contamination. Replace oil and oil filter if necessary (refer to maintenance or lubrication system).
7. Check oil pump function.
 - Oil pump rotor is out of wear limit. Replace oil pump (refer to lubrication system).
 - Oil pump seized due to oil leakage and/or air inclusion. Replace oil pump (refer to lubrication system).
 - Gears driving oil pump are broken or otherwise damaged. Replace gears.
 - Incorrect oil being used. Use recommended oil (refer to technical specifications).

8. Check oil pressure regulator valve (spring) function.
 - Valve spring damaged (valve always open). Replace spring.
 - Valve piston is worn or broken. Replace valve piston (refer to lubrication system).
 - Valve piston stays open due to contamination. Clean or repair valve piston.
9. Check plain bearings in crankcase for heavy wear.
 - plain bearings out of specification (increased clearance). Replace plain bearings (refer to bottom end).
10. Check engine oil strainer in crankcase.
 - Oil strainer is clogged due to contamination. Clean or replace strainer and diagnose causes. Replace possible damaged parts (refer to bottom end).

Symptom: OIL CONTAMINATION (white appearance)

1. Check leak indicator hole (in crankcase MAG side-water pump housing area) if water and oil leaks.
 - Leakage of oil/water mixture from indicator bore means damaged water pump seal ring and rotary seal. Replace sealing ring, rotary seal and change oil, oil filter and/or coolant (refer to lubrication system, cooling system and bottom end).
2. Check cylinder head and/or cylinder base gasket..
 - Gasket damaged or leaking. Retighten cylinder head with recommended torque and/or replace gasket.
3. Check tightening torque of cylinder head screws.
 - Screws not properly tightened. Retighten screws to recommended torque and replace oil.
4. Check oil for particles (may indicate possible engine internal damages).
 - Oil contamination due to metal or plastic particles. Replace possibly damaged part(s) including oil and oil filter. Use recommended oil (refer to technical specifications).

CYLINDER AND HEAD

Symptom: UNUSUAL ENGINE NOISE AND/OR VIBRATION

1. Check noise coming from cylinder head area.
 - Improper valve clearance adjustment. Readjust valve clearance and/or replace defective part(s).
 - Faulty chain tensioner. Replace spring and/or mechanism.
 - Chain guide worn out. Replace chain guide.
 - Stretched chain and/or worn out sprockets. Replace chain and sprockets.
 - Sprocket screws got loose. Retighten screws with recommended torque.
 - Rocker arm(s) is (are) worn out (valve adjustment). Readjust valve clearance and/or replace rocker arm(s).
 - Incorrect camshaft timing adjustment. Replace damaged components and readjust camshaft timing (refer to cylinder and head).

Symptom: OIL CONTAMINATION ON CYLINDER AND/OR HEAD

1. Check screws for torque.
 - Loose screws. Retighten screws with recommended torque.
 - Gaskets are brittle, hard, worn out or otherwise damaged. Replace damaged gaskets, O-rings or the V-ring on breather.

CRANKSHAFT

Symptom: UNUSUAL ENGINE NOISE AND/OR VIBRATION

1. Check noise coming from crankshaft area..
 - Crankshaft plain bearings are damaged,. Replace crankshaft plain bearings.
 - Connecting rod plain bearings are damaged. Replace connecting rod plain bearings.
 - Magneto rotor got loose. Replace damaged components and retighten rotor retaining screw with recommended torque (refer to MAGNETO SYSTEM).

GEARBOX

Symptom: UNUSUAL GEARBOX NOISE AND/OR VIBRATION

1. Check oil level in gearbox.
 - Oil leakage from gearbox. Replace damaged gasket(s) and/or oil seal(s), torque screws and refill with oil up to specified level (refer to TECHNICAL SPECIFICATIONS and GEARBOX)
2. Check bearings in the gearbox for free movement.
 - Bearing(s) do(es) not move freely. Replace bearing(s)
3. Check for knocking noise.
 - Tooth of gears are damaged and/or worn. Replace respective gears.

Symptom: GEAR INDICATION FAILS.

1. Check contact screws on gear housing center.
 - Check contact screw outside for contamination and wetness. Clean contact screw and screw for wiring harness.
 - Contact(s) is (are) corroded and/or contact screw for wiring harness got loose. Clean contact surface and retighten contact screw(s) with recommended torque.
 - Wiring harness has broken cables. Replace wiring harness.
 - Shifting indicator switch(es) pin(s) is (are) worn and/or damaged. Replace shifting indicator switch(es).

Symptom: GEAR(S) IS (ARE) HARD TO SHIFT

1. Check shift shaft splines and/or shift forks for wear and/or damages.
 - Shift shaft is worn out and/or shows damaged splines. Replace shift shaft.
 - Shift drum track(s) and/or splines is (are) worn out or damaged. Replace shift drum and damaged part(s).
 - Shift fork(s) is (are) worn out and/or engagement pins are damaged. Replace shift fork(s).
 - Shift fork(s) is (are) worn out and/or fork(s) is (are) damaged. Replace shift fork(s).

- Shift gear(s) is (are) worn out. Replace shift gear(s).
 - Shifting indicator switch(es) pin(s) is (are) worn out (no rounding on top of pin). Replace shifting indicator switch(es).
2. Check spring on shift shaft in gearbox.
 - Broken spring. Replace the spring (refer to GEARBOX).

COUPLING UNIT

Symptom: 4 WHEEL DRIVE INDICATION FAILS

1. Check contact screw on gear housing right side for damage and/or wear.
 - Shifting indicator switch pin is worn and/or damaged. Replace shifting indicator switch.
 - Contact is corroded and/or contact screw for wiring harness got loose. Clean contact surface and retighten contact screw with recommended torque.
 - Wiring harness has broken cable. Replace wiring harness.

Symptom: 4 WHEEL DRIVE DOES NOT ENGAGE OR DISENGAGE

1. Check actuator wireharness are loose.
2. Remove the actuator cover, and check if actuator is stuck or over travel.
 - Eliminate the binding or return to normal position by hand.
3. Check actuator and/or actuator shifting fork for wear and/or damages.
 - Check if selector works properly. If so, check actuator.
 - If selector is out of specifications, check wires, connectors and/or replace selector.
 - Actuator shifting fork is worn out and/or damaged. Replace shifting fork of actuator.
 - Check function of actuator. Replace if actuator is not turning, refer to GEARBOX.
4. Check shifting sleeve splines and/or shifting fork for wear and/or damages.
 - Check sleeve shows damaged splines. Replace shifting sleeve (refer to GEARBOX).
 - Shifting fork is worn out and/or engagement pin is damaged. Replace shifting fork.

CVT

Symptom: UNUSUAL ACCELERATION BEHAVIOR

1. Check drive belt condition.
 - Belt is too narrow (drive belt engagement is higher in drive pulley).replace belt if width is less than specified.
2. Check lever condition on drive pulley sliding sheave and/or roller(s) on governor cup.
 - Lever(s) on drive pulley sliding sheave is (are) worn and/or damaged. Replace all levers at the same time (lever kit).
 - Roller(s) is (are) worn and/or damaged. Replace governor cup assembly.
3. Check drive/driven pulley sliding sheave for free axial movement.
 - Sliding sheave is stuck. Replace damaged part(s).

4. Check condition of drive/driven pulley spring.
 - Drive pulley spring tension is too smooth and/or damaged. replace spring.
 - Driven pulley spring tension is too stiff. Replace spring.
5. Check if cam of driven pulley is worn.
 - Replace if out of specifications.
6. Check condition of fixed and sliding sheaves (drive and driven pulley).
 - Check surface of fixed and sliding sheaves (drive and driven pulley) for grooves or other damages.
7. Check valve adjustment.
 - Intake and/or exhaust valves are not adjusted correctly. Adjust valves.
8. Check engine condition.
 - Low engine compression.
9. Check ignition condition.
 - Faulty spark plug. Install new spark plug(s).
10. Check differentials operation.
 - Vehicle on Neutral is hard to move. Repair or replace defective part(s).

Symptom: ENGINE MAXIMUM RPM IS TOO HIGH AND VEHICLE TOP SPEED IS NOT REACHED.

1. Check drive/driven pulley area for contamination and/or water intrusion.
 - CVT area is contaminated with water, dirt or oil. Clean CVT system and replace damaged part(s).
2. Check drive/driven pulley spring tension.
 - Drive pulley spring tension is too stiff. Replace spring.
 - Driven pulley spring tension is too smooth and/or damaged. Replace spring.

Symptom: DRIVE PULLEY NOISE IN IDLE SPEED

1. Check slider shoes (drive pulley).
 - Worn slider shoes (increased clearance between governor cup and drive pulley sliding sheave). Replace all slider shoes at the same time (slider shoes kit).
2. Check driven pulley sliding mechanism (between driven pulley outer and inner sheave).
 - Mechanism is stuck and/or damaged. Replace driven pulley assembly.
5. Check roller(s) and/or levers for wear (located on sliding sheave of drive pulley).
 - Roller(s) on governor cup is (are) worn out and/or damaged. Replace governor cup assembly.
 - Lever(s) on drive pulley sliding sheave is (are) worn out and/or damaged. Replace all levers at the same time (lever kit).
6. Check drive pulley screw for torque.
 - Loose screw. Retighten screw with recommended torque.
7. Check one-way clutch condition on drive pulley sliding sheave (if have) .
 - Bearing(s) do(es) not move freely. Replace damaged part(s) and lubricate inside of one-way clutch.
 - Spring sleeve(s) inside one-way clutch is (are) worn out. Replace both sleeves and springs and lubricate inside of one-way clutch.

- Spring(s) inside one-way clutch is (are) worn out. Replace both pins and springs and lubricate inside of one-way clutch.

Symptom: DRIVE PULLEY NOISE WHEN ACCELERATING/DECELERATING

1. Check if belt runs in dry condition.
 - Drive pulley area is wet/contaminated due to water/dirt intrusion. Clean driven pulley area and/or drain water out of CVT cover.
2. Check drive/driven pulley screw for torque.
 - Loose screw on drive pulley. Retighten screw with recommended torque.
3. Check cam and driven pulley fixed sheave for wear.
 - Cam and/or drive pulley fixed sheave out of wear limit and/or damaged. Replace damaged part(s).
4. Check torque gear fixed in driven pulley sliding sheave for wear.
 - Torque gear out of wear limit and/or damaged. Replace torque gear).
5. Check for foreign particles in CVT area (stones, dirt, etc.).
 - Small particles damaged belt and/or pulley surface(s). clean system and replace damaged parts.

Symptom: VIBRATIONS ORIGINATING FROM DRIVE PULLEY

1. Check tightening torque of drive pulley screw.
 - Moving sliding sheave. Retighten screw.
2. Check fixed sheave bushings.
 - Excessive gap between bushings and fixed sheave shaft, thus restraining sliding sheave movements. Replace fixed sheave assembly.
3. Check if slider shoes are present and/or placed in correct position.
 - Slider shoe(s) is (are) missing and/or damaged. Replace all slider shoes at the same time (slider shoes kit).

Symptom: VIBRATIONS ORIGINATING FROM DRIVEN PULLEY

1. Check fixed and sliding sheave bushings on driven pulley.
 - Excessive gap between bushings and CVT shaft, thus restraining sliding sheave movements. Replace fixed and/or sliding sheave of driven pulley, polish CVT shaft area with fine emery cloth and wipe clean with a cloth.

Symptom: PULLEYS DO NOT DOWN/UP SHIFT PROPERLY.

1. Check drive pulley bushings (cleanliness, wear, etc.)
 - Check items 1 and 2 of UNUSUAL ACCELERATION BEHAVIOR.
 - Bushings stick to fixed sheave pulley shaft. Clean or replace.
 - Spring seat sticks to sliding sheave pulley bushing. Clean system and/or replace sliding sheave pulley.
 - One-way clutch(if have) does not operate properly. Clean system and/or replace damaged part(s).
2. Check driven pulley spring tension.
 - Driven pulley spring tension is too weak or broken. Replace.
 - Driven pulley cam is worn or damaged. Replace.

Symptom: BELT GLAZED EXCESSIVELY OR HAVING BAKED APPEARANCE

1. Check if CVT air intake and/or outlet is clogged.
 - CVT area heats up due to contamination. Clean air intake and/or outlet

from contamination.

- Fans located on drive pulley is worn or damaged. Replace.
2. Check if pulley sheaves are clean.
 - Oil on pulley surfaces. Clean pulley sheaves and replace belt.
 - Water intrusion in CVT area. Find root cause and repair. Drain water and replace belt.

Symptom: BELT WORN EXCESSIVELY IN TOP WIDTH.

1. Check drive belt width.
 - Considerable wear. Replace belt if narrower than specified (refer to CONTINUOUSLY VARIABLE TRANSMISSION (CVT) OR TECHNICAL SPECIFICATIONS).
2. Check driver belt identification number.
 - Wrong type of belt. Replace belt with an appropriate drive belt.
3. Check for localized belt wear caused by belt slippage.
 - Localized wear. Replace belt.

Symptom: BELT DISINTEGRATION.

1. Check drive belt lifetime is exceeded..
 - Clean CVT system and rebuild with a new drive belt.
2. Check drive belt identification number.
 - Excessive belt speed. Using unspecified type of belt. Replace belt with proper type of belt.
3. Check if pulley sheaves are clean.
 - Oil on pulley surfaces. Clean pulley surfaces with fine emery cloth and wipe clean using pulley flange cleaner and a cloth.
 - Drive/driven pulley sheaves are damaged through stones inside CVT area. Clean pulley surfaces with fine emery cloth, wipe clean with a cloth or replace drive/driven pulley sheaves and belt.

Symptom: BACK BETWEEN COGS

1. Check drive belt condition.
 - Considerable use, belt wearing out. Replace.
 - Brittle belt condition through aging. Replace belt.

ENGINE GENERAL

Symptom: ENGINE CRANKS BUT FAIL TO START

1. Check fuel level in fuel tank and fuel pressure. Ensure fuel pump was not disabled.
 - Whether can hear the voice the fuel pump running
 - Low or no fuel pressure. Replace defective part(s)
2. Check battery voltage.
 - Battery is discharged and starter works not properly. Charge battery
3. Check fault codes in DELPHI EFI system.
 - Check if electrical actuator(s) is/are defective. Replace defective part(s) (refer to COMPONENT INSPECTION AND ADJUSTMENT)

4. Check if spark plug connectors fit on spark plugs (refer to IGNITION SYSTEM).
5. Check spark plugs.
 - Define spark plugs (no spark) or wrong spark plug gap. Readjust gap and clean spark plugs or replace.
6. Check for fuel on spark plugs.
 - Flooded engine (spark plugs wet when removed). Activate engine drowned mode and crank engine with rags over the spark plug holes.
7. Check fuel injectors.
 - Plugged or faulty injector(s). Replace defective part(s).
8. Check idle bypass valve.
 - Stuck or defective..
9. Check encoder wheel.
 - Bent tooth. Refer to MAGNETO SYSTEM.
10. Check engine compression.
 - Insufficient engine compression. Replace defective part(s).

Symptom: ENGINE DOES NOT START

1. Electrical problem.
 - Determine if the electrical system works correctly (fuse(s), battery, wiring harness, etc.). refer to IGNITION SYSTEM.
2. Problem with fuel system (carburetor, fuel pump, hoses, etc.).
 - Clean, inspect, repair or replace defective parts. Replace defective part(s).
3. Check engine compression.
 - Insufficient engine compression. Replace defective parts.
 - Valve seat worn and/or damaged. Repair by performing valve guide procedure (refer to CYLINDER AND HEAD). Readjust valve clearance.
4. Internal engine problem.
 - Overhaul engine to find defective parts. Refer to the appropriate section in ENGINE.

Symptom: ENGINE HARD TO START

1. Check idle bypass valve.
 - Stuck or defective. Refer to ENGINE MANAGEMENT.
2. Check closed throttle and idle actuator with DELPHI.
 - Wrong TPS zero setting/idle bypass valve reset. Refer to ENGINE MANAGEMENT.
3. Check engine compression.
 - Wrong adjustment (likely too tight). Refer to ENGINE MANAGEMENT.
4. Check engine compression.
 - Insufficient engine compression. Replace defective part(s) refer to LEAK TEST.
5. Verify spark plug condition.
 - Defective, improperly set, worn out, fouled. Identify source of problem and correct. Replace.

6. Check fuel level in fuel tank and fuel pressure.
 - Low or no fuel pressure. Replace defective part(s) refer to FUEL TANK AND FUEL PUMP.
7. Check CAPS (camshaft position sensor).
 - Defective sensor/wiring. Refer to ENGINE MANAGEMENT.

Symptom: ENGINE SUDDENLY TURNS OFF

1. Perform engine leak test.
 - Damaged head gasket and/or seal and/or leaking inlet/exhaust valve(s). replace and/or repair defective parts.
2. Check spark plugs condition and/or gap.
 - Fouled spark plugs or wrong spark plug gap. Readjust gap and clean spark plugs or replace..
3. Piston seizure.
 - Spark plugs heat range is too hot. Install spark plugs with appropriate heat range (refer to TECHNICAL SPECIFICATIONS).
 - Compression ratio is too high. Install genuine parts.
 - Poor oil quality. Use recommended oil.
 - Leaks at air intake manifold (engine gets too lean). Retighten screws or replace air intake manifold gasket.
 - Snow/water intrusion through intake system into combustion chamber. Clean intake system and replace defective part(s).
4. Melted and/or perforated piston dome; melted section at ring end gap.
 - Spark plugs heat range is too hot. Install recommended spark plugs (refer to TECHNICAL SPECIFICATIONS).
 - Coolant less than recommended level (engine gets too hot). Repair cooling circuit and/or refill with recommended liquid.
 - Poor quality and/or wrong fuel. Clean from contamination and use appropriate fuel (refer to TECHNICAL SPECIFICATIONS).
5. Piston color is dark due to seizure on intake and exhaust side.
 - Cooling system leaks and lowers coolant level. Tighten clamps or replace defective parts. Add antifreeze in cooling system until appropriate level s reached. Replace damaged parts.
6. Cracked or broken piston.
 - Cracked or broken piston due to excessive piston/cylinder clearance or engine overheating. Replace piston. Check piston/cylinder clearance (refer to CYLINDER AND HEAD).
7. Check piston rings and cylinder surface for grooves.
 - Poor oil quality. Use recommended oil.
 - Contamination through engine intake. Replace defective part(s) and use new air filter.
8. Check crankshaft, rocker arms movement.
 - Oil pump failure due to lack of oil. Repair and replace defective parts and use new recommended oil.
 - Oil contamination due to clogged oil filter/oil strainer. Replace oil and oil

filter at the same time, replace defective part(s).

9. Check valve springs exhaust/intake.
 - Broken valve spring damages the cylinder head, valve(s), rocker arm(s), piston, piston rings and connecting rod. Replace defective part(s).
10. Check if fuel supply is sufficient.
 - Low fuel level.
 - Clogged fuel filter or fuel injector filter.
 - Fuel line is contaminated and/or bent. Clean and/or replace defective part(s).

Symptom: ENGINE BACKFIRES

1. Check spark plugs.
 - Carbon accumulation caused by defective spark plugs. Replace spark plugs.
2. Check leakage on intake manifold.
 - Air leak on intake system. Retighten screws and/or replace intake manifold gasket.
3. Check exhaust air leaking.
 - Exhaust gasket is leaking. Retighten screws and/or replace exhaust gasket.
4. Check intake valve(s) for leaking.
 - Intake valve(s) is (are) leaking. Repair or replace valve(s).
5. Check if fuel supply is sufficient.
 - Fuel line is contaminated and/or bent (engine gets lean). Clean and/or replace defective part(s).
6. Check engine ground.
 - Poor engine ground. Clean.

Symptom: ENGINE DOES NOT OFFER MAXIMUM POWER AND/OR DOES NOT REACH MAXIMUM OPERATING RPM

1. Check spark plugs condition and/or gap.
 - Fouled spark plugs or wrong spark plug gap. Readjust gap and clean spark plugs or replace.
2. Check spark plugs type.
 - Improper spark plugs heat range. Install recommended spark plugs (refer to TECHNICAL SPECIFICATIONS).
3. Perform engine leak test.
 - Damaged head gasket and/or seal and/or leaking intake/exhaust valve(s). replace and/or repair defective parts.
4. Check for water in fuel (wrong fuel).
 - There is water in fuel or wrong fuel. Drain fuel system, search for leakage and refill it with appropriate fuel.
5. Check engine compression.
 - Worn piston(s) and/or piston ring(s). Replace defective part(s).+
6. Check fuel pressure.
 - Low fuel pressure. Perform fuel pressure test (refer to FUEL SYSTEM).

7. Check air intake system.
 - Air filter is clogged due to contamination. Replace air filter.
8. Check if EMS (engine management system) is in limp home mode. Check fault codes in DELPHI EFI system.
 - Check if electrical actuator(s) is/are defective. Replace defective part(s).
9. Check drive belt.
 - Worn. Replace belt if its width is less than specified.

Symptom: HIGH ENGINE OPERATING TEMPERATURE

1. Check if cooling system shows any failure (see COOLING SYSTEM).
 - System is leaking. Repair and/or replace damaged part(s).
2. Check function of lubrication system (see LUBRICATION SYSTEM).
 - Lubrication is not working properly. Repair and/or replace damaged part(s).
3. Check condition and heat range of spark plugs.
 - Melted spark plug tip or inadequate heat range. Replace.
4. Check air leakage on engine intake.
 - Leakage causes overheating. Replace/repair damaged part(s).
5. Check air inlet and outlet of the CVT cover.
 - Air circulation is clogged (overheating). Clean air circulation from contamination.
 - Drive belt worn and/or damaged. Replace belt with an appropriate drive belt (refer to TECHNICAL SPECIFICATIONS).

FAULT CODES

A fault code is an indication that a glitch or malfunction is detected by the self-diagnostic system.

Read fault code

Lift the front hood and look for the WHITE harness connector of fault diagnosis tester behind the battery box.

Unplug the protector, connect the fault diagnosis tester by special data cable. Turn on the key power switch, select the operation menu on the diagnosis tester and read fault code.

CODE	FAULT
P0031	Cylinder 1 heater of oxygen sensor is existing short circuit to ground
P0032	Cylinder 1 heater of oxygen sensor is existing short circuit to power supply
P0037	Cylinder 2 heater of oxygen sensor is existing short circuit to ground
P0038	Cylinder 2 heater of oxygen sensor is existing short circuit to power supply
P0107	Intake manifold pressure sensor is existing short circuit to ground or
P0108	Intake manifold pressure sensor is existing short circuit power supply
P0112	Intake air temperature sensor is existing short circuit to ground or disconnecting
P0113	Intake air temperature sensor is existing short circuit power supply
P0117	Coolant temperature sensor is existing short circuit to ground
P0118	Coolant temperature sensor is existing short circuit to power supply or
P0122	Throttle position sensor is existing short circuit to ground or disconnecting
P0123	Throttle position sensor is existing short circuit to power supply
P0131	Cylinder 1 oxygen sensor is existing short circuit to ground
P0132	Cylinder 1 oxygen sensor is existing short circuit to power supply

P0137	Cylinder 2 oxygen sensor is existing short circuit to ground
P0138	Cylinder 2 oxygen sensor is existing short circuit to power supply
P0201	Injector of cylinder 1 is damaged
P0202	Injector of cylinder 2 is damaged
P0230	Fuel pump is existing short circuit to ground or disconnecting
P0232	Fuel pump is existing short circuit power supply
P0336	Signal of crankshaft position sensor is disturbed
P0337	No signal of crankshaft position sensor
P0351	Ignition coil of cylinder 1 is damaged
P0352	Ignition coil of cylinder 2 is damaged
P0505	Air bypass valve is damaged
P0562	Power supply voltage is too poor
P0563	Power supply voltage is too high
P0650	Engine indicator lamp is damaged
P1693	Signal of speed gauge is existing short circuit to ground
P1694	Signal of speed gauge is existing short circuit to power supply

Clear fault code

After correcting the problem that caused the fault code, there two ways to clear fault code:

- 5) By the fault diagnosis tester.
- 6) Put the key power switch at the OFF position for at least 30 seconds, then switch the key (OFF -- ON) for 5 times within 3 seconds quickly and continuously, and then wait at least 30 seconds for the last time at the OFF position. Turn on the key power switch, if the failure light is not ON means the operation is successfu.